

(12) STANDARD PATENT APPLICATION (11) Application No. AU 2024216404 A1
(19) AUSTRALIAN PATENT OFFICE

(54) Title
RACKING SUPPORT

(51) International Patent Classification(s)
B65D 19/00 (2006.01)

(21) Application No: **2024216404** (22) Date of Filing: **2024.08.28**

(43) Publication Date: **2026.03.19**

(43) Publication Journal Date: **2026.03.19**

(71) Applicant(s)
Containit Pty Ltd

(72) Inventor(s)
Mansley, Stephen Philip; Mansley, Daniel Stephen; Mansley, Chester Roland; Taylor, Keiran James; Esho, Andy Assur; Frost, Jake Elliott

(74) Agent / Attorney
Franke Hyland Pty Ltd, PO Box 356, NORTH RYDE BC, NSW, 1670, AU

28 Aug 2024

2024216404

Abstract

The invention provides a support platform for an IBC that includes a frame for receiving the base of an IBC, and recesses on the base of the frame, adapted to receive the support members of a location in a pallet rack.

RACKING SUPPORT

Technical Field

[0001] The present invention relates to storage containers, such as IBCs (intermediate bulk containers) and facilitating their storage.

Background of the Invention

[0002] IBCs are widely used to store and transport materials such as water, liquids, oils, powders, granules and related materials. IBCs provide a standard sized storage and transport container, which has proved efficient and reliable, and hence millions are in use internationally.

[0003] IBCs come in a variety of forms, the most common of which is the limited re-use, caged IBC tote container. These are typically formed from a white or translucent plastic container, typically HDPE, within a tubular galvanised steel grid cage. The base of an IBC is formed from steel in the form of a rectangular pallet type base, typically, 1200 mm × 1000 mm, with slots to permit handling by forklift equipment.

[0004] For many warehouses and similar storage facilities, it is common to use pallet racks to store pallets. Pallet racking generally consists of a support structure, with two metal sections providing support for each wooden pallet which is placed upon the supports. Typical vertical spacings between the racks are 1200 mm, so that many pallets may be placed vertically above each other. This is a cost effective storage system for wooden pallets. Long bays of double sided pallet racking may be provided in a warehouse, for example.

[0005] However, for IBCs, several issues arise. First, the engagement of the metal base with metal rack supports offers much less friction than between wooden pallets and the metal supports. Further, a filled IBC has a relatively high centre of gravity. In combination, this makes the IBC relatively insecure on pallet racking, and prone to be dislodged by an impact from a forklift, for example when accessing a neighbouring storage position. This creates a safety risk for the storage facility operator, and for the workers in that facility.

[0006] It is an object of the present invention to provide a device to improve the safety of storing IBCs, and similar storage containers, on pallet racking.

Summary of the Invention

[0007] According to one broad aspect of the invention, there is provided a support platform for an IBC, including a frame for receiving the base of an IBC, and recesses in the lower surface of the frame, adapted to receive the support members of a location in a pallet rack.

[0008] According to another aspect, the present invention provides a support platform for an IBC, operatively adapted to support an IBC on a pallet rack, the support platform including a frame for receiving a base of an IBC, and recesses on the lower surface of the frame operatively adapted to receive support members of a pallet rack.

[0009] Implementations of the present invention are able to provide a support platform that enables safe lifting and storage of four-way access IBCs on both pallet racking and on flat, level ground, particularly in warehouse environments.

Brief Description of the Drawings

[0010] Illustrative implementations of the present invention will be described with reference to the accompanying figures, in which:

[0011] Figure 1 is a perspective view of a first implementation of a support platform for an IBC according to the present invention;

[0012] Figure 2 is a perspective view of the support platform of Figure 1 with the IBC;

[0013] Figure 3 is a perspective view of tubular elements;

[0014] Figure 4 is a bottom perspective view of the tubular elements;

[0015] Figure 5 is a top perspective view of the tubular elements with transverse elements;

[0016] Figure 6 is a bottom perspective view of the tubular elements with transverse elements;

[0017] Figure 7 is a top perspective view of support platform of Figure 1;

[0018] Figure 8 shows the IBC being forklifted on the support platform of Figure 1;

[0019] Figure 9 shows the support platform of Figure 1 and the IBC fully engaged;

[0020] Figure 10 shows the location of the forklift tynes when forklifting the support platform and the IBC;

[0021] Figure 11 shows the fully engaged support platform of Figure 1 and the IBC in a pallet racking;

[0022] Figure 12 is a perspective view of a second implementation of a support platform for the IBC according to the present invention;

[0023] Figure 13 shows the fully engaged support platform of Figure 12 and the IBC with strap;

[0024] Figure 14 shows pallet racking location elements of the support platform of Figure 12;

[0025] Figure 15 shows forklift tyne location loops of the support platform of Figure 12;

[0026] Figure 16 shows the IBC being forklifted on the support platform of Figure 12;

[0027] Figure 17 shows the location of the forklift tynes when forklifting the fully engaged support platform of Figure 12 and the IBC.

[0028] Figure 18 shows the fully engaged support platform of Figure 12 and the IBC in a pallet racking;

[0029] Figure 19 shows the location of the forklift tynes when forklifting the support platform of Figure 12; and

[0030] Figure 20 shows support platforms of Figure 12 stack on top of each other in a pallet racking.

Detailed Description of the invention

[0031] The present invention will be described with reference to implementations and examples using specific structures and materials. It will be understood that alternative materials may be used, alternative or additional structures may be included, within the

general scope of the present invention. The examples provided should be interpreted as illustrative and not limitative of the scope of the present invention.

[0032] Steel-framed IBCs (10) are normally carried via forklift, with the tines passing through the lower portion of the IBC frame and supporting the IBC (10) underneath the base. These IBCs (10) are 4-way forklift accessible, i.e. they can be forklifted from the front, back or either side. The term IBC is intended to encompass IBCs and any similar structures that may now in future be developed with similar characteristics, particularly those with a metal base structure.

[0033] As shown in Figure 2, the structural intent of the support platform (100,200) of the present invention is to support the IBC (10) directly underneath the base. This approach takes advantage of the 4-way access of IBCs (10), and ensures that variability in the dimensions of the lower portion of the IBC frame can be accounted for.

[0034] Figure 1 illustrates a first implementation of a support platform (100) of the present invention. The support platform (100) has two tubular elements (110) and external perimeter structures (130) on each side of the support platform (100). The core of the support platform (100) of the present invention is the two tubular elements (110). As shown in Figures 3 and 4, the tubular elements (110) feature cutouts that allow the IBC (10) to be forklifted both onto and off the support platform (100), and cutouts that allow the support platform (100) to be located onto pallet racking. The forklift tynes pass through the two tubes (110) when lifting the support platform (100) and IBC (10) together. The floor of the IBC (10) rests on the top faces of these tubes (110) when placed on the support platform (10). They transfer this load to the floor, or to pallet racking beams underneath.

[0035] These tubes (110) may be constructed from steel, plastics or composites of suitable strength and durability. The support platform (100) is preferably constructed from steel tubes of wall thickness 9 mm, and fabricated steel perimeter elements (130) of wall thickness 4 mm. The assembly is then zinc plated for corrosion resistance. However, these materials could be other metals, plastics, or composites of suitable thickness for the material properties and load.

[0036] As shown in Figures 5 and 6, the tubular elements (110) are constrained together with transverse elements (120) – in particular, with two running through the pallet racking location cutouts at each end of the tube (110). These transverse elements (120) prevent damage to pallet racking means when the unit is placed on pallet racking.

[0037] Figure 7 shows the external perimeter structures (130) of the support platform (100). This is not intended to bear the load of the IBC (10) in the manner of the

aforementioned tubular elements (110). Instead, it allows the individual support platform (100) to stack for freight and storage; visually aids the forklift operator to guide the IBC (10) onto the support platform (100) laterally; provides lateral location for the IBC (10) to nest down into the support platform (100), so that in this implementation the IBC (10) does not to be strapped down to the support platform (100). The external perimeter structures (130) include cutouts on the side elements so the forklift operator can see where the pallet racking beams should line up when lowering on to pallet racking. However, these cutouts include sufficient clearance to ensure they are not load bearing when the unit is stored on pallet racking.

[0038] As shown in Figure 8, in operation, the IBC (10) is forklifted from the side for lowering on/off the support platform (100). The cutouts in the tubular elements (110) provide clearance for the forklift tynes.

[0039] As shown in Figure 9, the IBC floor is supported by the tubular elements (110). There is a clearance so that the lower frame tubes of the IBC (10) will never touch the perimeter elements of the support platform (100) and cause them to bear the load. This is desirable, since variability in the height of the lower portion of the IBC frame would otherwise cause a one-or-the-other scenario in terms of load bearing.

[0040] As can be seen in Figure 10, the IBC (10) and support platform (100) can be forklifted together through tubes (110) via the front or back for placement on pallet racking. This ensures that the load of the IBC (10) is transferred directly to the forklift tynes when lifting.

[0041] As shown in Figure 11, the IBC (10) and support platform (100) can then be lifted together onto the pallet racking. Dismounting of the IBC (10) and support platform (100) from the racking, and dismounting of the IBC (10) from the support platform (100), is a reversal of the aforementioned steps. A key advantage is that the forklift operator does not need to leave forklift at any time to complete these steps.

[0042] Figure 12 illustrates a second implementation of a support platform (200) according to the present invention. As shown in Figures 12, 14 and 15, the support member (200) has four perimeter structures (230), side forklift tyne location windows (240), four forklift tyne location loops (210) and pallet racking location features (250). The support platform (200) is constructed from laser cut and folded elements, all 4 mm thick, with 3 mm continuous fillet welds joining all elements. This is then zinc plated for corrosion resistance. However, they do not necessarily have to be zinc plated steel of the specified thicknesses. They could be metallic, plastic, or composite, to a thickness suitable for the material properties and load. Powder coated load/instruction plates are then riveted to each side.

[0043] The four perimeter elements (230) (front/back, and each side) are not intended to primarily bear the load of the product when forklifted. Instead, they allow the individual support platforms (200) to stack for freight and storage; visually aid the forklift operator to guide the IBC (10) onto the support platform (200) laterally; allow visibility for the pallet racking location features; and provide forklift tyne location windows (240) for lifting the support platforms (200) (without IBCs) individually and stacked together.

[0044] As can be seen in Figure 15, the side forklift tyne location windows (240) are deliberately obscured by the corner features of IBCs (10), so that these forklift tyne windows (240) cannot be used for lifting the IBC (10) and support platform (200) together.

[0045] As shown in Figure 12, there are also four forklift tyne location loops (210) on each inside corner of the structure to prevent individual support platforms (200) from titling off the end of forklift tynes when the support platforms (200) are being lifted without IBCs (10).

[0046] As shown in Figure 16, in operation, the IBC (10) is forklifted from the front or back for lowering on/off the support platform (200). The cutouts in the front and back elements tubes provide clearance for the forklift tynes. As can be seen in Figures 13 and 17, the IBC (10) must be strapped to the support platform (200) using a suitable ratchet strap (220) or similar. This constrains the IBC (10) and the support platform (200) together. The side elements of the support platform (200) include location features to facilitate this.

[0047] The IBC (10) and the support platform (200) together can then be forklifted through the front/back of the IBC (10). While being lifted, the support platform (200) is not bearing the load of the IBC (10). The strap (220) keeps the IBC (10) and support platform (200) constrained together. The support platform (200) can then be lowered and located onto pallet racking beams as shown in Figure 18. The transverse pallet racking location elements (250) in the support platform (200) transfer the load of the IBC (10) directly from the IBC frame to the pallet racking beams.

[0048] As shown in Figure 19, individual support platforms (200) can be lifted through the forklift tyne windows (240) in the side elements of the support platform (200), and the forklift tyne loops (210) in the structure. As shown in Figure 20, pallet racking location features (250) are located in the front and back of the structure to allow individual support platforms (200) and stacks thereof to be placed on pallet racking.

[0049] The idea of a pallet/support platform (100,200) allowing for use of pallet racking with IBCs (10) by providing recesses on the base for the pallet rack arms seems on the face new and patentable. The additional feature where forklift access from two

opposing sides allows the IBC (10) to be lifted in or out of the pallet/support platform (100,200), and from the other two sides lifts the pallet (100,200) and the IBC (10), adds another protectable aspect.

[0050] It will be appreciated by those skilled in the art that the above are merely examples of how the invention may be put into practice. There are many other physical configurations possible, which while in some details, would nevertheless fall within the spirit and scope of the invention.

CLAIMS

1. A support platform for an IBC, operatively adapted to support an IBC on a pallet rack, the support platform including a frame for receiving a base of an IBC, and recesses on the lower surface of the frame operatively adapted to receive support members of a pallet rack.
2. A support platform according to claim 1, wherein the frame includes perimeter structures for locating an IBC on the frame.
3. A support platform according to claim 1 or claim 2, wherein the frame includes at least two tubular elements, the tubular elements including the recesses on their lower surface.
4. A support platform according to any one of the preceding claims, wherein the tubular elements adapted to facilitate transfer of a load of the IBC to the pallet rack.
5. A support platform according to any one of the preceding claims, wherein the tubular elements are connected together with at least one transverse element.
6. A support platform according to any one of the preceding claims, wherein the perimeter structure has a first and second pair of opposing sides, and wherein a forklift may access through a first pair of opposing sides to place an IBC on the platform or remove it from the platform, and a forklift may access from a second pair of opposing sides to lift the platform together with the IBC to and from a storage location.
7. A support platform according to claim 1, wherein the support platform is adapted to receive an IBC, and the load of the IBC is operatively received directly onto the pallet rack, and wherein operatively a restraint is required to retain the IBC and the support platform together.
8. A support platform according to claim 1, wherein the support platform further including windows and loops to facilitate lifting and racking of individual support platform in the pallet rack.
9. A support platform according to claim 7, wherein the support platform has a first and second pair of opposing sides, and wherein a forklift may access through a first pair of opposing sides to place an IBC on the platform or remove it from the platform, and when an IBC has been placed on the platform, structures prevent

the forklift from engaging the support platform from the second pair of opposing sides.

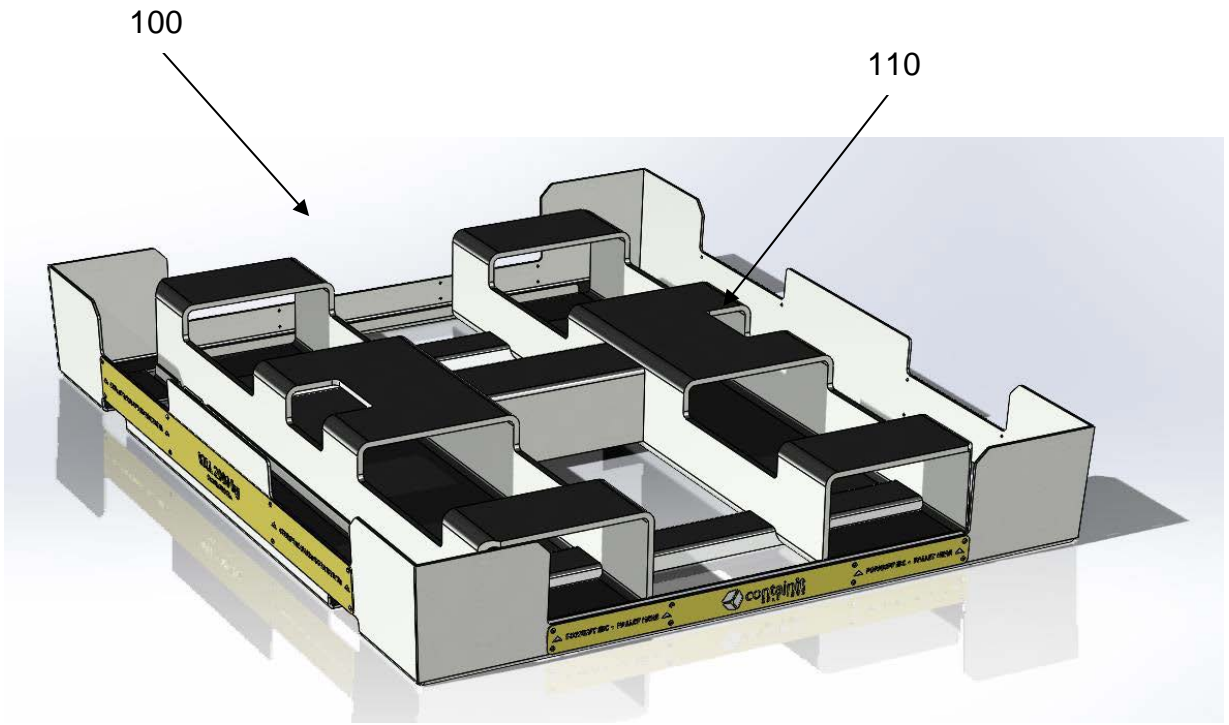

Figure 1



Figure 2

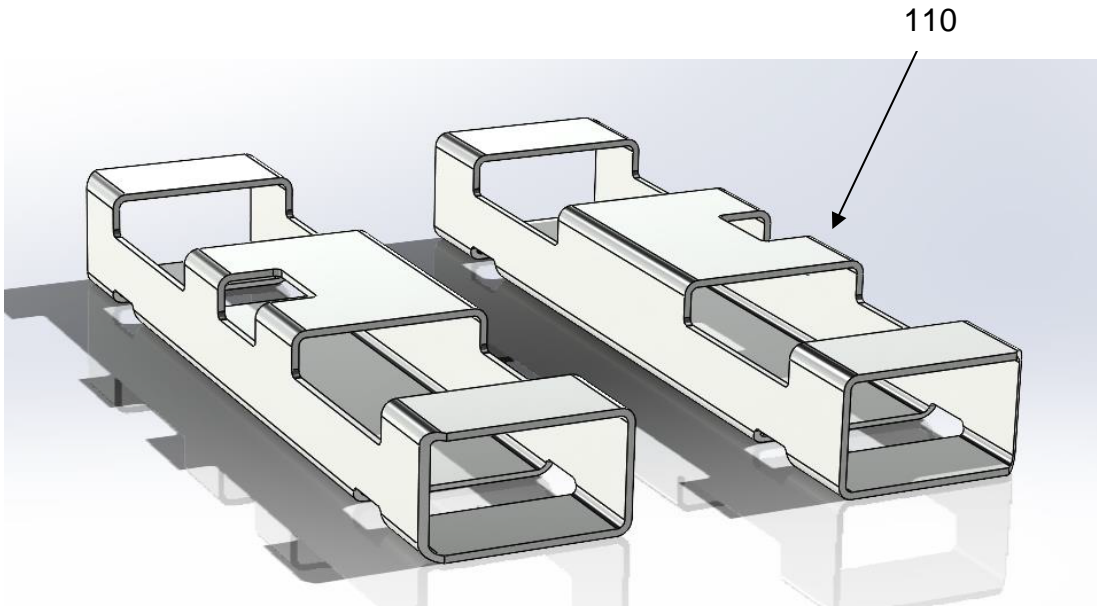

Figure 3

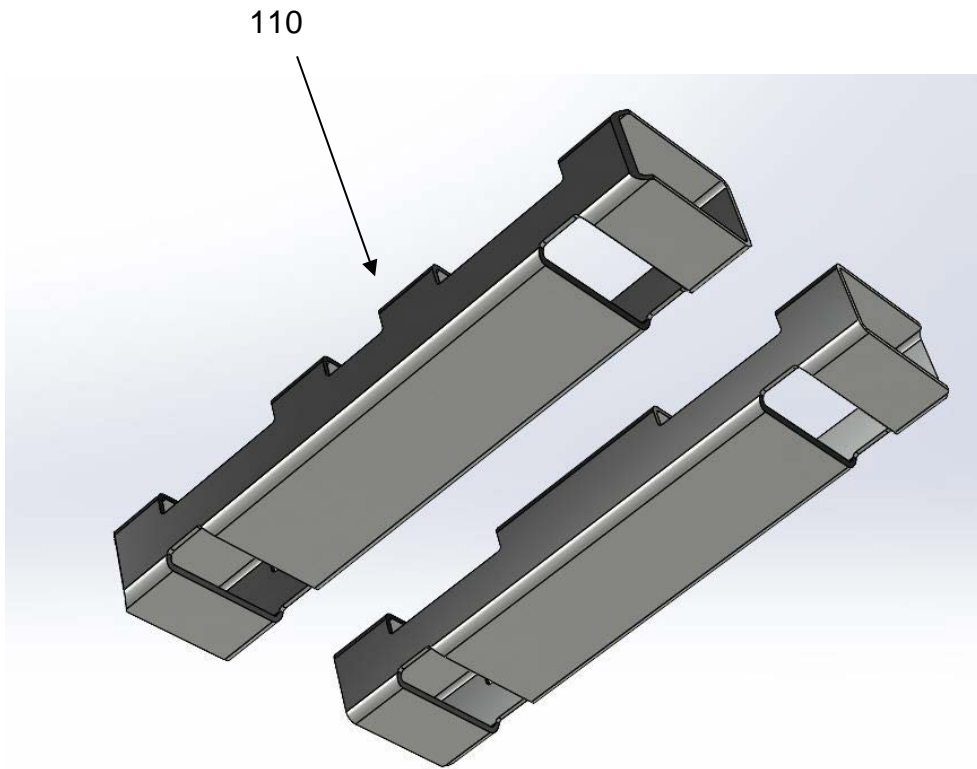

Figure 4

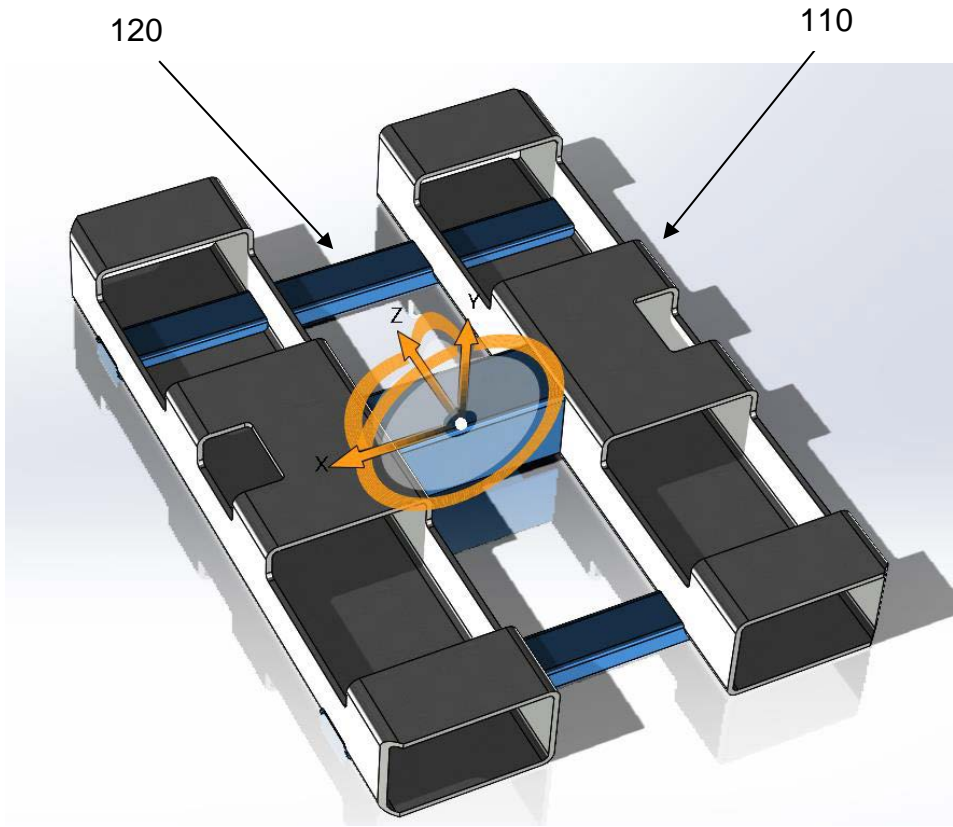

Figure 5

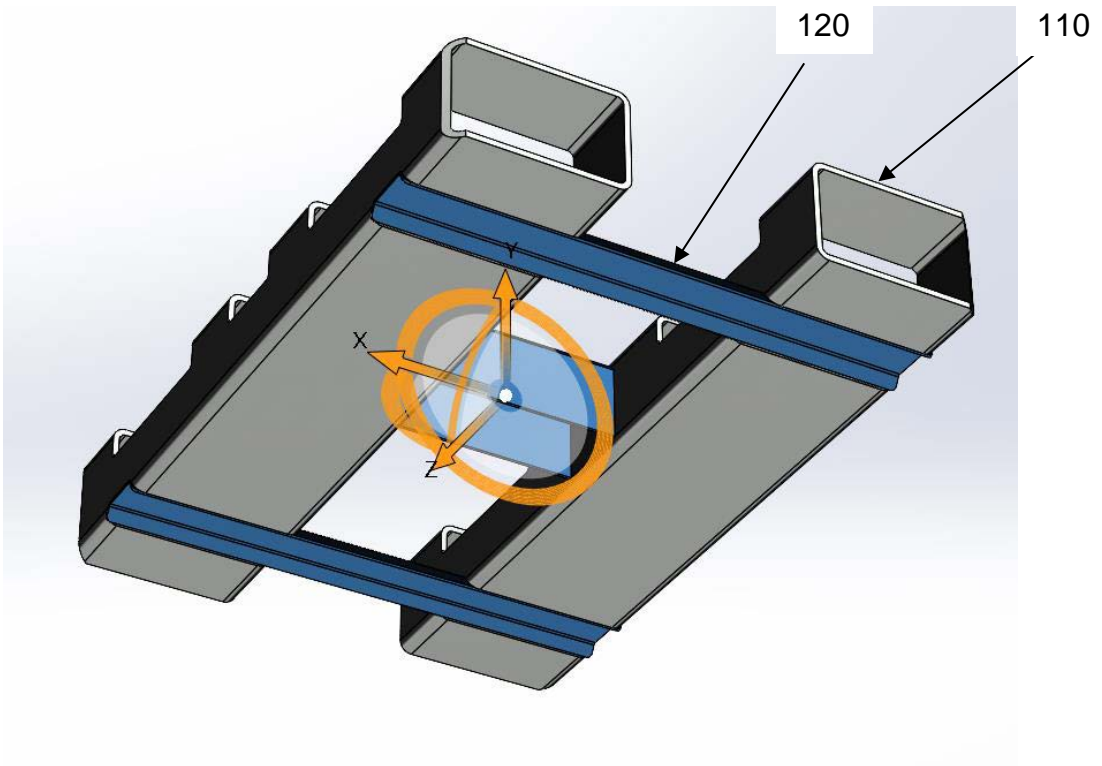

Figure 6

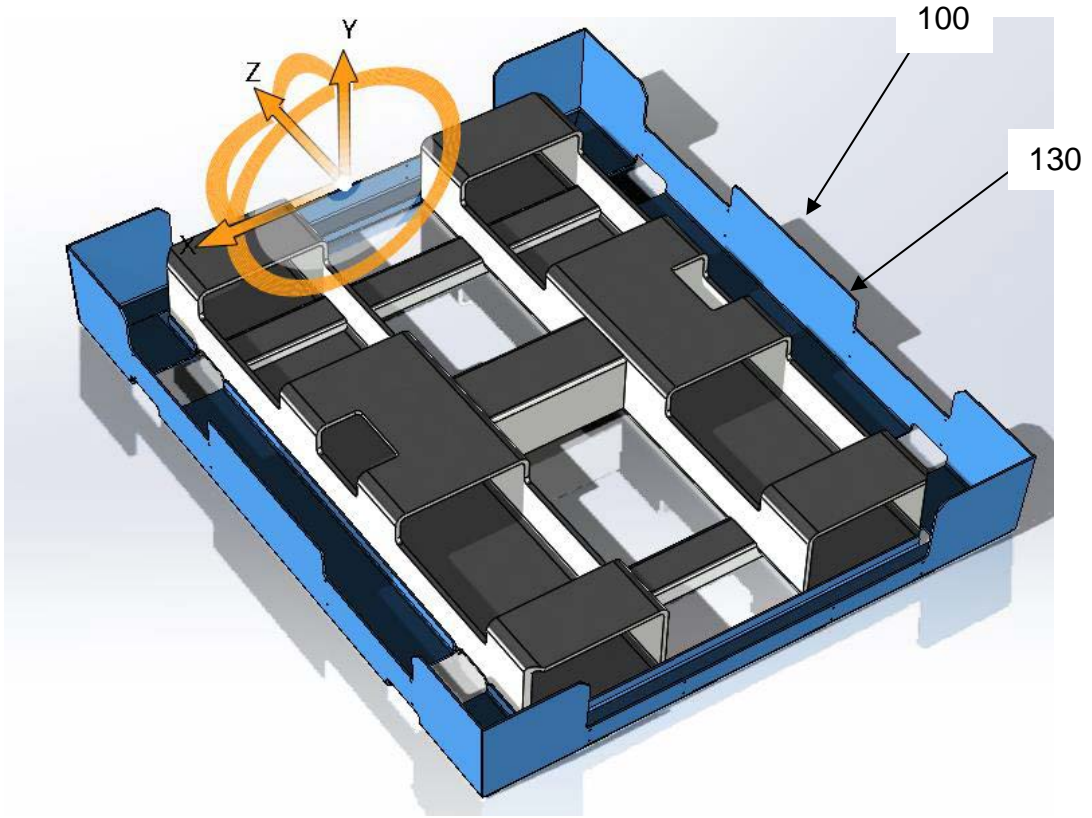

Figure 7

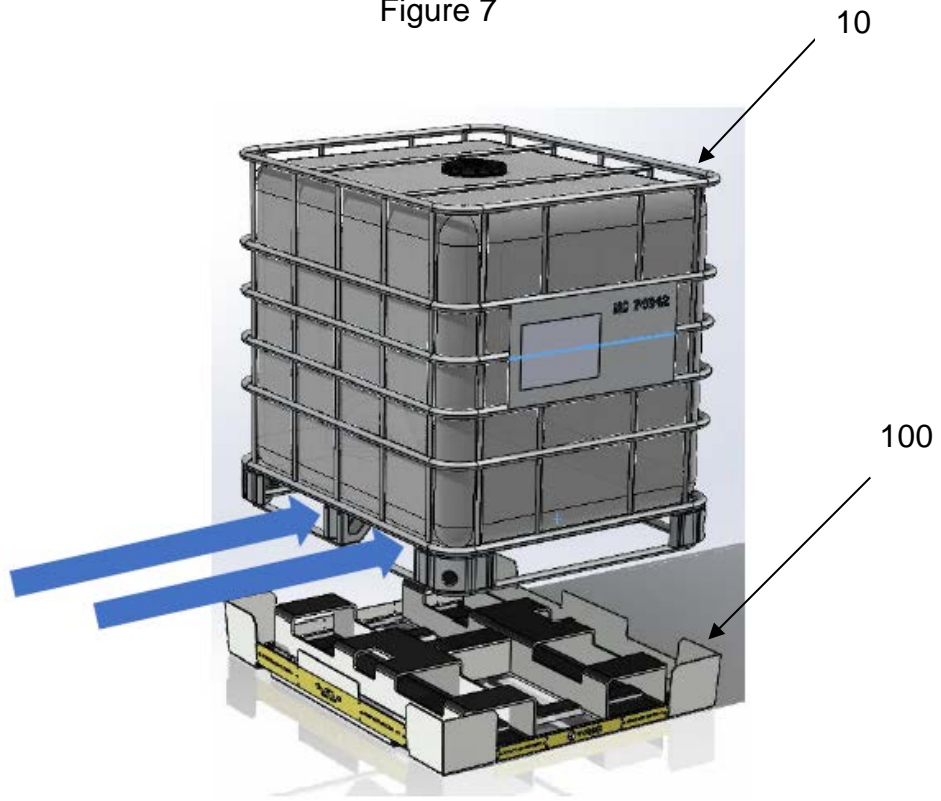

Figure 8



Figure 9



Figure 10

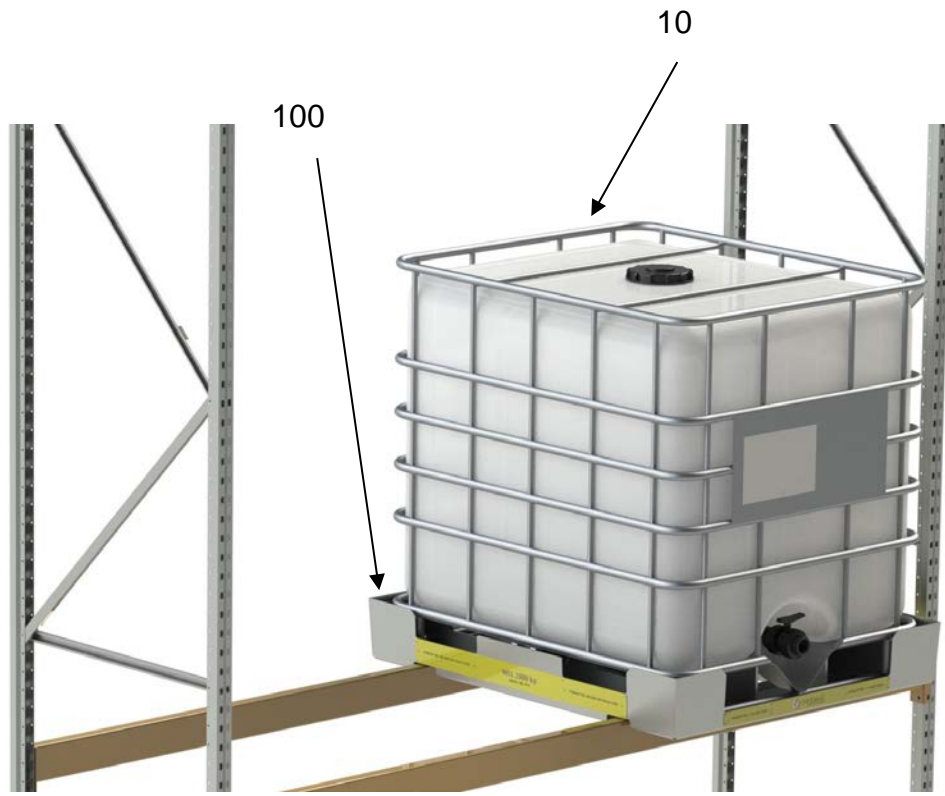

Figure 11

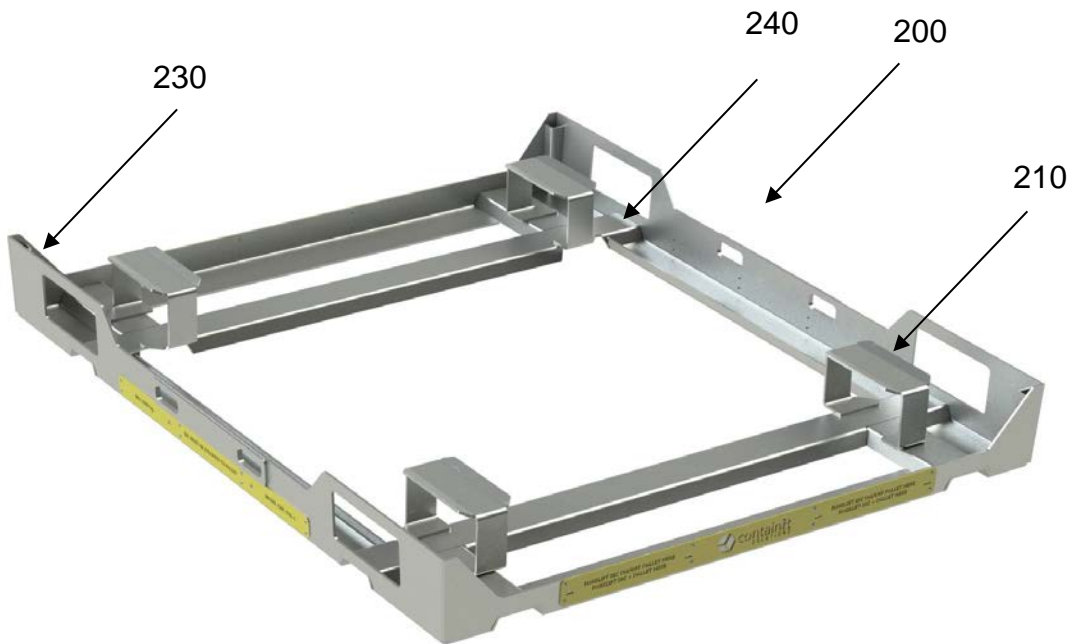

Figure 12

2024216404 28 Aug 2024



Figure 13



Figure 14

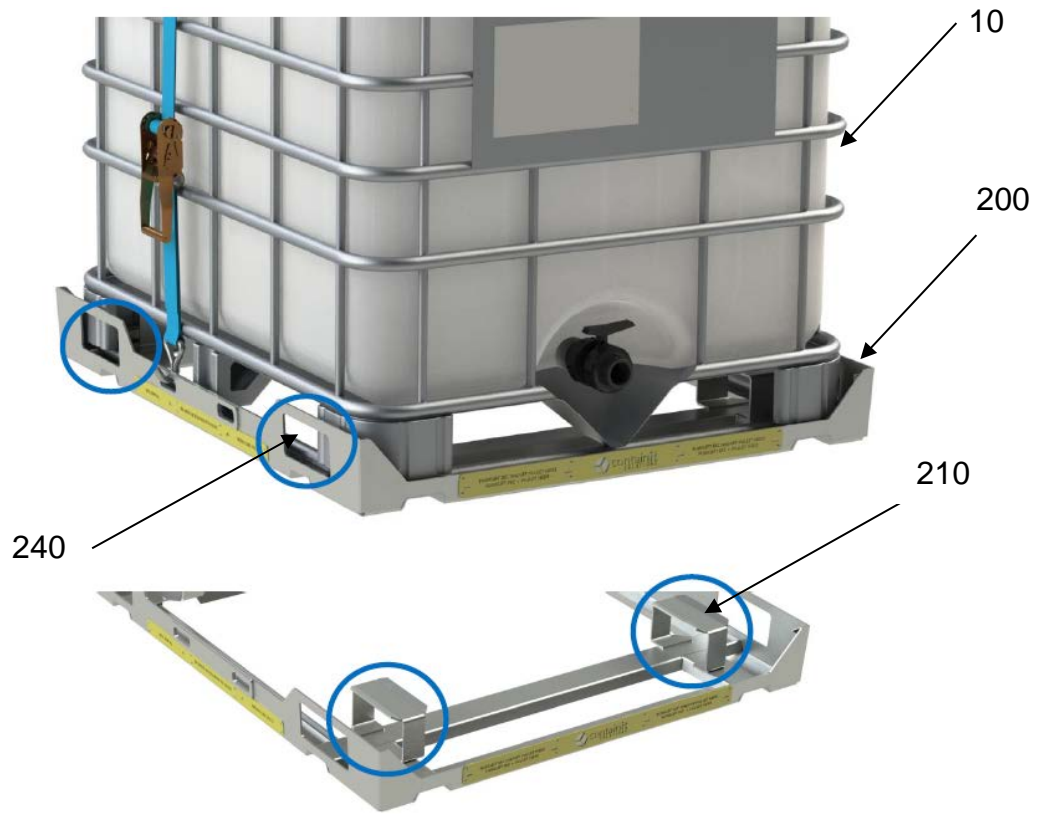

Figure 15

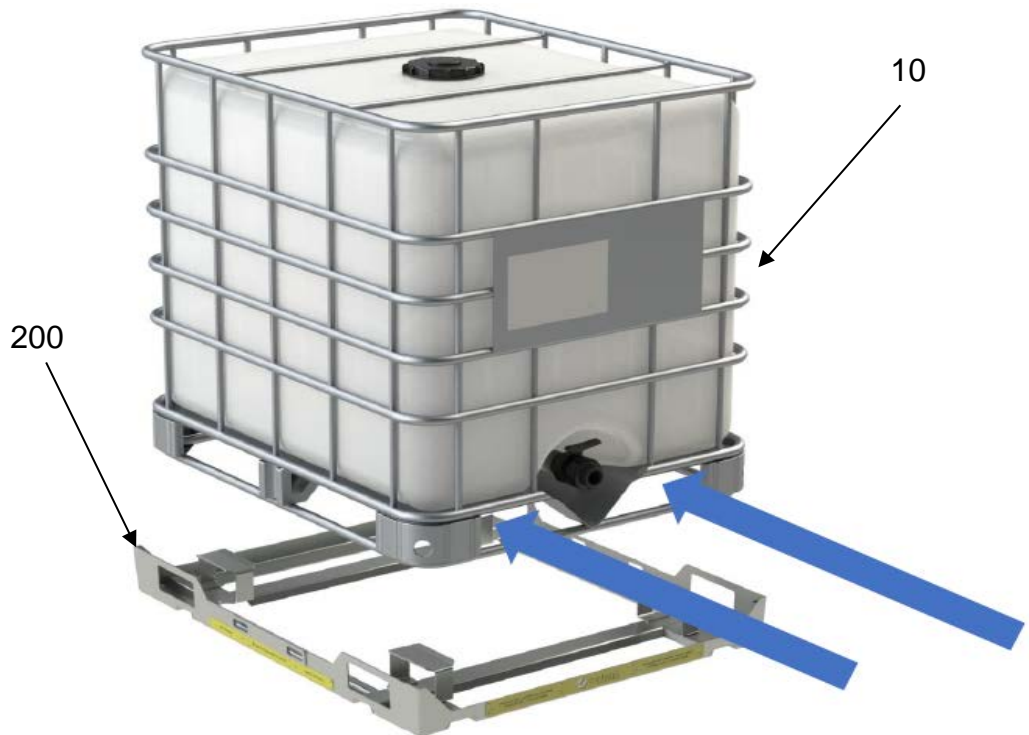

Figure 16



Figure 17

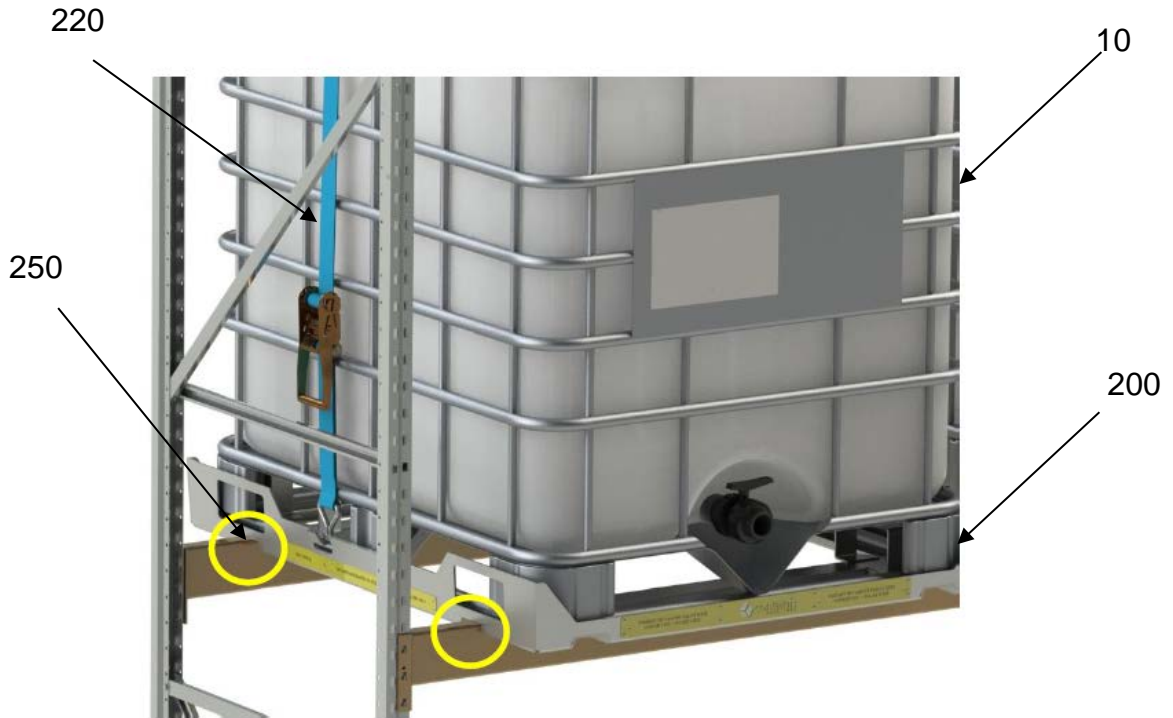

Figure 18

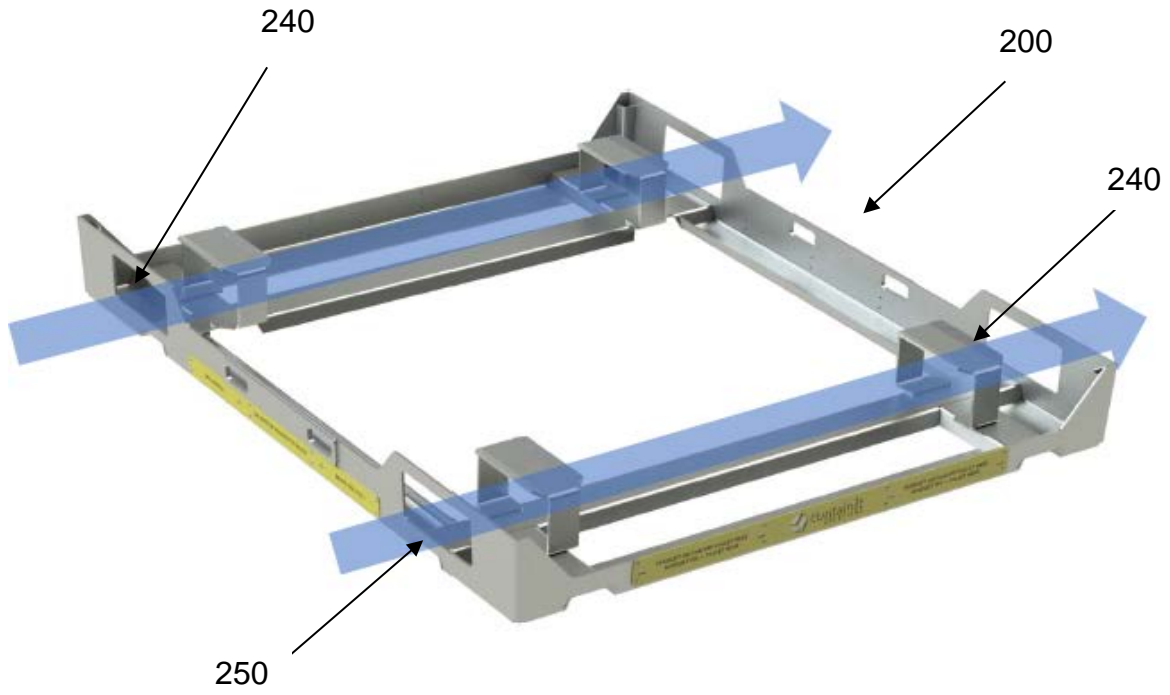

Figure 19

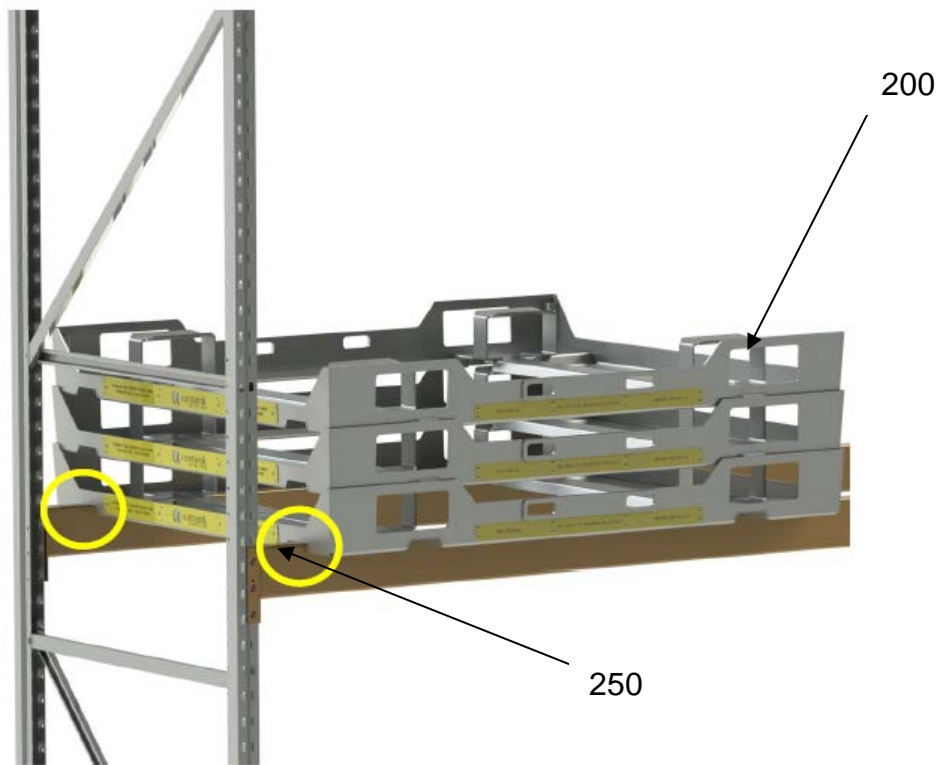

Figure 20