

**(12) STANDARD PATENT APPLICATION** (11) Application No. **AU 2024219441 A1**  
**(19) AUSTRALIAN PATENT OFFICE**

(54) Title  
**Locking Mechanism For Containers**

(51) International Patent Classification(s)  
**B65D 77/04** (2006.01) **A47K 10/32** (2006.01)  
**A47K 5/06** (2006.01) **B65D 83/08** (2006.01)

(21) Application No: **2024219441** (22) Date of Filing: **2024.09.05**

(43) Publication Date: **2026.03.19**

(43) Publication Journal Date: **2026.03.19**

(71) Applicant(s)  
**Hysential Pty Ltd**

(72) Inventor(s)  
**Ugrinovski, Steven**

(74) Agent / Attorney  
**Steven Ugrinovski, 8 Hartog Ct, Shell Cove, NSW, 2529, AU**

# Locking mechanism for Containers

## Abstract

A locking mechanism for a container is disclosed herein, designed to secure a cover over the consumable materials. The locking mechanism comprises a body capable of vertical movement, snap projections are connected to the body to engage with the cover, and springs to bias the body into position. Additionally, a key lock system, featuring a key insert and sliding rod, interacts with the body to release the cover when engaged by the key lock. The mechanism ensures the cover remains locked until the user requires to. The locking mechanism allows the container to operate with or without the key to unlock.

2024219441

05 Sep 2024

# Locking mechanism for Containers

## Technical field

[0001] The present invention relates to a lockable container arrangement consisting of a base part and a cover that is pivotally attached to the base part so that it can be locked in a closed position with respect to it. To keep the cover closed, a locking mechanism comprising a lock and key arrangement is provided in the base of the container.

## Background

[0002] Containers such as dispensers for consumable materials in kitchens, toilets or similar are often required to be locked, in particular when located in more public places. It has become necessary to be able to lock the container to prevent the entire contents of the container from being removed by an unauthorized person, while at the same time allowing successive feeding out of for example contained paper, washing substances or the like. Re-filling of the container is then carried out by authorized persons having access to a key for unlocking the container or dispenser. However, for containers intended for smaller workplaces, for private use or similar it may be an inconvenience to keep track of the respective key and to unlock the container for refilling of the consumable material. As the task of refilling may be carried out by more than one person it is often not desirable to lock the container.

[0003] A natural placement of the key is inside the container, but placing the key somewhere in the container without a suitable release means would mean that the key becomes locked inside, in the case that the lock is of the self-locking type with spring-return to the locking position upon closing of the container, which in turn would lead to obvious difficulties.

[0004] WO 92/018733 describes one lock arrangement that addresses this problem. The locking ability is achieved by means of a lock, the main part of which is arranged in the cover and presents a locking cylinder with a slot, in which is arranged a key for locking and unlocking. The lock has a lock catch rotatable by means of the key, said lock catch being adjustable between a locking position and a free position. As part of

the lock there is arranged a locking edge in the console which, in the shown example, is formed by an opening edge portion of an opening arranged in the console. According to this document, the container presents a holder for the key arranged internally, which holder is positioned so that, with the key placed in the holder, the lock is prevented from assuming the locking position. In this free position, the container is maintained closed by a snap-lock that may be opened by hand.

[0005] Given these challenges and considerations, the development of a reliable locking mechanism tailored to containers is imperative. Such a mechanism should not only ensure the security and integrity of the container but also address concerns related to hygiene, safety, and regulatory compliance, thereby enhancing the overall functionality and usability of containers across various applications and environments.

### **Summary**

[0006] The invention relates to lockable container arrangements, in particular dispensers for consumable materials in kitchens, toilets or similar. Dispensers of this type may be intended for rolls or stacks of paper or other wiping materials, or for washing substances such as liquid hand cream, soap or other detergents.

[0007] According to a first embodiment, the lockable container arrangement comprising a base part, a cover pivotally attached to the base part for displacement between a closed position in which the cover and the base delimit a substantially enclosed space and an open position. The arrangement further comprises a lock mechanism mounted on base of the container, said locking mechanism comprising a lock catch operable from the exterior of the container, which lock catch engages a receiving portion to lock the container. This locking mechanism consists of snap projections connected to a body, which can move vertically to engage or disengage the cover. Additionally, springs are incorporated to bias the snaps into position.

[0008] The locking mechanism further incorporates a key lock system, comprising a key insert and sliding rod. When a key is inserted and turned and pushed, or

alternatively key is inserted and turned in first direction, which keeps the key lock in the unlocked position, and pressed, the sliding rod interacts with a protrusion on the body, causing it to move downward and release the cover. Upon removal of the manual force on the key lock, the sliding rod disengages with the body and springs return the locking mechanism to its initial position, securing the cover once again.

[0009] In order to close the cover, the user simply pushes the cover towards its closed position. A beveled front surface on the snap will first come into contact with the receiving portion. An additional force applied to the front wall of the cover will cause the beveled surface to displace the lock catch relative to the receiving portion. During this displacement the cover on the lock cylinder is pushed towards an intermediate position between the opposing surfaces.

#### **Brief description of figures**

[0010] Notwithstanding any other forms which may fall within the scope of the present invention, preferred embodiments of the disclosure will now be described, by way of example only, with reference to the accompanying drawings in which: to the drawings, in which:

[0011] Fig. 1 illustrate a back perspective view of a container, according to embodiments as disclosed herein;

[0012] Fig. 2 illustrate a front perspective view of a container with cover open, according to embodiments as disclosed herein;

[0013] Fig. 3 illustrate an exploded view of a container, according to embodiments as disclosed herein;

[0014] Fig.4a-4c illustrates the working of the key lock for the container, according to the embodiment disclosed herein;

[0015] Fig. 5-6 illustrate a view disclosing the locking mechanism of the container, according to embodiments disclosed herein;

[0016] Fig. 7a-7b illustrate a back view of the dispenser with locking mechanism in locked position, according to embodiments as disclosed herein.

[0017] Fig. 8 illustrate a side perspective view of a container with cover open, according to embodiments as disclosed herein;

[0018] Fig. 9 illustrate an internal view of the cover of a container, according to current embodiment as disclosed herein.

### **Detailed description of the embodiments**

[0019] The example embodiments herein and the various features and advantageous details thereof are explained more fully with reference to the non-limiting embodiments that are illustrated in the accompanying drawings and detailed in the following description. Descriptions of well-known components and processing techniques are omitted to not unnecessarily obscure the embodiments herein. The description herein is intended merely to facilitate an understanding of ways in which the example embodiments herein can be practiced and to further enable those of skill in the art to practice the example embodiments herein. Accordingly, this disclosure should not be construed as limiting the scope of the example embodiments herein.

[0020] FIG. 1 shows a schematic illustration of a lockable container arrangement according to one embodiment of the invention. The container arrangement in FIG. 1 shows a dispenser for consumable materials in kitchens, toilets or similar. The container of this type can be used for rolls or stacks of paper such as hand towels or other wiping materials. Although any suitable type of lock cylinder may be used for a lock used in the invention.

[0021] Referring now to fig. 2-3 a container 100 is shown. The container 100 comprises cover 10 for securing a cartridge 20 used for storing a dispensing substance. The cover 10 comprises a front wall 11, two side walls 12, 13, a lower wall 14 with a dispensing opening 15 and an upper wall 16.

[0022] In another embodiment, the container 100 doesn't need a cartridge to support the consumable materials. The consumable materials such as toiled paper rolls, wipes and similar consumable materials can be stored below the cover without the need of a cartridge.

- [0023] The container 100 further comprises a base 30 comprising a plurality of apertures 32 for connecting fasteners 40 for securing the container 100 on a wall. The cover 10 is pivotally secured to the base 30.
- [0024] Referring now to fig. 3, the container 100 further comprises a locking mechanism 40 secured between the cartridge 20 and base 30 for holding the cover 10 in lock position.
- [0025] As seen in fig.4-5 the locking mechanism 40 comprises a plurality of snaps projections 41 connected to a body 42. The body 42 further comprises a protrusion 43 (explained greater in later details). The snap projections 41 along with the body 42 are configured to move in a vertical direction for locking and unlocking the cover 10. In the cover 10, receiving projections 17 are provided in the inner surfaces of the side walls 12,13. The locking mechanism 40 further comprises a plurality of springs 44 for biasing the body 42 when it is in unlocking position.
- [0026] In current embodiment, the snap projections 41 and springs 44 are integral with the body 42. In other embodiments, the snap projections 41, springs 44 and body 42 all can be made from different material and joined together with known joining methods such as mechanical fastening, adhesives, other known joining methods.
- [0027] Now with reference to fig. 4a-4c, the working mechanism of the key lock 45 will be explained. The locking mechanism 40 further comprises a key lock 45. The key lock 45 comprises a key insert 451 for interacting with a key 46. Further, the key lock 45 comprises a sliding rod 47 configured to slide in a vertical direction when key 46 is inserted and rotated in the key lock 45. When the key 46 is rotated one direction, it allows the sliding rod 47 to be pressed and move in vertical direction. When the key 46 is rotated in first direction, the sliding rod 47 can be pressed. The key 45 within the key lock 47 can be rotated in first direction to leave the key lock in unlocked state, which allows the lock to be pressed and move the sliding rod vertically without the key.
- [0028] The key 46 within the key lock 45 can be rotated in direction opposite to the first direction to leave the key lock in locked state, which do not allow the key lock to be pressed and move the sliding rod vertically.

[0029] The sliding rod 47 under the force of key 46 is configured to engage with protrusion 43. The engagement of the sliding rod 47 with the protrusion 43 moves the body 42 and the snap projections into a lower position which unlocks the cover.

[0030] Now with reference to fig. 6a-6b, 7a-7b the working of the locking mechanism will be explained in greater details.

[0031] In reference to fig. 6a and 6b, the cover 10 is shown in a locked position. Snap projections 41 engages with counter locking parts 17 in the cover 10 to lock the cover in a locked position. When the cartridge 20 is emptied, the user inserts a key 46 in the key lock 45 and rotates it's in unlock position. When the key lock 45 is turned in an unlock position, the sliding rod 47 in a vertical direction via key 46 or manual force, which further engages with the protrusion 43 to move the body 42 down in vertical direction. The snap projection 41 move together with the body 42, disengaging with the locking projections present in the cover 10, thus opening the cover 10. The cover 10 is pivotally connected to the base 20 at the lower position.

[0032] When the force is disengaged from the sliding rod 47, the springs 44 biases the body 42 and thus the snap projections 41 into an upper position to lock the cover 10 when attached with the base 20.

[0033] The foregoing description of the specific embodiments will so fully reveal the general nature of the embodiments herein that others can, by applying current knowledge, readily modify and/or adapt for various applications such specific embodiments without departing from the generic concept, and, therefore, such adaptations and modifications should and are intended to be comprehended within the meaning and range of equivalents of the disclosed embodiments. It is to be understood that the phraseology or terminology employed herein is for the purpose of description and not of limitation. Therefore, while the embodiments herein have been described in terms of embodiments, those skilled in the art will recognize that the embodiments herein can be practiced with modification within the spirit and scope of the embodiments as described herein.

[0034] The foregoing description and accompanying figures illustrate the principles, embodiments and modes of operation of the invention. However, the invention should not be construed as being limited to the particular embodiments discussed above. Additional variations of the embodiments discussed above will be appreciated by those skilled in the art.

[0035] Therefore, the above-described embodiments should be regarded as illustrative rather than restrictive. Accordingly, it should be appreciated that variations to those embodiments can be made by those skilled in the art without departing from the scope of the invention as defined by the following claims.

[0036] The terms “comprises”, “comprising”, “includes”, “including”, “having” and their conjugates mean “including but not limited to” and indicate that the components listed are included, but not generally to the exclusion of other components. Such terms encompass the terms “consisting of” and “consisting essentially of”.

[0037] The phrase “consisting essentially of” means that the composition or method may include additional ingredients and/or steps, but only if the additional ingredients and/or steps do not materially alter the basic and novel characteristics of the composition or method.

[0038] As used herein, the singular form “a”, “an” and “the” may include plural references unless the context clearly dictates otherwise. For example, the term “a compound” or “at least one compound” may include a plurality of compounds, including mixtures thereof.

[0039] The word “exemplary” is used herein to mean “serving as an example, instance or illustration”. Any embodiment described as “exemplary” is not necessarily to be construed as preferred or advantageous over other embodiments or to exclude the incorporation of features from other embodiments.

[0040] The word “optionally” is used herein to mean “is provided in some embodiments and not provided in other embodiments”. Any particular embodiment of

the disclosure may include a plurality of “optional” features unless such features conflict.

[0041] It is appreciated that certain features of the disclosure, which are, for clarity, described in the context of separate embodiments, may also be provided in combination in a single embodiment. Conversely, various features of the disclosure, which are, for brevity, described in the context of a single embodiment, may also be provided separately or in any suitable subcombination or as suitable in any other described embodiment of the disclosure. Certain features described in the context of various embodiments are not to be considered essential features of those embodiments, unless the embodiment is inoperative without those elements.

[0042] Although the disclosure has been described in conjunction with specific embodiments thereof, it is evident that many alternatives, modifications and variations will be apparent to those skilled in the art. Accordingly, it is intended to embrace all such alternatives, modifications and variations that fall within the spirit and broad scope of the disclosure.

[0043] All publications, patents and patent applications mentioned in this specification are herein incorporated in their entirety by reference into the specification, to the same extent as if each individual publication, patent or patent application was specifically and individually indicated to be incorporated herein by reference. In addition, citation or identification of any reference in this application shall not be construed as an admission that such reference is available as prior art to the present disclosure. To the extent that section headings are used, they should not be construed as necessarily limiting.

# Locking mechanism for Containers

## Claims

1. A locking mechanism for a container, comprising:

A body configured to move vertically;

At least one snap projection connected to the body, the snap projection configured to engage with a cover of the container to secure the cover in a locked position;

At least one spring configured to bias the body into a predetermined position; and  
a key lock system comprising a key insert and at least one sliding rod,

the least one sliding rod configured to interact with a protrusion on the body, causing the body to move vertically and disengage the snap projections from the cover.

2. The locking mechanism of claim 1, wherein the key lock system is configured to engage the sliding rod with the protrusion with or without the key.
3. The locking mechanism of claim 1 and claim 2, wherein the key within the keylock can be rotated in first direction to leave the key lock in unlocked state, which allows the lock to be pressed and move the sliding rod vertically without the key.
4. The locking mechanism of claim 1 and claim 2, wherein the key within the keylock can be rotated in direction opposite to the first direction to leave the key lock in locked state, which do not allow the key lock to be pressed and move the sliding rod vertically.

5. The locking mechanism of claim 1, wherein the cover is pivotally connected to a base of the container.
6. The locking mechanism of claim 1, wherein the snap projections are integral with the body.
7. The locking mechanism of claim 1, wherein the snap projections, springs, and body are made from different materials and joined together with known joining methods.
8. The locking mechanism of claim 1, wherein the key lock system is configured to engage the sliding rod with the protrusion to unlock the cover when the consumables inside the containers requires replacement.
9. The locking mechanism of claim 1, further comprising counter locking parts within the cover configured to engage with the snap projections to lock the cover in a locked position.
10. The container of claim 7, wherein the cover is configured to pivotally connect to the base at a lower position.

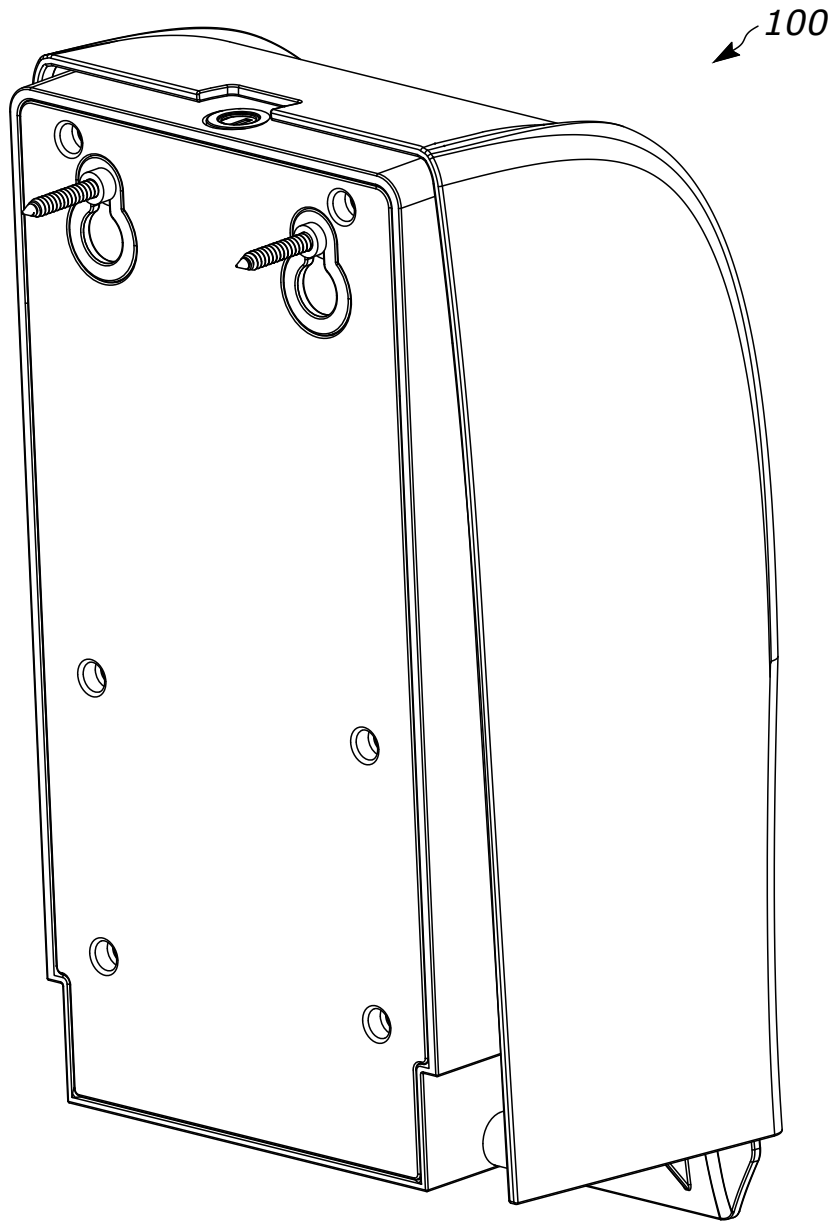

FIG. 1

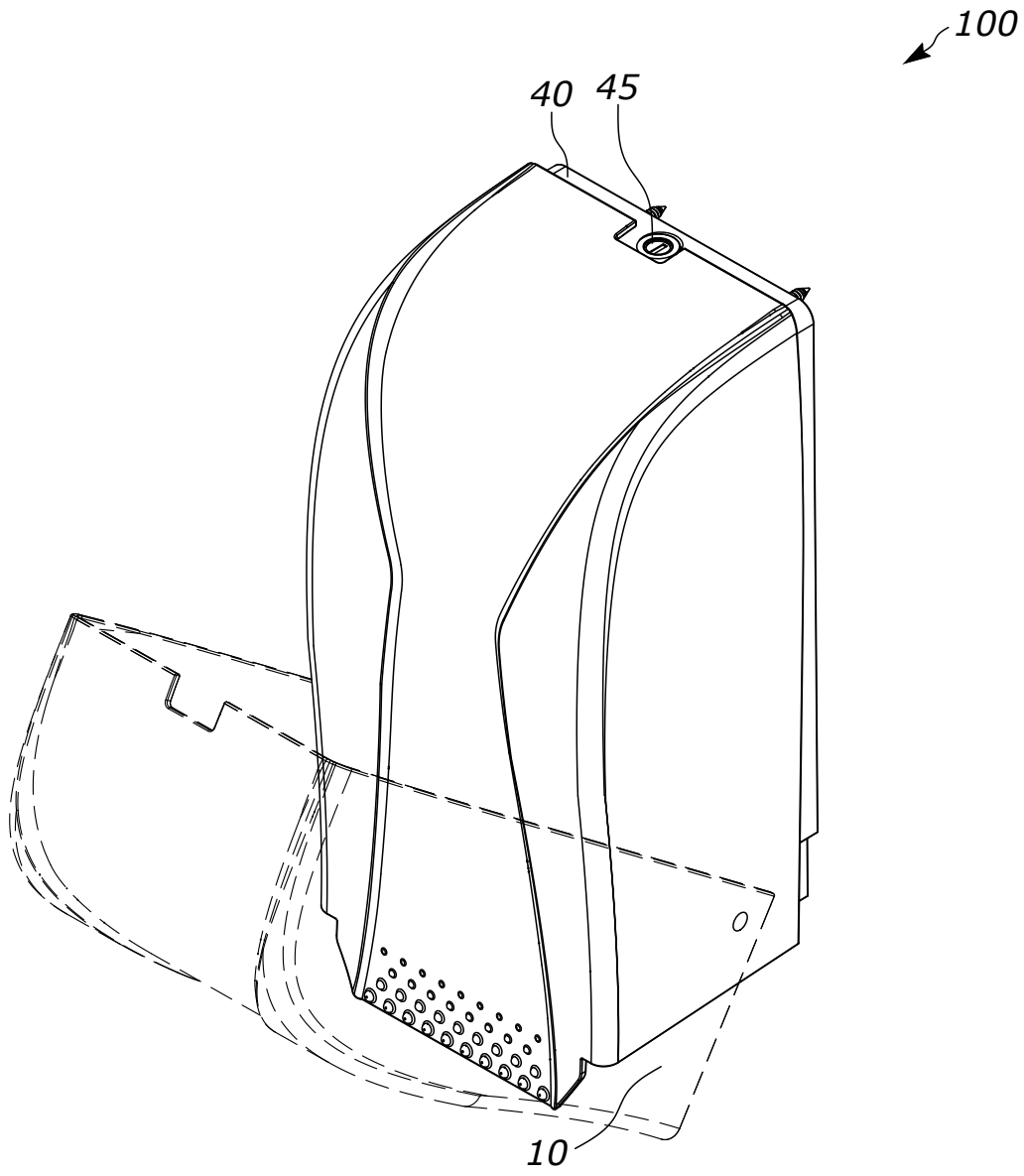

FIG. 2

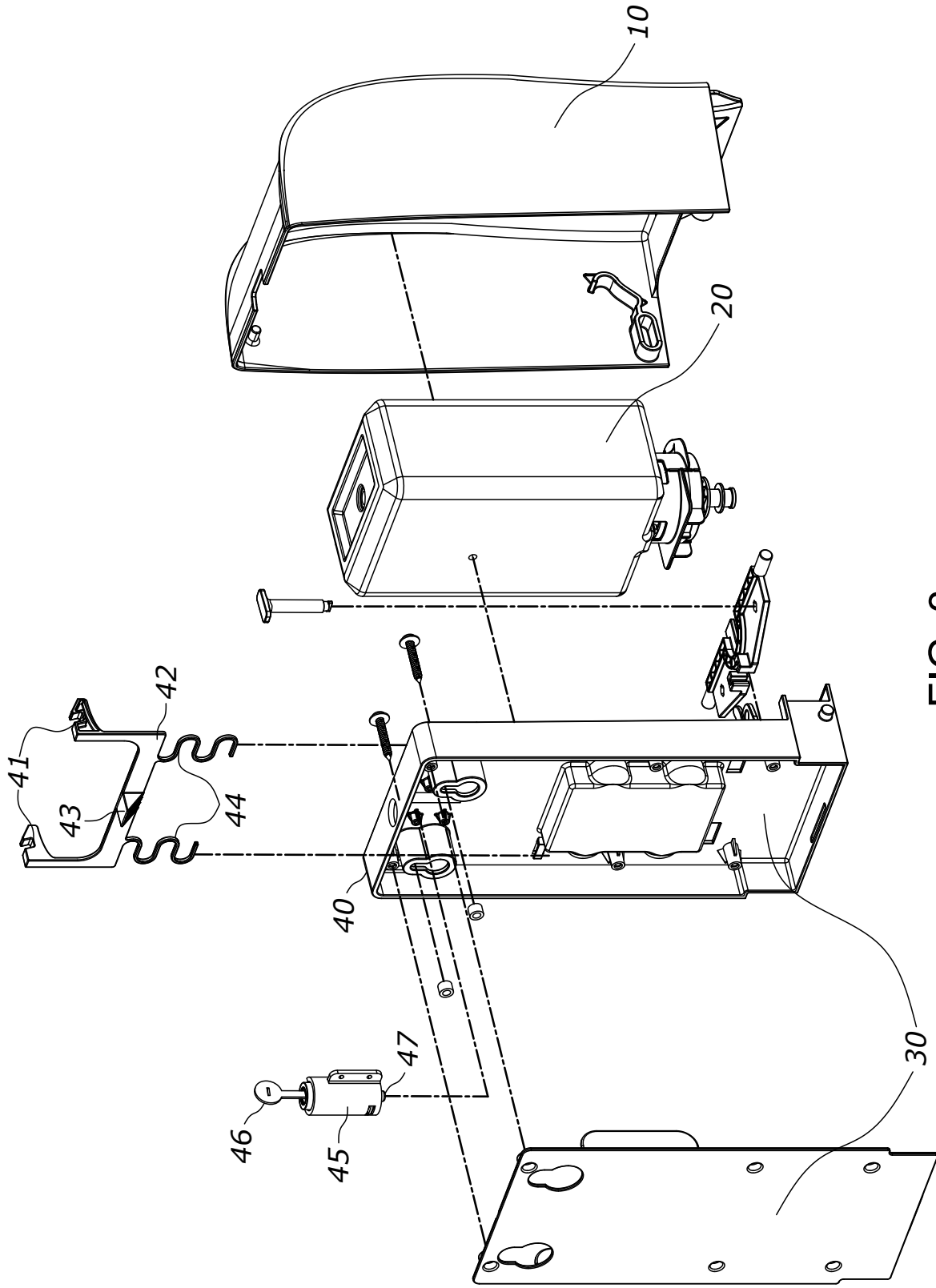

FIG. 3

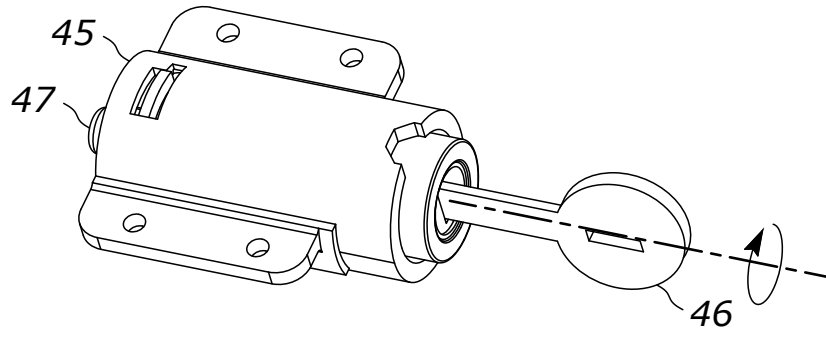

FIG. 4A

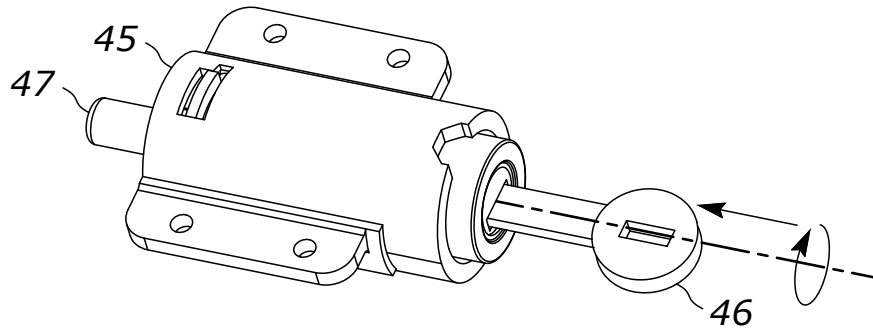

FIG. 4B

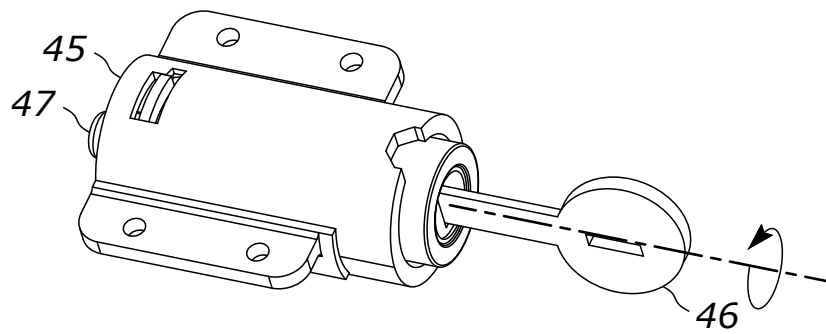

FIG. 4C

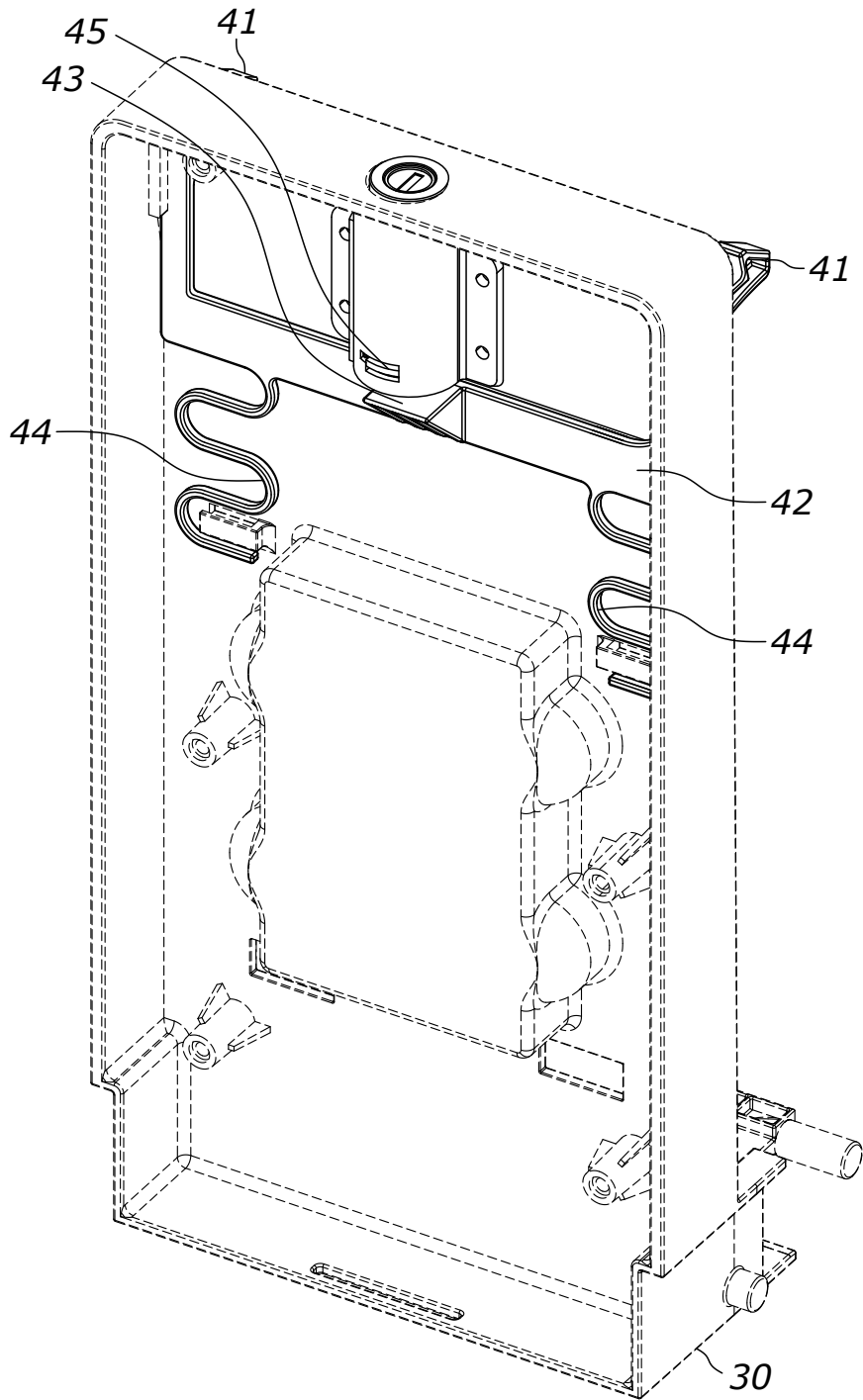

FIG. 5

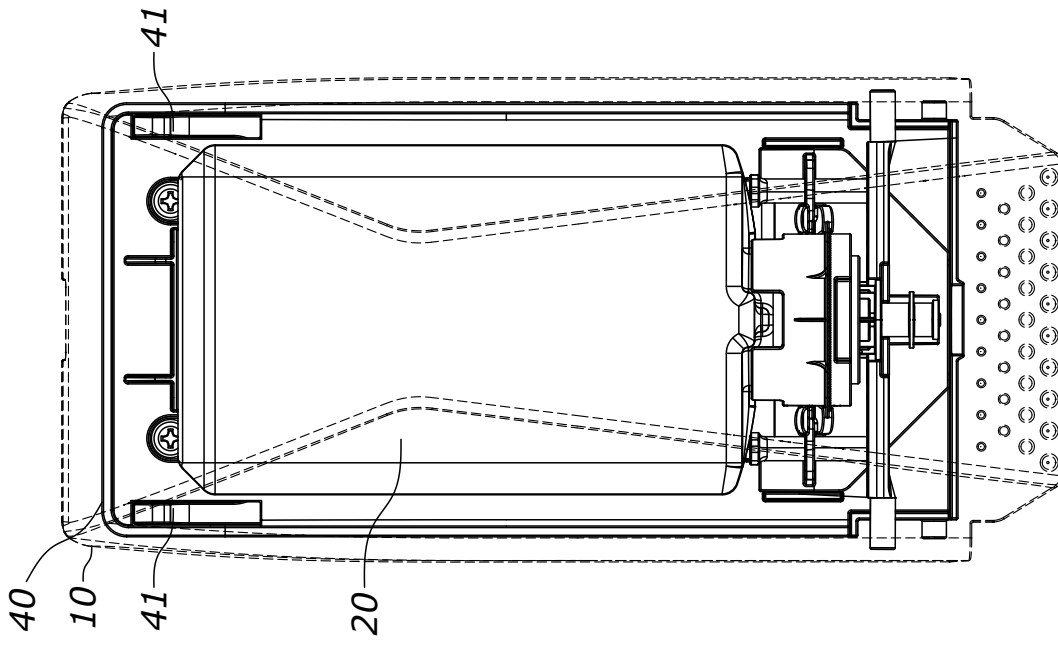

FIG. 6A

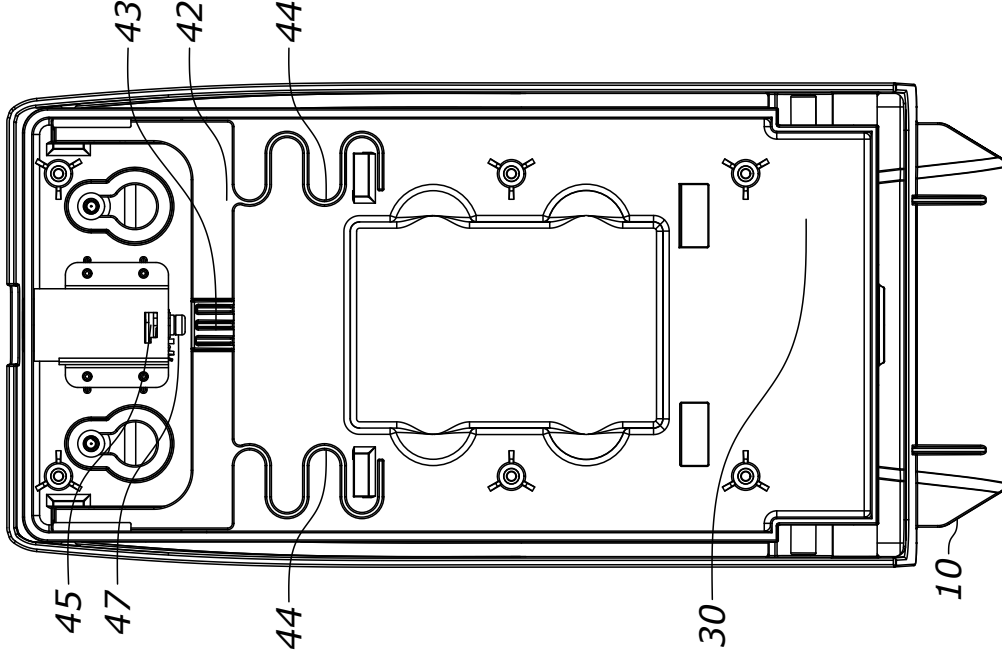

FIG. 6B

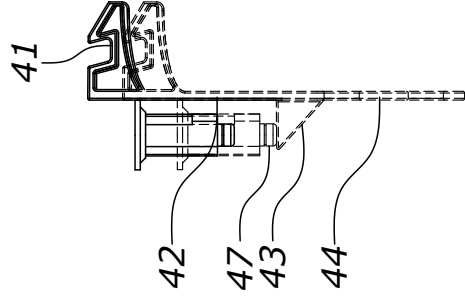

FIG. 7B

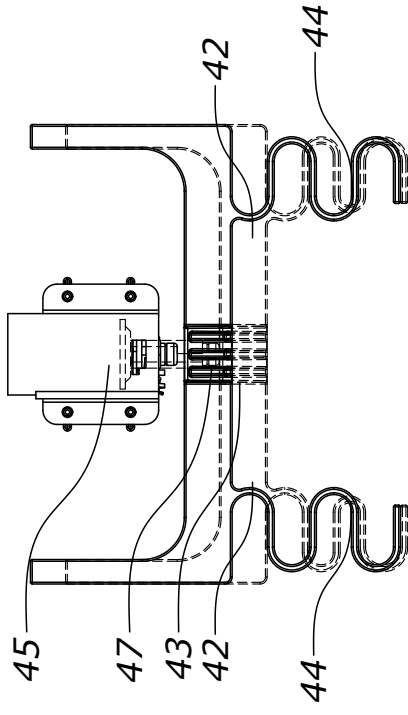

FIG. 7A

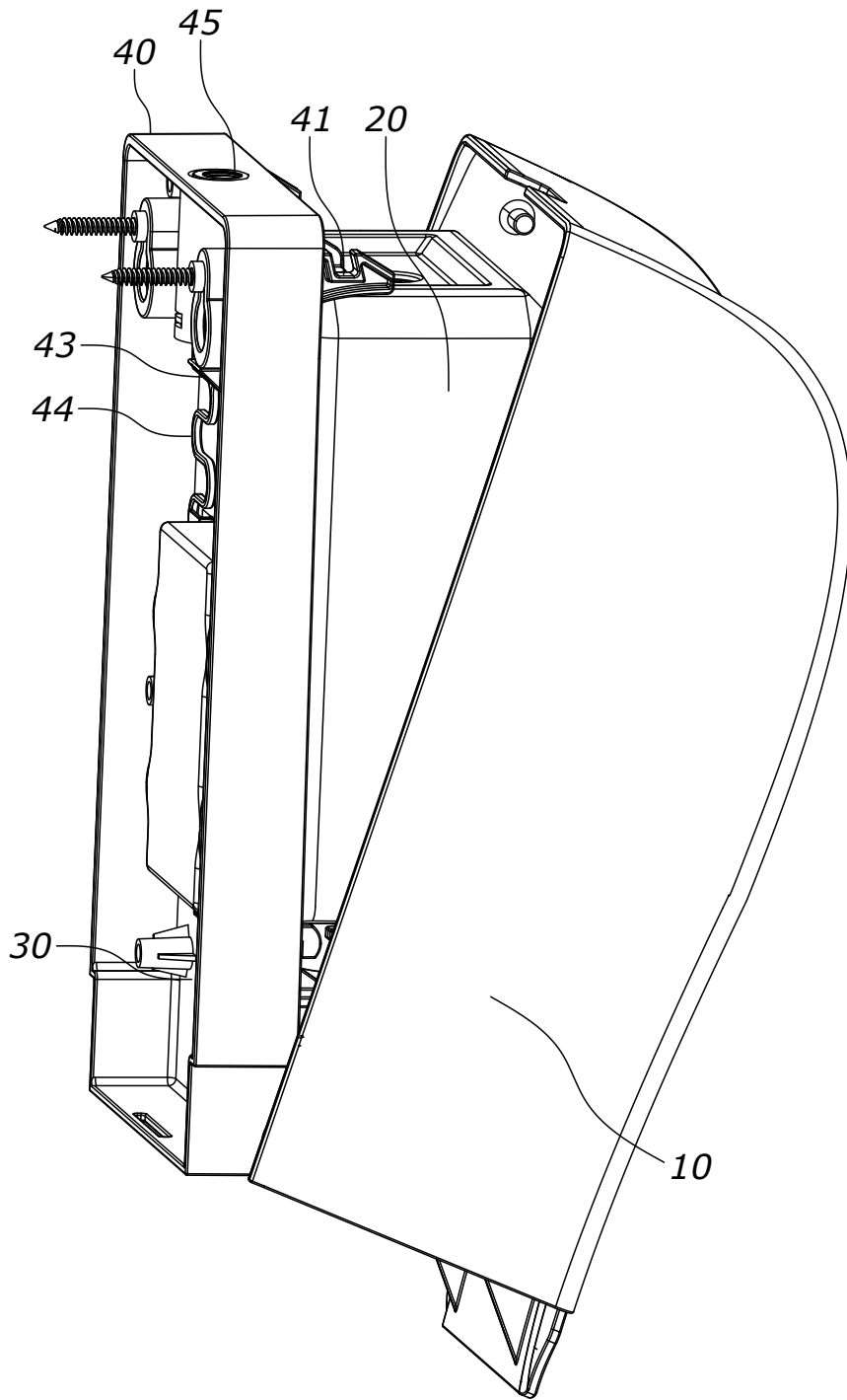

FIG. 8

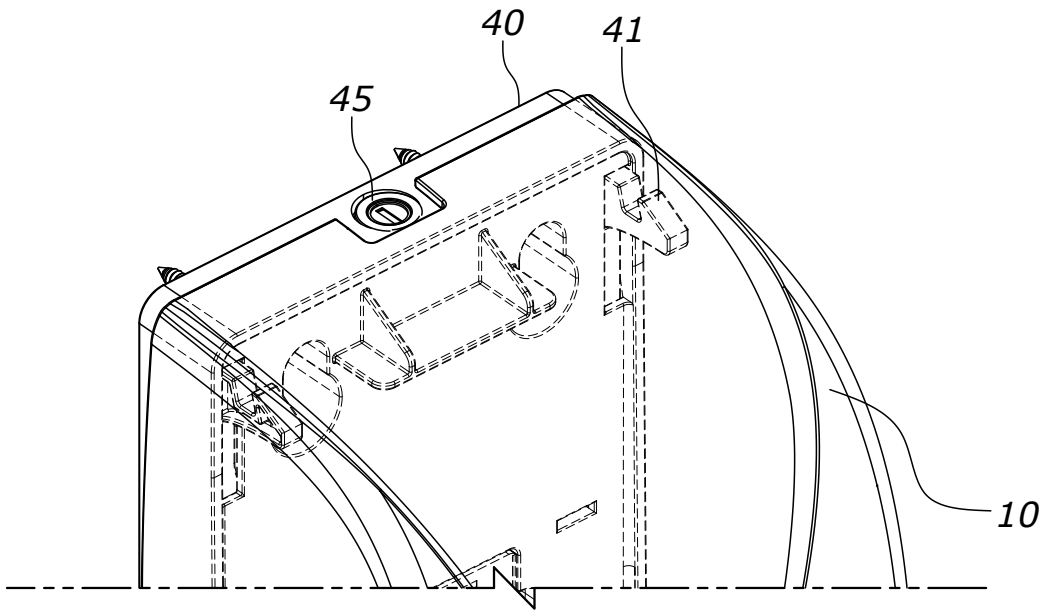

FIG. 9