

(12) STANDARD PATENT APPLICATION (11) Application No. AU 2025213554 A1
(19) AUSTRALIAN PATENT OFFICE

(54) Title
DRYING DEVICE FOR DRYING A MOP COVER OF A CLEANING DEVICE

(51) International Patent Classification(s)
A47L 13/58 (2006.01) **A47L 11/40** (2006.01)

(21) Application No: **2025213554** (22) Date of Filing: **2025.08.05**

(30) Priority Data

(31) Number	(32) Date	(33) Country
102024124409.7	2024.08.27	DE

(43) Publication Date: **2026.03.19**

(43) Publication Journal Date: **2026.03.19**

(71) Applicant(s)
Carl Freudenberg KG

(72) Inventor(s)
HEILAND, Marc

(74) Agent / Attorney
Halfords IP, GPO Box 4212, Sydney, NSW, 2001, AU

Abstract

5 A drying device (10) for drying a mop cover on a carrier plate of a cleaning device is described, comprising a frame (20) with a wringing gap (30) into which the carrier plate with the mop cover can be inserted, and at least one wiping device (40) arranged laterally from the wringing gap (30) and having a wiper (41) for wiping liquid from the mop cover, wherein a sleeve guide is provided on the frame (20) for holding and guiding the wiping device (40), by means of which the wiper (41) can be linearly displaced back and forth
10 between a wringing position narrowing the wringing gap (30) and a position widening the wringing gap (30), and wherein the sleeve guide has at least one sleeve (50a, 50b) with an opening and at least one guide pin which can be inserted through the opening and is slidably mounted in the sleeve (50a, 50b). (60a, 60b). According to the invention, the wiper (41) is arranged
15 relative to the opening of the sleeve (50a, 50b) such that no liquid can enter the opening when wiping liquid from the mop cover.

Fig. 1

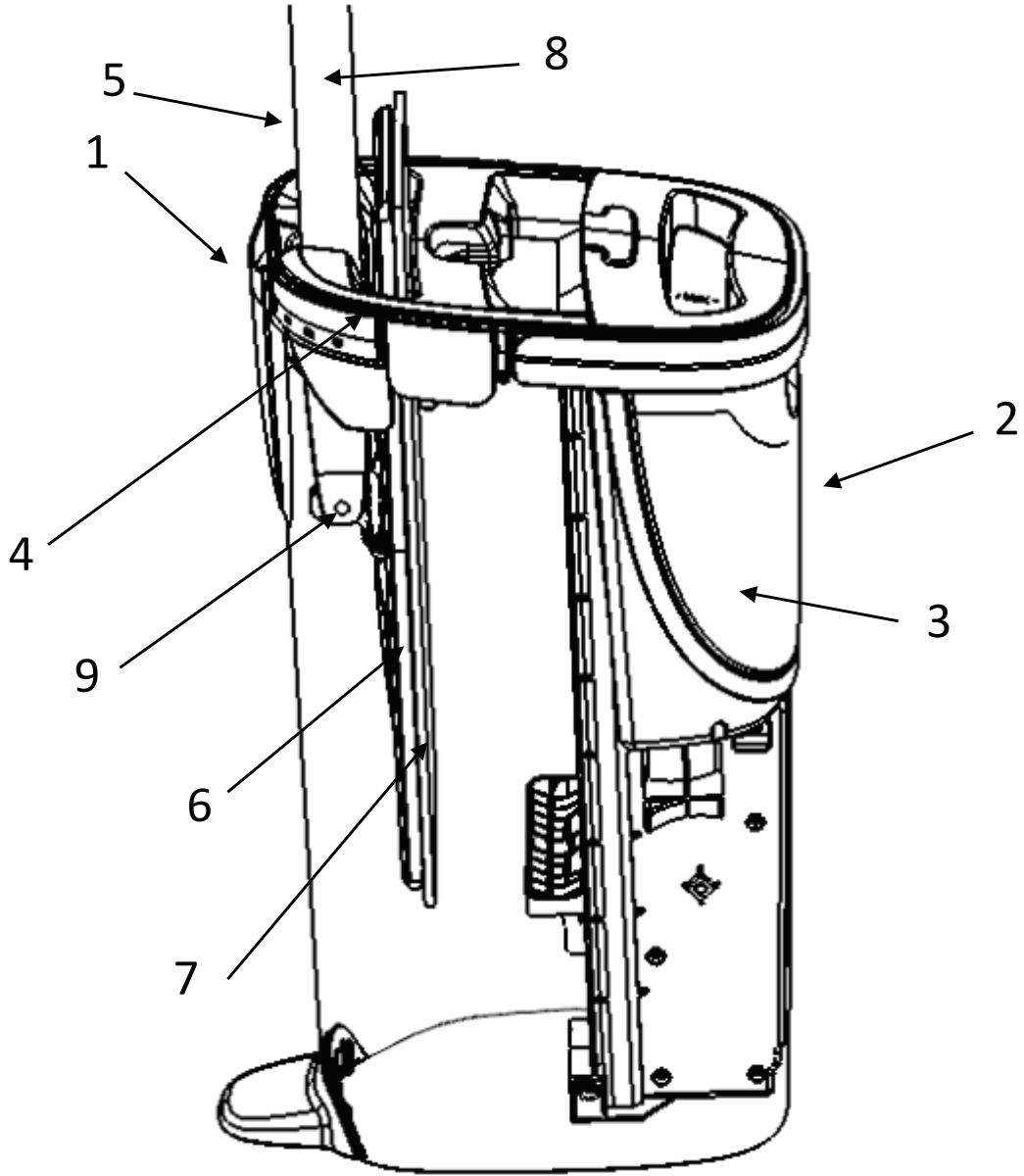

FIGURE 1

Drying device for drying a mop cover of a cleaning device

5

Description

Technical Area

10

The invention relates to a drying device for drying a mop cover on a carrier plate of a cleaning device, comprising a frame with a wringing gap into which the carrier plate with the mop cover can be inserted, and at least one wiping device arranged laterally from the wringing gap with a wiper for wiping liquid from the mop cover, wherein a sleeve guide is provided between the wiping device and the frame, by means of which the wiper can be linearly displaced back and forth between a wringing position narrowing the wringing gap and a position widening the wringing gap, and wherein the sleeve guide comprises at least one sleeve with an opening and at least one guide pin which can be inserted through the opening and is slidably mounted in the sleeve.

20

State of the Art

25

EP 3 446 613 B1 discloses a cleaning system comprising a cleaning device and a bucket with a cleaning and drying device for the cleaning device. The cleaning device is a flat mop with a carrier plate, a mop cover mounted thereon, and a handle connected to the carrier plate via a cardan-like joint. The cleaning and drying devices are designed as separate units. The drying device is mounted on the bucket and has a wringing gap in which a wiper is slidably mounted. For this purpose, the wiper is guided in laterally arranged, inclined guide grooves. The

30

inclination is designed such that the wiper, when moved downwards, narrows the wringing gap and, when moved upwards, widens the wringing gap.

To wring out the mop, the carrier plate of the flat mop with the mop cover is rotated into a vertical position parallel to the handle and inserted into the wringing gap with the narrow side first. The linearly movable wiper is pressed downwards by the mop cover into the horizontal wringing position, narrowing the wringing gap. The mop cover is guided along the wiper in the gap and dried by wiping off the liquid. When the mop is pulled out of the gap again, the wiper is pulled upwards by the friction force of the mop cover and brought into a position above the wringing position, widening the wringing gap. This makes it easier to pull out the flat mop and prevents the bucket from being pulled upwards and lifting off. The next time the flat mop is inserted, the wiper is pressed down again towards the wringing position or it moves back into the wringing position on its own due to gravity.

A disadvantage of the known drying device is that when the liquid is wiped off the mop cover, especially in the case of dirty water, the entire assembly consisting of the wiper and the wiper holder within the frame is flooded with the liquid. In particular, dirty water can also escape through the lateral guide grooves and contaminate the grooves and edges of the lateral outer wall of the drying device in the area of the wiper guide.

In a commercially available cleaning system similar to the one described above, a sleeve guide is provided between the wiping device and the frame, by means of which the wiper can be linearly displaced back and forth at an angle of inclination between the wringing position, which narrows the wringing gap, and the position, which widens the wringing gap. The sleeve guide comprises a sleeve with an opening and a guide pin, which can be inserted through the opening and is slidably mounted in the sleeve, to which the wiper is attached. With this cleaning system, too, dirty water can also enter the sleeve.

The present invention is based on the object of further developing a drying device of the type mentioned at the outset in such a way that contamination of the drying device in the area of the outer wall and the guide elements with dirty water is reliably avoided.

5

Presentation of the Invention

This object is achieved with a drying device having all the features of patent claim 1. Preferred embodiments are described in the subclaims.

10

A drying device according to the invention for drying a mop cover on a carrier plate of a cleaning device comprises a frame with a wringing gap into which the carrier plate with the mop cover can be inserted, and at least one wiping device arranged laterally of the wringing gap and having a wiper for wiping liquid from the mop cover. A sleeve guide is provided on the frame for holding and guiding the wiping device, by means of which the wiper can be linearly displaced back and forth between a wringing position narrowing the wringing gap and a position widening the wringing gap. The sleeve guide comprises at least one sleeve with an opening and at least one guide pin slidably mounted in the sleeve. According to the invention, the wiper is arranged in the wringing position relative to the opening of the sleeve such that no liquid can enter the opening of the sleeve when wiping liquid from the mop cover.

15

20

According to a preferred embodiment of the invention, the wiper is arranged in the wringing position with respect to the vertical below the opening of the at least one sleeve.

25

Surprisingly, it has been shown that this simple measure alone can prevent contamination of the sleeve guide and the components underneath with dirty water.

30

According to a further preferred embodiment of the invention, the sleeve guide comprises two adjacent sleeves and associated guide pins for supporting and guiding the wiper device. This measure significantly reduces the risk of the wiper device tipping when inserting and removing the carrier plate with the mop cover.

Sleeves and pins are inclined relative to the vertical in a manner known per se in such a way that the narrowing or widening of the wringing gap described above is achieved during a linear movement of the wiper.

Preferably, the sleeves are arranged on the frame, and the guide pins are arranged on the wiping device. This has the advantage that the wiping device can be easily inserted into the sleeves from above using the guide pins.

The geometry of the sleeves and guide pins is freely selectable. The cross-sections of the sleeve openings and the guide pins simply need to be matched so that the guide pins can slide smoothly within the sleeves without tilting.

The wiping device comprises at least one wiper. The wiper preferably has the shape of a rectangular plate with a wiping edge on the side facing the wringing gap. The wiper device preferably also comprises a cover element connected to the wiper, which covers the area above the openings of the sleeves. In this case, it has proven advantageous if the guide pins engage the cover element and the wiper is fixed to the side of the cover element facing the wringing gap and extends from there into the wringing gap. In this preferred embodiment, the guide pins move the wiper and the cover element equally. The cover element is preferably dimensioned such that it covers the entire area of the sleeve guide upwards, so that, for example, liquid dripping from the mop cover cannot drip into the sleeve guide.

In this preferred embodiment, the cover element simultaneously acts as a stop for the downward movement of the wiper into the wringing gap. The downward

movement is limited by the cover element resting on the upper ends of the sleeves. The geometry and dimensions are selected such that the wiper is in the wringing position when the cover element is placed on the upper ends of the sleeves. The wiper and the cover element can, for example, be arranged next to one another in the same plane. However, this cannot reliably prevent dirty water from seeping under the cover element and penetrating the sleeves when wiping liquid from the mop cover in the wringing position.

Preferably, the wiper is offset downward relative to the cover element, so that when the cover element is placed in place and reaches its wringing position, the wiper is located below the openings of the sleeves. This reliably prevents dirty water from penetrating the sleeves when wiping the liquid off the mop cover.

Preferably, the wiper, the cover element and the guide pins are made of the same material and in one piece.

According to a further preferred embodiment of the invention, the cover element and the wiper have a downwardly extending drip edge on the outer peripheral edge.

The drip edge prevents dirty water from creeping around the edge of the cover element and the wiper, thereby dripping into the area of the sleeve guide and, in particular, into the sleeve openings, thereby contaminating them. At the drip edges, the dirty water drips vertically downwards, for example, into a designated compartment in a bucket. Drip edges are well known. A suitable geometry and dimensions can be easily found without requiring inventiveness on the part of the person skilled in the art.

Short Description of the Drawing

The invention is described in more detail below with reference to the figures.

5 It shows

Fig. 1: a cleaning system comprising a cleaning container with a cleaning area and a drying area and a flat wiper with a wiper cover when drying the wiper cover according to the prior art;

10

Fig. 2: in a perspective view obliquely from above a drying device according to a preferred embodiment of the invention with partially raised wiping device;

15

Fig. 3: in the same representation as Fig. 1 the drying device with retracted wiping device;

Fig. 4: in perspective view obliquely from below the wiping device according to the preferred embodiment of Figs. 1 and 2.

20

Implementation of the Invention

Fig. 1 shows, without limitation of generality, an example of a cleaning system 1 according to the prior art, in which a drying device according to the invention can be used. The cleaning system 1 shown has a cleaning container 2. In the cleaning container 2, a cleaning area 3 (not described in detail here) and a drying device 4 can be seen, for example. A flat mop 5 with a carrier plate 6 and a mop cover 7 for wiping off liquid is inserted into the drying device 4. The handle 8 of the flat mop and the universal joint 9 are also visible.

30

The drying device 4 can be a drying device according to the invention. It can be easily placed on the cleaning container 2 and secured there, for example, by means of locking means.

5 Fig. 2 shows a drying device 10 according to a preferred embodiment of the invention. The drying device 10 shown has a frame 20 with a wringing gap 30, into which, as shown in Fig. 1, a carrier plate (not shown here) with a mop cover can be inserted from above. In the wringing gap 30, without limiting the generality, there is a wiping device 40 arranged laterally of the wringing gap 30, comprising a wiper 41 for wiping liquid from the mop cover and a cover element 10 70. The wiper 41 is arranged laterally of the cover element 70 and, according to a preferred embodiment of the invention, is offset downwards relative to the latter. The wiper 41 projects laterally into the wringing gap 30. Two guide pins 60a, 60b are arranged on the underside of the cover element 70, which support 15 the cover element 70 with the wiper 41 and move them up and down together. The guide pins 60a, 60b are slidably mounted in associated sleeves 50a, 50b. It can be seen that the sleeves are arranged at an angle relative to the vertical, such that the wringing gap is narrowed by the wiper 41 during the downward movement and widened during the upward movement.

20

According to a further, particularly preferred embodiment of the invention, the cover element 70 and the wiper 41 in the illustrated embodiment have a drip edge 80 extending downwards around their outer peripheral edge. This prevents dirty water impinging on the cover element 70 or the wiper 41 from 25 creeping around the outer peripheral edge and thus entering and contaminating the openings of the sleeves 50a, 50b.

Fig. 3 shows the drying device from Fig. 2 with the wiping device 40 retracted. The same parts are designated by the same reference numerals as in Fig. 2. It 30 can be seen that the cover element 70 covers the area of the sleeve guide at the top.

Fig. 4 shows a perspective view of a wiping device 40 according to the invention. The wiping device 40 has a wiping 41, which is designed as a rectangular plate with a wiping edge 42, and a cover element 70. The guide pins 60a, 60b are arranged on the underside of the cover element 70. Also
5 visible are optionally provided guide elements 90 with an upward movement limit, which engage the frame (not shown here). Also visible is the drip edge 80 arranged on the outer circumference of the wiping device 40.

Claims

- 2025213554 05 Aug 2025
- 5
- 10
- 15
- 20
- 25
- 30
1. Drying device (10) for drying a mop cover on a carrier plate of a cleaning device, comprising a frame (20) with a wringing gap (30) into which the carrier plate with the mop cover can be inserted, and at least one wiping device (40) arranged laterally from the wringing gap (30) with a wiper (41) for wiping liquid from the mop cover, wherein a sleeve guide is provided on the frame (20) for holding and guiding the wiping device (40), by means of which the wiper (41) can be linearly displaced back and forth between a wringing position narrowing the wringing gap (30) and a position widening the wringing gap (30), and wherein the sleeve guide has at least one sleeve (50a, 50b) with an opening and at least one guide pin (60a, 60b) which can be inserted through the opening and is slidably mounted in the sleeve (50a, 50b), characterized in that the wiper (41) is arranged relative to the opening of the sleeve (50a, 50b) such that when wiping liquid from the mop cover no liquid enters the opening.
 2. Drying device according to claim 1, characterized in that the wiper (41) is arranged in the wringing position relative to the vertical below the opening of the at least one sleeve-shaped element (50a, 50b).
 3. Drying device according to claim 1 or 2, characterized in that the sleeve guide comprises two sleeves (50a, 50b) and associated guide pins (60a, 60b).
 4. Drying device according to at least one of claims 1 to 3, characterized in that the sleeve-shaped elements (50a, 50b) are assigned to the frame (20) and the pins (60a, 60b) are assigned to the wiping device (30).
 5. Drying device according to at least one of claims 1 to 4, characterized in that the wiping device (40) comprises a cover element (70).

6. Drying device according to one of claims 1 to 5, characterized in that the wiper (41) and the cover element (70) have a drip edge (8) extending downwards on their outer peripheral edge.

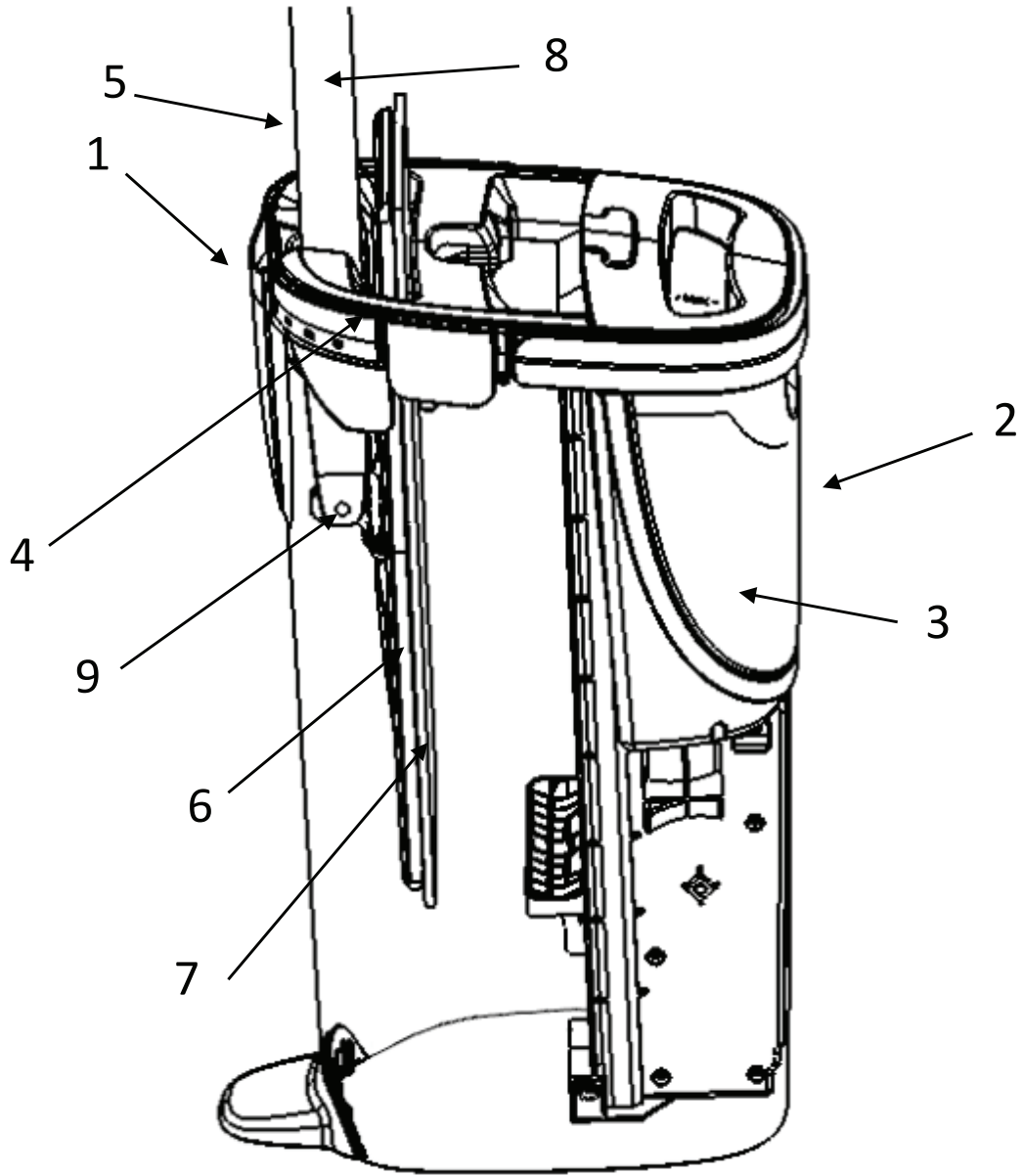

FIGURE 1

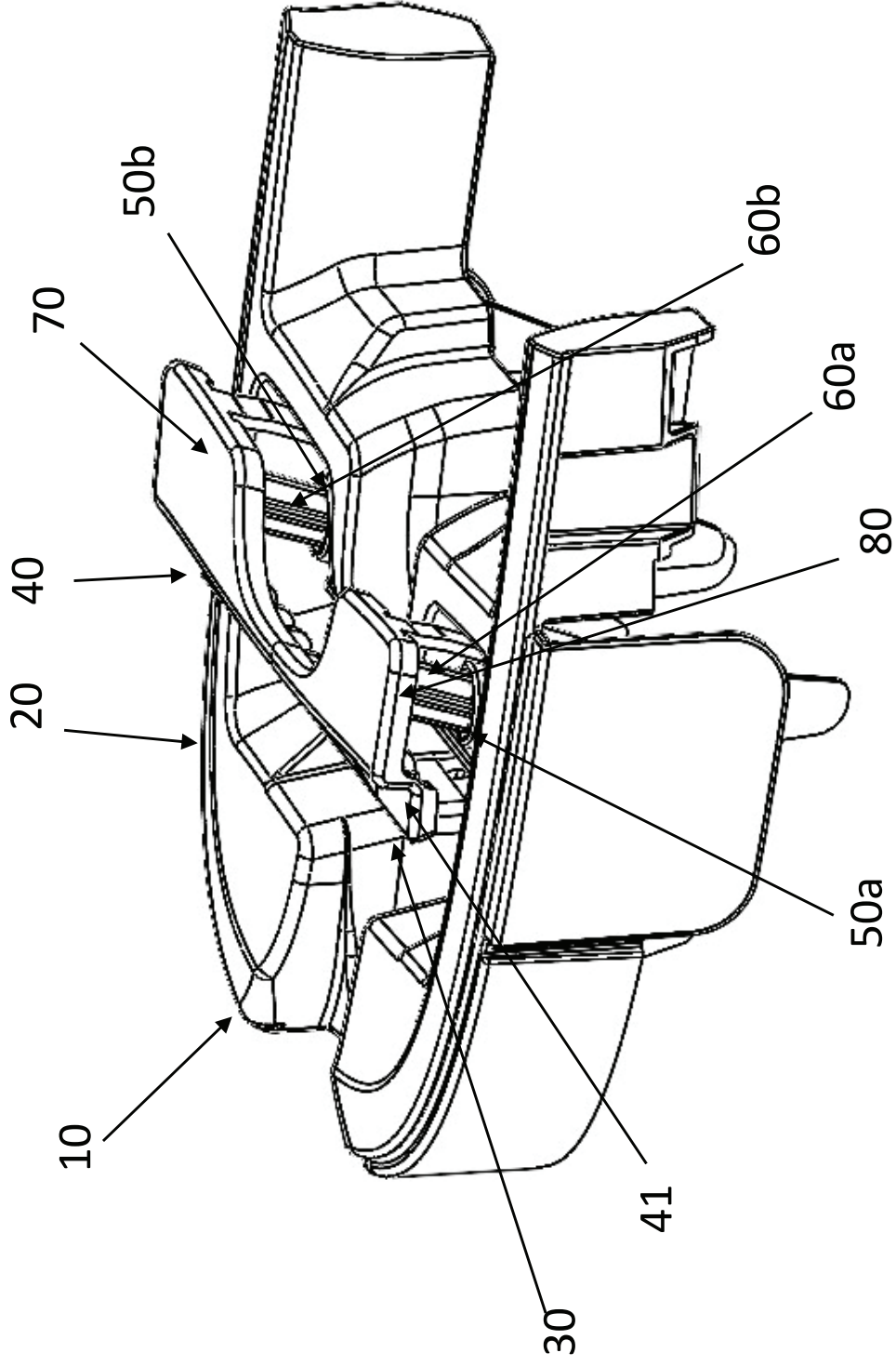

FIGURE 2

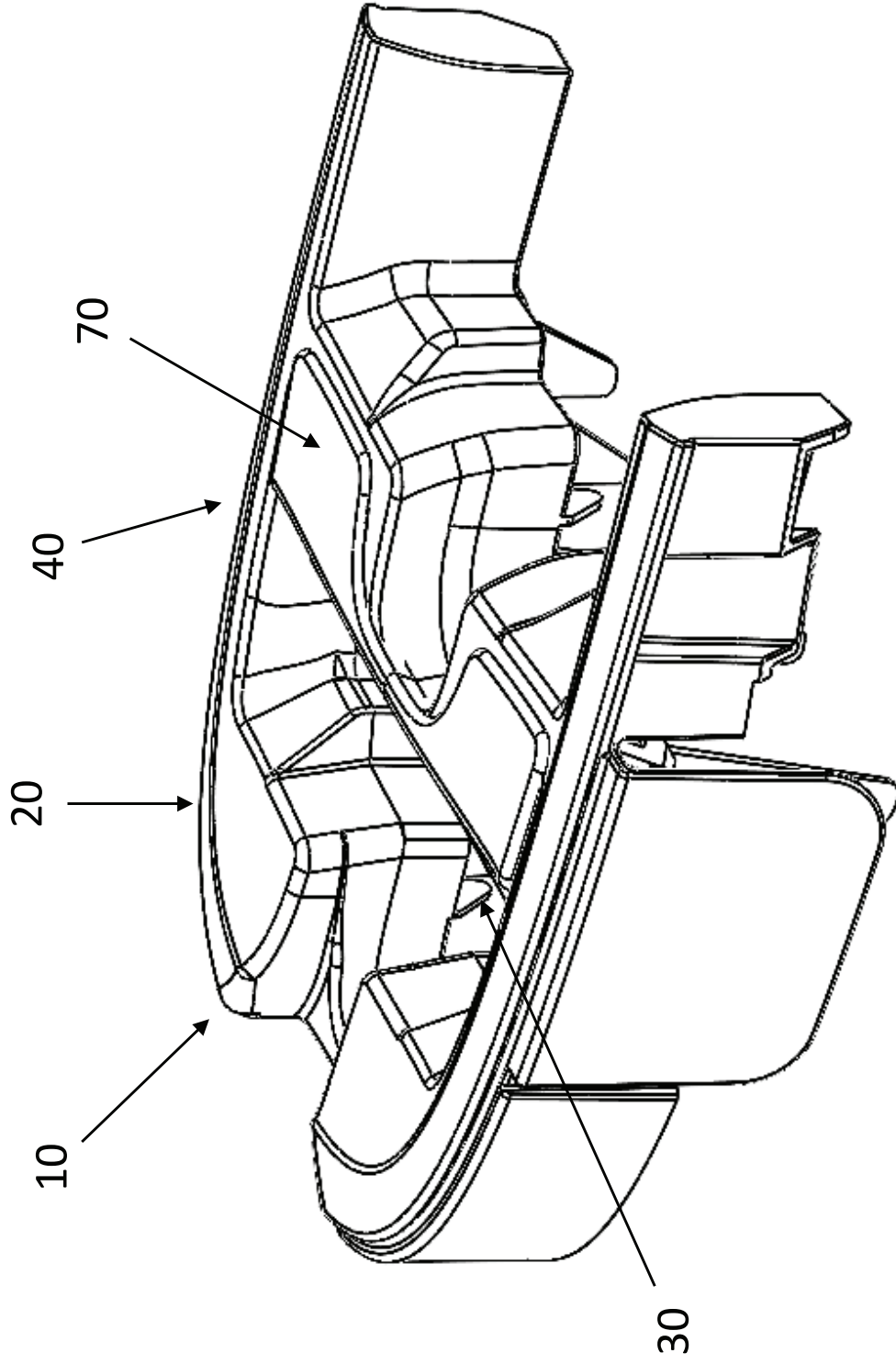

FIGURE 3

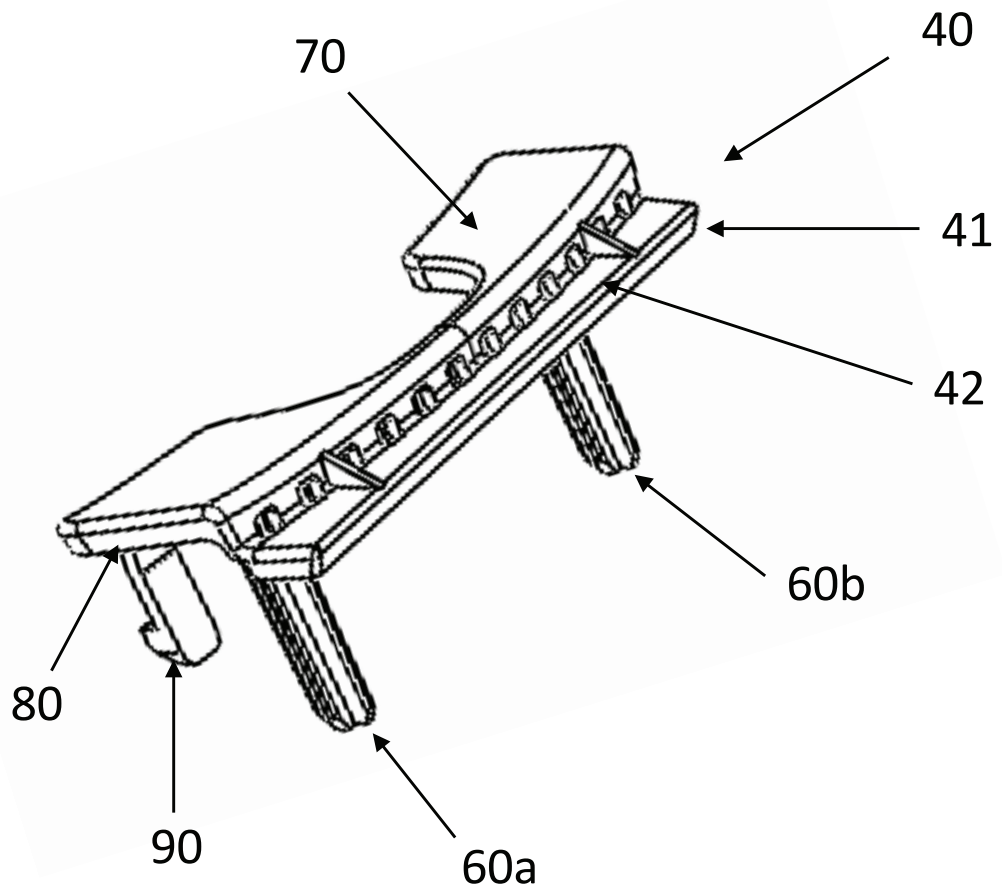

FIGURE 4