

(12) STANDARD PATENT APPLICATION (11) Application No. AU 2025217371 A1
(19) AUSTRALIAN PATENT OFFICE

(54) Title
PROTECTIVE CAP

(51) International Patent Classification(s)
E04C 5/16 (2006.01) **E04G 21/32** (2006.01)

(21) Application No: **2025217371** (22) Date of Filing: **2025.08.15**

(30) Priority Data

(31) Number	(32) Date	(33) Country
63/687,919	2024.08.28	US

(43) Publication Date: **2026.03.19**

(43) Publication Journal Date: **2026.03.19**

(71) Applicant(s)
J.O.B. 2023 LLC

(72) Inventor(s)
TRIVISONNO, Jonathan

(74) Agent / Attorney
**IP GATEWAY PATENT & TRADE MARK ATTORNEYS PTY LTD, PO Box 1321,
SPRINGWOOD, QLD, 4127, AU**

ABSTRACT

A safety cap assembly is disclosed having a plastic body having a base and a tube coupled to the base. The tube is shaped and configured to receive an end of an elongated metallic bar, and a reinforcement is embedded in the plastic body. At least a portion of the reinforcement is positioned in the base, and a magnet is positioned proximal to the reinforcement. The magnet is shaped and configured to firmly attract the elongated metallic bar to the safety cap assembly, and a positioning disk is positioned proximal to the magnet. The positioning disk is shaped and configured to position the magnet relative to the plastic body.

FIG. 2

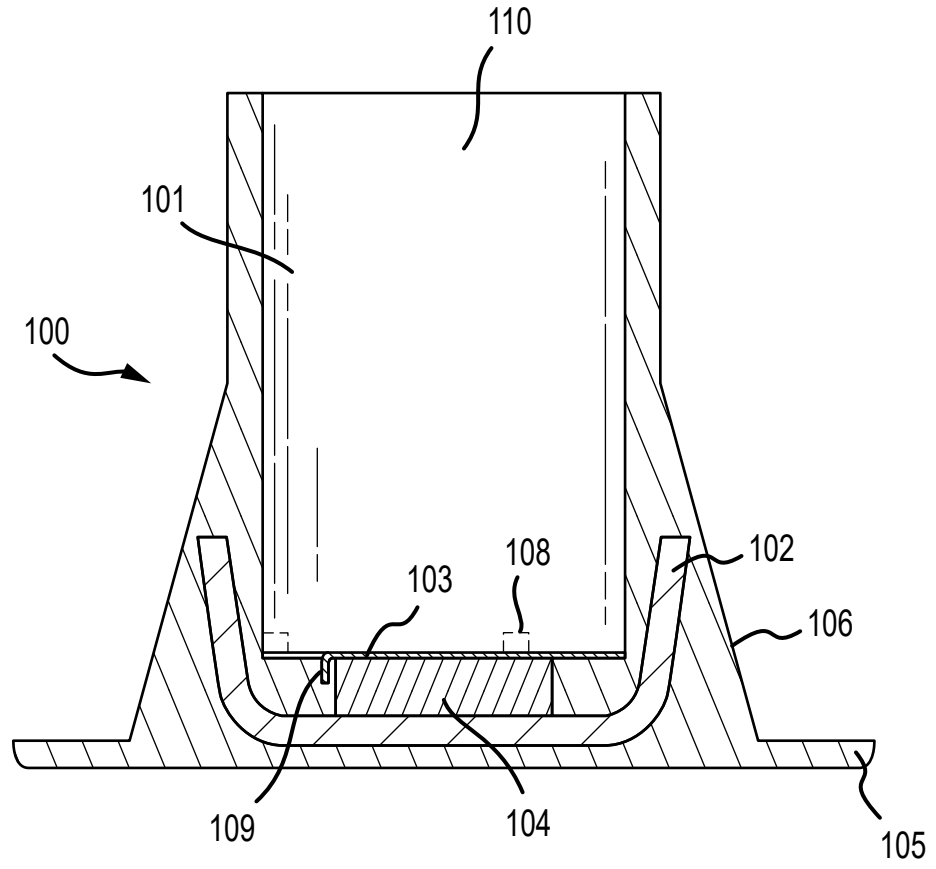

FIG.3

SAFETY CAP

TECHNICAL FIELD

[0001] Embodiments herein are related to safety caps for elongated metallic bars.

BACKGROUND

[0002] In the construction industry, plastic safety caps are well-known; however, and as illustrated in Fig. 1, these caps 500 all use the same design of plastic fins, clips, or zip ties to attach and hold themselves to rebar, stakes, and posts. The plastic fins and/or other components become brittle and break, thus becoming less reliable over time. Contrast the “After” use cap 500 with the “Before” use cap 500 illustrated in Fig. 1. The caps 500 must be thrown away per manufacturer’s instructions if the internal plastic fins become damaged. Construction entities are then forced to choose between safety and increased pressure on thin profits.

[0003] There thus remains a need for a safety cap that is more reliable, reusable, and/or provides other new and inventive products and methods.

SUMMARY

[0004] An exemplary safety cap assembly has a plastic body having a base and a tube coupled to the base, the tube shaped and configured to receive an end of an elongated metallic bar, a reinforcement embedded in the plastic body, wherein at least a portion of the reinforcement is positioned in the base, a magnet positioned proximal of the reinforcement, the magnet shaped and configured to firmly attract the elongated metallic bar to the safety cap assembly, and a positioning disk positioned proximal of the magnet, the positioning disk shaped and configured to position the magnet relative to the plastic body.

[0005] This Summary is provided to introduce a selection of concepts in a simplified form that are further described below in the Detailed Description. This Summary is not intended to identify key features or essential features of the claimed subject matter, nor is it intended to be used as an aid in determining the scope of the claimed subject matter. The claimed subject matter is not limited to implementations that solve any or all disadvantages noted in the Background.

BRIEF DESCRIPTION OF THE DRAWINGS

[0006] A protective cap in accordance with the invention may be implemented in several different forms. It will be convenient to hereinafter describe several embodiments of the invention in detail with reference to the accompanying drawings. The purpose of providing this detailed description is to instruct people having an interest in the subject matter of the invention how to carry the invention into practical effect. However, it is to be clearly understood that the specific nature of this detailed description does not supersede the generality of the preceding summary section. In the drawings:

[0007] FIG. 1 illustrates top perspective views of the prior art before and after use;

[0008] FIG. 2 is a side perspective view of an embodiment of the safety cap affixed to rebar;

[0009] FIG. 3 is a side section view of the safety cap;

[0010] FIG. 4 is a top view of the safety cap; and

[0011] FIG. 5 is a top view of an embodiment of a plate suitable for use in the safety cap.

DETAILED DESCRIPTION

[0012] As further background, the teachings of the following publications are incorporated herein by reference for all proper purposes: US5381636A, <https://www.industrialsafetyproducts.com/>, US20170314270A1, US20180298613A1, and <https://www.varicap.org/product/varicap/>.

[0013] An impalement prevention cap or cover, also referenced herein as a safety cap assembly or simply cap, is now described in detail. As illustrated in Fig. 2, the cap 100 may be installed on the end of an elongated metallic bar, such as, for example, rebar 200, posts, or round stakes to prevent a person from being impaled due to a fall or contact in construction or in general industry. The cap 100 may also be attached to larger posts, rebar, metal stakes, or metal conduits to help provide caution to personnel working in the area as to not damage the object itself or injure personnel. For the purposes of this document, the term “proximal” shall refer to an open end of the cap assembly 100, e.g. the top of the assembly 100 shown in Fig 3, with the term “distal” referencing the other end, such as the bottom shown in Fig. 3, unless otherwise stated. The term “sideways” shall refer to a right or left side in the orientation in Fig. 3 unless otherwise stated.

[0014] With reference now to Figs. 3-5, a safety cap assembly 100 may have a plastic body 101, a reinforcement 102, a magnet 104, and a positioning disk 103.

[0015] The plastic body 101 may have a base 105 and a tube coupled to the base, the tube shaped and configured to receive an end of an elongated metallic bar. In some embodiments, the

elongated metallic bar may be one of the following: a rebar section, a beam, a rod, a pole, a shaft, a rail, a nail, a pin, a post, or a stake.

[0016] As shown in Fig. 4, the base 105 may be substantially square or rectangular in shape. The base 105 may have a plurality of straight sides shaped and configured to prevent the safety cap from rolling when positioned sideways. The plastic body 101 and/or base 105 may have reinforcing features 106 as illustrated in Fig. 2. The plastic body 101 may be substantially polypropylene plastic.

[0017] The tube 107 may be substantially circular in nature. The tube 107 may have a thicker wall adjacent the base 105, as most clearly shown in Fig. 2. The tube 107 may be coupled to the base 105, or the tube 107 may be unitary with the base 105. That is, in some embodiments, the plastic body 101 comprising the base 105 and tube 107 is a unitary piece. For example, the tube 107 and base 105 may be manufactured as a single component, such as by injection molding.

[0018] The reinforcement 102 may be embedded in the plastic body 101, wherein at least a portion of the reinforcement 102 is positioned in the base 105. The reinforcement 102 may provide strength to the cap assembly 100 and prevent, as an example, an elongated metallic bar such as a section of rebar 200 from punching through the cap assembly 100. The reinforcement 102 may have a cupped shape having a flat base and a wall shaped to encircle at least a portion of the end of rebar section. See Fig. 3. The reinforcement 102 may be made of metal. The reinforcement 102 may be made of a material that is stronger than the plastic body 101, such as a different plastic having different properties. The reinforcement 102 may be stamped metal. The reinforcement 102 may be fully embedded in the plastic body 101.

[0019] As shown clearly in Fig. 3, the magnet 104 may be positioned proximal of the reinforcement 102. The magnet 104 may be shaped and configured to firmly attract the elongated metallic bar to the safety cap assembly 100. The magnet 104 may be substantially in the shape of a circular disk. See Fig. 4. The magnet 104 may be embedded in the base of the plastic body 101. The magnet 104 may be selected to have a hold strength of at least 5 lbs. The magnet 104 may be selected to have a hold strength of at least 10 lbs. In some embodiments, the magnet 104 may be selected to have a hold strength of at least 20 lbs. In some embodiments, the magnet 104 may be selected to have a hold strength of at least 30 lbs. In some embodiments, the magnet 104 may be selected to have a hold strength of up to 100 lbs. In some embodiments, the magnet 104 is a unitary piece. In some embodiments, the magnet 104 has a steel encasing (not shown).

[0020] Continuing with Figs. 3-5, the positioning disk 103 may be positioned proximal of the magnet 104. The positioning disk 103 may be shaped and configured to position the magnet 104 relative to the plastic body 101. The positioning disk 103 may also be shaped and configured to

position the magnet 104 relative to the reinforcement 102. The positioning disk 103 may be shaped and configured to provide injection molding matching during manufacture. That is, the positioning disk 103 may assist in providing a precise alignment and fit between the two halves of an injection mold when they close together during the injection molding process.

[0021] In some embodiments, a portion of the positioning disk 103 is embedded in the plastic body 101.

[0022] In some embodiments, the positioning disk 103 has a first plurality of tabs 109 extending distally, as illustrated in Fig. 3, whereby the positioning disk 103 is configured to engage the magnet 104. The positioning disk 103 may be configured to hold the magnet 104 in place during manufacture. For example, the positioning disk may assist in preventing the magnet 104 from moving about during an injection molding process. In some embodiments, the tabs 109 may be stamped in a flat metallic sheet and folded distally to engage the magnet 104.

[0023] In some embodiments, the positioning disk 103 has a second plurality of tabs 108 extending proximally, whereby the positioning disk 103 is configured to engage the tube of the plastic body 101. The tabs 108 may be embedded in the plastic body 101 as illustrated, such as, for example, during an injection molding process. In some embodiments, the positioning disk 103 is a metallic protective sheet. In some embodiments, the positioning disk 103 is shaped and configured to prevent cracking of the plastic body 101 when rebar 200 is rammed against the base of the cap assembly 100. In some embodiments, the tabs 108 may be stamped in a flat metallic sheet and folded proximally to engage the plastic body 101.

[0024] In some embodiments, the positioning disk 103, magnet 104, and reinforcement 102 are at least partially embedded in the plastic body 101. That is, in some embodiments, at least some portion of the positioning disk 103, magnet 104, and reinforcement 102 may be directly affixed to the plastic body 101, such as through injection molding or gluing.

[0025] In embodiments disclosed herein, the cap 100 may be secured to an elongated metallic bar by a magnet that is at least partially embedded inside a poly plastic injected molded cap/cover. The cap 100 may conform with industry standard dimensions to fit specific sizes of elongated metallic bars. A metal cover or disk 103 adjacent the magnet may aid in the protection of the magnet while also aiding in the ability for the magnet to maintain its magnetism with other metal objects. Metal such as reinforcement 102 may also be embedded inside the plastic cap/cover to ensure there is reduced risk of impalement if the safety cap has a person fall on it.

[0026] Because magnets are generally made of pressed materials, the magnet 104 may be protected by a thin sheet of metal such as disk 103 to ensure pieces do not fall out or become dislodged if the magnet 104 breaks.

[0027] Embodiments disclosed herein may have fewer modes of failure and allow for a more diverse range of sizes of metal to cover.

[0028] Embodiments disclosed herein may reduce or eliminate end user installation issues such as not seating the cap on to protruding metal fully. Embodiments herein may be configured for coupling a more diverse range of sizes of elongated metallic bars than traditional caps. The addition of the magnet with a steel cover may add additional impalement protection due the added internal metal being thicker than industry standard.

[0029] Embodiments disclosed herein may eliminate the need for plastic fins to secure the cap to elongated metallic bars, and may reduce or eliminate the user error issue of installation and damage of a critical component, reduce housekeeping on job sites, and/or allow for various sizes of elongated metallic bars to be used without damaging the interior portion of the cap. Magnet 104 may provide consistent performance and allow the user to install without having to worry about it falling off the impalement object. The cap 100 may function in horizontal and vertical applications where gravity affects the performance of the traditional style of rebar cap that uses plastic fins or other mechanical means to secure the cap.

[0030] Each of the various elements disclosed herein may be achieved in a variety of manners. This disclosure should be understood to encompass each such variation, be it a variation of an embodiment of any apparatus embodiment, a method or process embodiment, or even merely a variation of any element of these. Particularly, it should be understood that the words for each element may be expressed by equivalent apparatus terms or method terms—even if only the function or result is the same. Such equivalent, broader, or even more generic terms should be considered to be encompassed in the description of each element or action. Such terms can be substituted where desired to make explicit the implicitly broad coverage to which this invention is entitled.

[0031] As but one example, it should be understood that all action may be expressed as a means for taking that action or as an element which causes that action. Similarly, each physical element disclosed should be understood to encompass a disclosure of the action which that physical element facilitates. Regarding this last aspect, the disclosure of a “attachment mechanism” should be understood to encompass disclosure of the act of “attaching” - whether explicitly discussed or not - and, conversely, were there only disclosure of the act of “attaching”, such a disclosure should be understood to encompass disclosure of a “attaching mechanism”. Such changes and alternative terms are to be understood to be explicitly included in the description.

[0032] Moreover, the claims shall be construed such that a claim that recites “at least one of A, B, or C” shall read on a device that requires “A” only. The claim shall also read on a device that requires “B” only. The claim shall also read on a device that requires “C” only. The claim shall also read on a device that requires “A+B”. The claim shall also read on a device that requires “A+B+C”, and so forth.

[0033] Those skilled in the art can readily recognize that numerous variations and substitutions may be made in the invention, its use and its configuration to achieve substantially the same results as achieved by the embodiments described herein.

[0034] Any reference to prior art in the background above or elsewhere in this specification is not and should not be taken as an acknowledgment or any form of suggestion that the referenced prior art forms part of the common general knowledge in Australia or in any other country.

[0035] In this specification, the term “comprising” is intended to denote the inclusion of a stated integer or integers, but not necessarily the exclusion of any other integer, depending on the context in which that term is used. This applies also to variants of that term such as “comprise” or “comprises”.

[0036] Accordingly, there is no intention to limit the invention to the disclosed exemplary forms. Many variations, modifications and alternative constructions fall within the scope and spirit of the invention as expressed in the claims.

CLAIMS:

1. A safety cap assembly, comprising:
 - a plastic body having a base and a tube coupled to the base, the tube shaped and configured to receive an end of an elongated metallic bar;
 - a reinforcement embedded in the plastic body, wherein at least a portion of the reinforcement is positioned in the base;
 - a magnet positioned proximal of the reinforcement, the magnet shaped and configured to firmly attract the elongated metallic bar to the safety cap assembly; and
 - a positioning disk positioned proximal of the magnet, the positioning disk shaped and configured to position the magnet relative to the plastic body.
2. The safety cap of claim 1, wherein:
 - the magnet is embedded in the base of the plastic body.
3. The safety cap of claim 1 or claim 2, wherein:
 - the reinforcement has a cupped shape having a flat base and a wall shaped to encircle at least a portion of the end of the elongated metallic bar.
4. The safety cap of any one of claims 1 to 3, wherein:
 - the positioning disk is a metallic protective sheet.
5. The safety cap of claim 4, wherein:
 - the positioning disk has a first plurality of tabs extending distally, whereby the positioning disk is configured to engage the magnet.
6. The safety cap of claim 4 or claim 5, wherein:
 - the positioning disk has a second plurality of tabs extending proximally, whereby the positioning disk is configured to engage the tube.
7. The safety cap of any one of claims 4 to 6, wherein:
 - a portion of the positioning disk is embedded in the plastic body.
8. The safety cap of claim 7, wherein:

at least a portion of the positioning disk, the magnet, and the reinforcement are embedded in the plastic body.

9. The safety cap of any one of claims 1 to 8, wherein:
the positioning disk is shaped and configured to position the magnet relative to the reinforcement.
10. The safety cap of any one of claims 1 to 9, wherein:
the magnet is selected to have a hold strength of at least 5 lbs.
11. The safety cap of any one of claims 1 to 9, wherein:
the magnet is selected to have a hold strength of at least 10 lbs.
12. The safety cap of any one of claims 1 to 9, wherein:
the magnet is selected to have a hold strength of at least 20 lbs.
13. The safety cap of any one of claims 1 to 9, wherein:
the magnet is selected to have a hold strength of at least 30 lbs.
14. The safety cap of any one of claims 1 to 13, wherein:
the magnet is a unitary piece.
15. The safety cap of any one of claims 1 to 14, wherein:
the plastic body is a unitary piece.
16. The safety cap of any one of claims 1 to 15, wherein:
the base has a plurality of straight sides shaped and configured to prevent the safety cap from rolling when positioned sideways.
17. The safety cap of any one of claims 1 to 16, wherein:
the elongated metallic bar is selected from one of the following: a rebar section, a beam, a rod, a pole, a shaft, a rail, a nail, a pin, a post, or a stake.

18. The safety cap of any one of claims 1 to 17, wherein:
the elongated metallic bar is a rebar section.

500

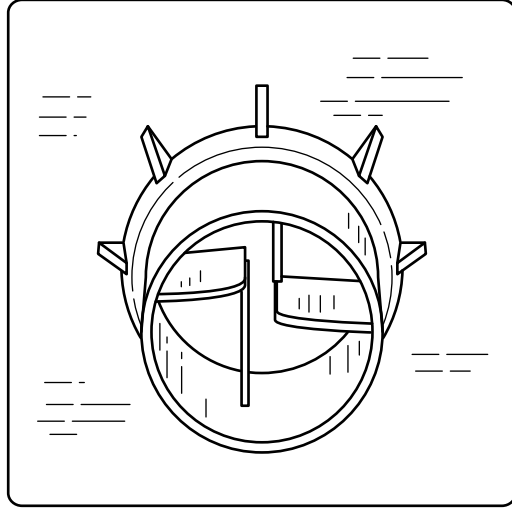

BEFORE

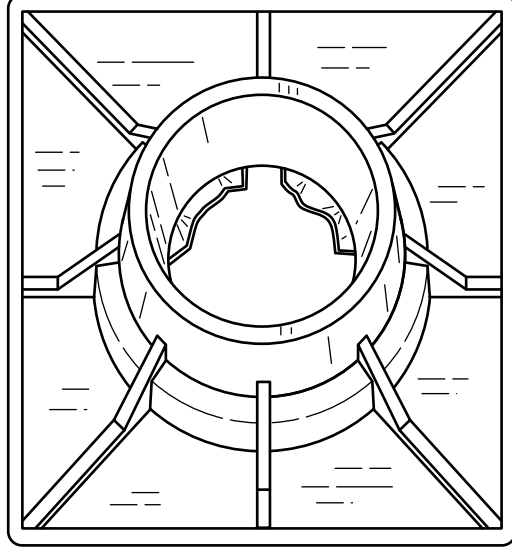

AFTER

1/5

FIG.1
PRIOR ART

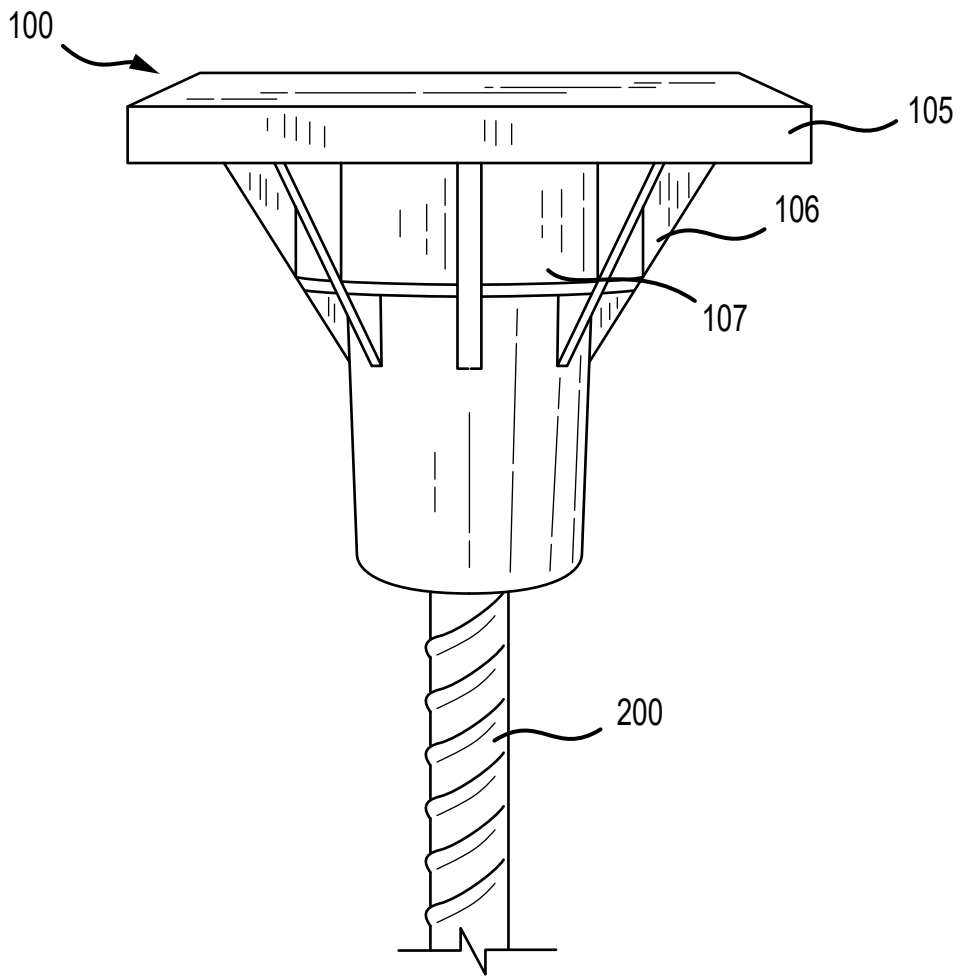

FIG.2

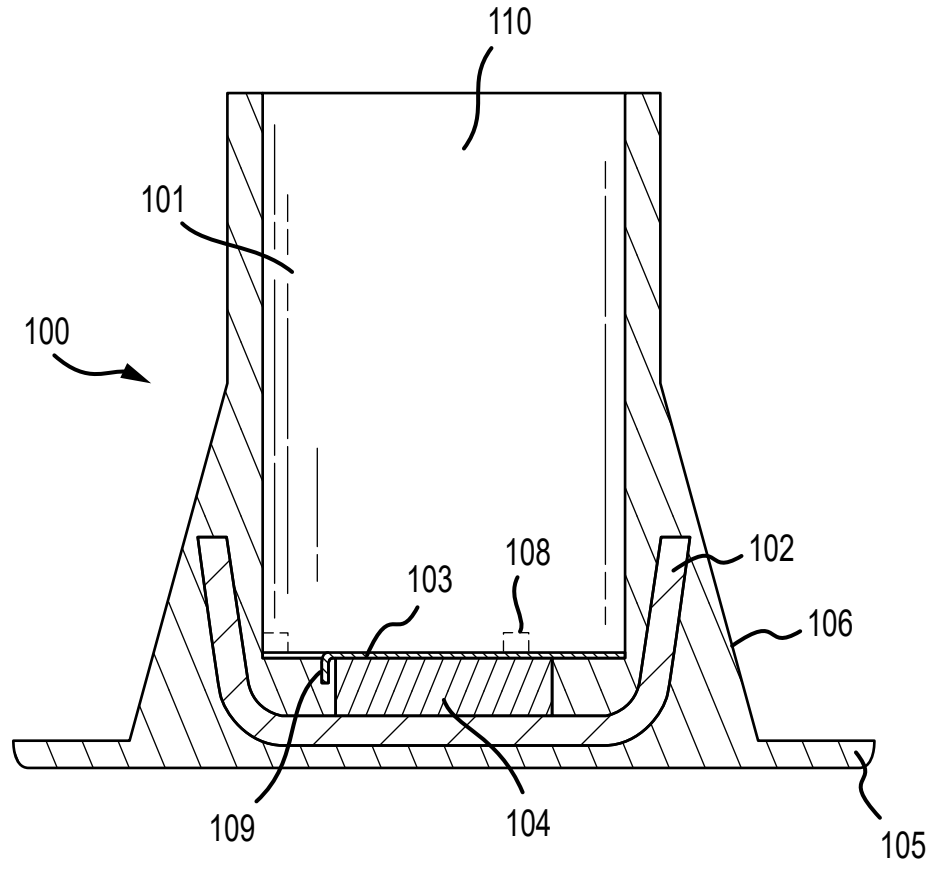

FIG.3

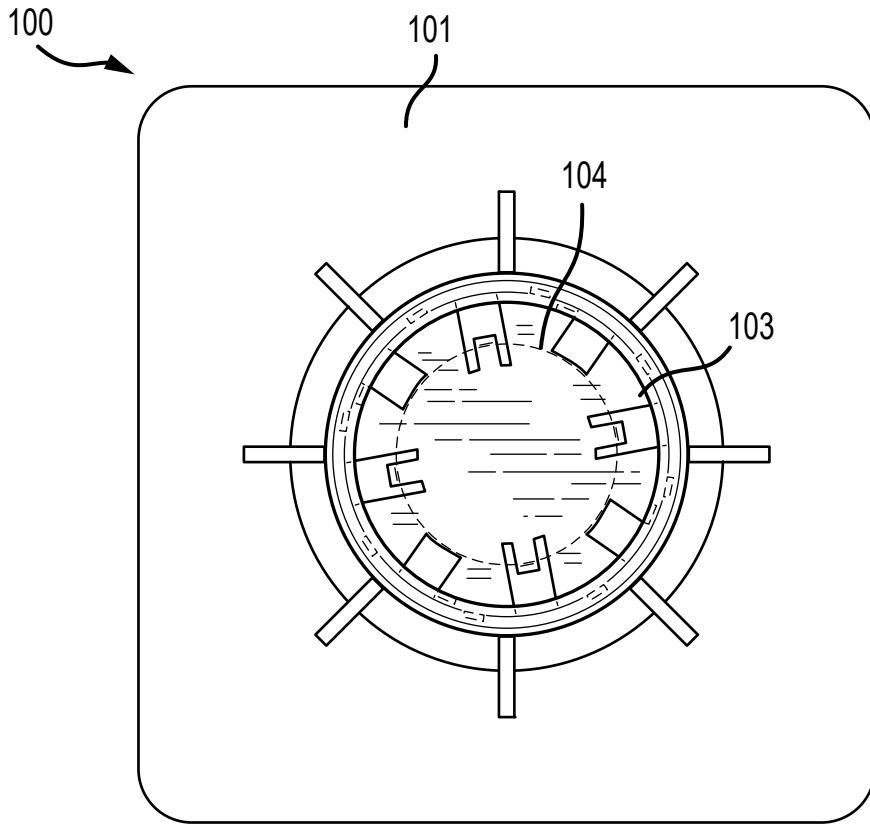

FIG.4

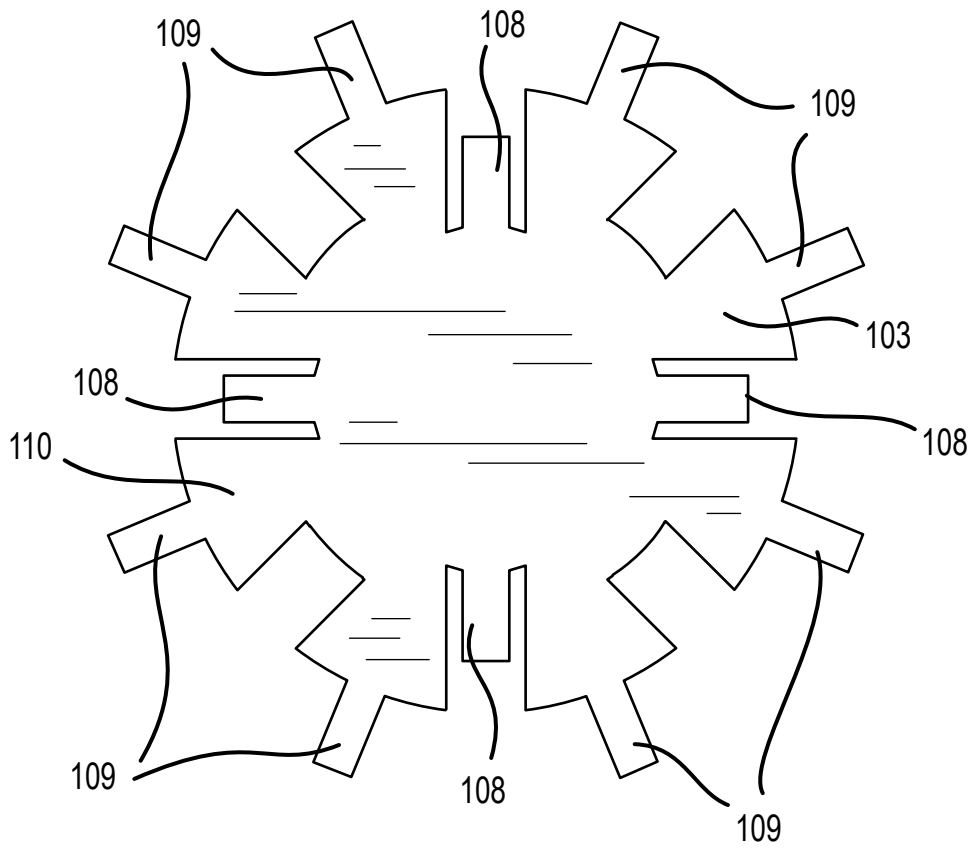

FIG.5