

(12) STANDARD PATENT APPLICATION (11) Application No. AU 2025226760 A1
(19) AUSTRALIAN PATENT OFFICE

(54) Title
A NOVEL EVAPORATOR STRUCTURE AND A BEVERAGE DISPENSER

(51) International Patent Classification(s)
F25B 39/02 (2006.01) **A23G 9/08** (2006.01)

(21) Application No: **2025226760** (22) Date of Filing: **2025.06.30**

(30) Priority Data

(31) Number	(32) Date	(33) Country
202422128042.5	2024.08.30	CN
202422188593.0	2024.09.06	CN

(43) Publication Date: **2026.03.19**

(43) Publication Journal Date: **2026.03.19**

(71) Applicant(s)
GUANGZHOU XIN'AN TRADING CO., LTD.

(72) Inventor(s)
ZHOU, Quan

(74) Agent / Attorney
PATENTS AU PTY LTD, 43 Bowen Street, Malvern East, VIC, 3145, AU

ABSTRACT

The present application provides an evaporator structure and a beverage dispenser. The evaporator structure comprises an evaporator shell and an evaporator tube wound on a side wall of the shell. A cross-section of the evaporator tube is composed of a contact portion and a smoothly extending portion, wherein the contact portion abuts against the side wall of the evaporator shell. Specifically, the contact portion's abutment against the shell wall increases the contact area between the refrigerant and the shell, thereby improving heat transfer efficiency. The smoothly extending portion allows for smoother refrigerant flow within the pipe, reducing turbulence and resistance. Due to the optimized tube shape, the evaporator tube more effectively transfers heat to the side wall of the shell during refrigeration, thus enhancing heat exchange and refrigeration efficiency. This effectively solves the problem of low efficiency in the prior art caused by a smaller contact area.

A NOVEL EVAPORATOR STRUCTURE AND A BEVERAGE DISPENSER

TECHNICAL FIELD

[0001] The present application relates to the technical field of evaporators, and more particularly, to a novel evaporator structure and a beverage dispenser.

BACKGROUND

[0002] The evaporator is an important component in a beverage dispenser and is a type of heat exchanger. A low-temperature condensed liquid passes through the evaporator and exchanges heat with the outside air, vaporizing and absorbing heat to achieve a refrigeration effect. Currently, the evaporators in most beverage dispensers (such as slushie machines, ice cream machines, ice makers, etc.) generally include an evaporator body and a coil pipe. The evaporator body includes inner and outer shells, and the coil pipe is sleeved on the inner shell and is in contact with the wall of the outer shell. A condensed liquid is passed through the coil pipe, and the condensed liquid performs heat exchange with the outside through the wall of the coil pipe and the wall of the outer shell of the evaporator body to achieve the refrigeration effect.

[0003] Chinese Patent Document No. CN204854082U, published in 2015, discloses an evaporator, which specifically includes a side cylinder, a top cover and a bottom cover respectively provided at the upper and lower ends of the side cylinder, a water flow outlet and a water flow inlet respectively provided on the top cover and the bottom cover, a refrigerant outlet, a refrigerant inlet, and a temperature sensing tube port also provided on the top cover, and a refrigerant titanium pipeline provided inside the side cylinder, wherein the inlet end and the outlet end of the refrigerant titanium pipeline are respectively connected to the refrigerant inlet and the refrigerant outlet, and the refrigerant titanium pipeline has a spiral coil structure. In the aforementioned published patent document, the contact area between the pipeline and the side cylinder is small, resulting in low heat exchange and refrigeration efficiency.

[0004] Therefore, there is a need for further improvement.

SUMMARY

[0005] In view of this, an object of the present application is to provide a novel evaporator structure and a beverage dispenser to overcome the deficiencies in the prior art,

by changing the shape of the evaporator tube to increase the contact area and improve heat exchange and refrigeration efficiency.

[0006] A novel evaporator structure designed to achieve this object comprises an evaporator shell and an evaporator tube, wherein the evaporator tube is wound on a side wall of the evaporator shell, a cross-section of the evaporator tube is composed of a contact portion and a smoothly extending portion, and the contact portion abuts against the side wall of the evaporator shell.

[0007] The evaporator tube is annularly coiled along a height direction of the evaporator shell.

[0008] The evaporator tube is circumferentially coiled along the side wall of the evaporator shell.

[0009] The smoothly extending portion is an arc-shaped surface, the contact portion is at least partially a linear surface or a quasi-linear surface, and the smoothly extending portion is connected to an end of the contact portion.

[0010] The contact portion includes two parallel linear surfaces or quasi-linear surfaces, the smoothly extending portion includes two arc-shaped surfaces, and two ends of each of the arc-shaped surfaces are respectively connected to same-side ends of the two linear surfaces or quasi-linear surfaces.

[0011] The evaporator tube abuts against the side wall of the evaporator shell in a multi-layered stacked manner.

[0012] The evaporator tube has a refrigerant inlet and a refrigerant outlet for refrigerant to enter and exit, and the refrigerant inlet and the refrigerant outlet are respectively located at opposite ends of the evaporator tube.

[0013] The evaporator tube further comprises an inlet transition tube and an inlet transition portion, wherein one end of the inlet transition portion is connected to the refrigerant inlet by welding or is integrally formed, and the inlet transition tube is connected to another end of the inlet transition portion;

[0014] a radial dimension of the inlet transition portion gradually increases from the inlet transition tube towards the refrigerant inlet;

[0015] the evaporator tube further comprises an outlet transition tube and an outlet transition portion, wherein one end of the outlet transition portion is connected to the refrigerant outlet by welding or is integrally formed, and the outlet transition portion is connected to another end of the outlet transition tube.

[0016] Center axes of the evaporator shell and the evaporator tube are arranged coaxially, and the evaporator tube abuts against an inner wall or an outer wall of the evaporator shell.

[0017] A beverage dispenser comprises the aforementioned novel evaporator structure.

[0018] In the a novel evaporator structure and a beverage dispenser of the above embodiments, the novel evaporator structure comprises an evaporator shell and an evaporator tube, the evaporator tube is wound on a side wall of the evaporator shell, a cross-section of the evaporator tube is composed of a contact portion and a smoothly extending portion, and the contact portion abuts against the side wall of the evaporator shell. Specifically, the contact portion abutting against the side wall of the evaporator shell increases the contact area between the refrigerant and the evaporator shell, thereby improving heat transfer efficiency; the provision of the smoothly extending portion allows the refrigerant to flow more smoothly within the pipe, reducing turbulence and resistance; due to the optimized shape of the evaporator tube, the evaporator tube can more effectively transfer heat to the side wall of the evaporator shell during the refrigeration process, thereby improving heat exchange and enhancing refrigeration efficiency; this effectively solves the problem of low heat exchange and refrigeration efficiency caused by a small contact area in the prior art.

BRIEF DESCRIPTION OF THE DRAWINGS

[0019] The accompanying drawings, which constitute a part of this application, are provided for a further understanding of the present application. The illustrative embodiments of the present application and their descriptions are used to explain the present application and do not constitute an undue limitation of the present application.

[0020] To more clearly illustrate the technical solutions in the embodiments of the present application, the accompanying drawings required for the description of the embodiments will be briefly introduced below. It is obvious that the drawings in the following description are only some embodiments of the present application, and for those of ordinary skill in the art, other drawings can be obtained based on these drawings without creative effort.

[0021] FIG. 1 is a schematic structural view of an evaporator according to a first embodiment of the present application.

[0022] FIG. 2 is a cross-sectional view of the overall structure of the evaporator according to the first embodiment of the present application.

[0023] FIG. 3 is an enlarged view of part A in FIG. 2.

[0024] FIG. 4 is an exploded view of the overall structure of the evaporator according to the first embodiment of the present application.

[0025] FIG. 5 is a schematic structural view of an evaporator tube according to the first embodiment of the present application.

[0026] FIG. 6 is a schematic structural view of the evaporator tube from another direction according to the first embodiment of the present application.

[0027] FIG. 7 is a cross-sectional view of the structure of the evaporator tube according to the first embodiment of the present application.

[0028] FIG. 8 is a cross-sectional view of the structure of the evaporator tube from another direction according to the first embodiment of the present application.

[0029] FIG. 9 to FIG. 11 are schematic views of the shape of the evaporator according to the first embodiment of the present application.

[0030] FIG. 12 is a schematic view of the circumferential structure of the evaporator tube coiled on the evaporator shell according to a second embodiment of the present application.

DETAILED DESCRIPTION

[0031] To make the aforementioned objects, features, and advantages of the present application more obvious and understandable, the specific embodiments of the present application will be described in detail below with reference to the accompanying drawings. In the following description, many specific details are set forth to provide a thorough understanding of the present application. However, the present application can be implemented in many other ways different from those described herein, and a person skilled in the art can make similar modifications without departing from the spirit of the present application. Therefore, the present application is not limited by the specific embodiments disclosed below.

[0032] As shown in FIG. 1 to FIG. 11, a novel evaporator structure and a beverage dispenser are provided. The novel evaporator structure comprises an evaporator shell 1 and an evaporator tube 2. The evaporator tube 2 is wound on a side wall of the evaporator shell 1. A cross-section of the evaporator tube 2 is composed of a contact portion 201 and a

smoothly extending portion 208, and the contact portion 201 abuts against the side wall of the evaporator shell 1.

[0033] Specifically, the contact portion 201 abutting against the side wall of the evaporator shell increases the contact area between the refrigerant and the evaporator shell 1, thereby improving heat transfer efficiency; the provision of the smoothly extending portion 208 allows the refrigerant to flow more smoothly within the pipe, reducing turbulence and resistance; due to the optimized shape of the evaporator tube 2, the evaporator tube 2 can more effectively transfer heat to the side wall of the evaporator shell 1 during the refrigeration process, thereby improving heat exchange and enhancing refrigeration efficiency; this effectively solves the problem of low heat exchange and refrigeration efficiency caused by a small contact area in the prior art.

[0034] Furthermore, as shown in FIG. 2, the evaporator tube 2 is annularly coiled along a height direction of the evaporator shell 1.

[0035] Specifically, the evaporator tube 2 being coiled along the height direction of the evaporator shell 1 allows the condensed liquid to flow for a long time within the evaporator tube and continuously perform heat exchange, allowing the condensed liquid to flow for a long time within the evaporator tube 2 and continuously perform heat exchange, thereby improving the refrigeration effect.

[0036] Furthermore, as shown in FIG. 3, the smoothly extending portion 208 is an arc-shaped surface 2081, the contact portion 201 is at least partially a linear surface 2011 or a quasi-linear surface, and the smoothly extending portion 208 is connected to an end of the contact portion 201.

[0037] Specifically, the smoothly extending portion 208 being an arc-shaped surface 2081 can effectively reduce the resistance of the refrigerant flow, allowing the refrigerant to flow more smoothly through the entire evaporator tube 2, thereby improving heat exchange efficiency; the design of the linear surface 2011 or quasi-linear surface of the contact portion 201 ensures that the contact area between the evaporator tube 2 and the evaporator shell 1 is maximized; the linear surface or quasi-linear surface can closely fit against the side wall of the evaporator shell 1, enhancing the heat transfer effect of the refrigerant and making the heat exchange more efficient.

[0038] It should be noted that a quasi-linear surface refers to a surface that is close to a straight line, and so on.

[0039] Furthermore, as shown in FIG. 9 to FIG. 11, the contact portion 201 includes two parallel linear surfaces 2011 or quasi-linear surfaces, the smoothly extending portion

208 includes two arc-shaped surfaces 2081, and two ends of each of the arc-shaped surfaces 2081 are respectively connected to same-side ends of the two linear surfaces 2011 or quasi-linear surfaces.

[0040] Specifically, as shown in FIG. 9, the evaporator tube 2 is formed into a flat tube shape by two arc-shaped surfaces 2081 and two parallel linear surfaces 2011, which can optimize the flow path, reduce turbulence, and increase the contact area with the evaporator shell; wherein, the two arc-shaped surfaces are respectively located on the upper and lower sides of the evaporator tube 2, forming smooth transition portions, while the two linear surfaces are located on the left and right sides, forming parallel straight edges; alternatively, the two arc-shaped surfaces are respectively located on the left and right sides of the evaporator tube 2, while the two linear surfaces are located on the upper and lower sides and connected to the two arc-shaped surfaces.

[0041] Alternatively, as shown in FIG. 10, the evaporator tube 2 is formed into a bowl shape by two arc-shaped surfaces 2081 and two parallel linear surfaces 2011, wherein the two arc-shaped surfaces are respectively located on the left and right sides of the evaporator tube 2, while the two linear surfaces are located on the upper and lower sides and connected to the two arc-shaped surfaces, and the length of the upper linear surface segment is shorter than the length of the lower linear surface.

[0042] Alternatively, as shown in FIG. 11, the evaporator tube 2 is formed into an elliptical shape by one arc-shaped surface 2081 and one parallel linear surface 2011. One arc-shaped surface 2081 forms a parabola and is connected to one parallel linear surface 2011, which reduces sharp corners, allowing fluid to flow more smoothly in the pipe, which helps to reduce turbulence and optimize the flow path of the refrigerant.

[0043] It should be noted that the shape of the evaporator tube 2 can be further optimized according to the specific needs of different refrigeration equipment.

[0044] Furthermore, as shown in FIG. 2 and FIG. 3, the evaporator tube 2 abuts against the side wall of the evaporator shell 1 in a multi-layered stacked manner.

[0045] Specifically, arranging the evaporator tube 2 in multiple layers on the side wall of the evaporator shell 1 significantly increases the contact area between the evaporator tube 2 and the evaporator shell 1; each layer of the evaporator tube 2 is in close contact with the evaporator shell 1, allowing the refrigerant to transfer heat at more contact points, thereby greatly improving the heat exchange efficiency of the system and making the temperature distribution of the entire evaporator more uniform, thus avoiding local

overcooling or overheating phenomena and improving the stability and efficiency of the refrigeration equipment.

[0046] Furthermore, as shown in FIG. 4 to FIG. 8, the evaporator tube 2 has a refrigerant inlet 202 and a refrigerant outlet 203 for the refrigerant to enter and exit, and the refrigerant inlet 202 and the refrigerant outlet 203 are respectively located at opposite ends of the evaporator tube 2.

[0047] Specifically, the refrigerant can flow smoothly through the evaporator tube 2 to complete the entire pipeline circulation; the refrigerant enters the evaporator tube 2 from the refrigerant inlet 202, continuously absorbs heat from within the evaporator shell 2 during the flow process, until the refrigerant reaches the other end of the evaporator tube 2, and is finally discharged from the refrigerant outlet 203; by providing the refrigerant inlet 202 and the refrigerant outlet 203 at opposite ends of the evaporator tube 2, the refrigerant can flow more uniformly within the evaporator tube 2.

[0048] Furthermore, as shown in FIG. 4 to FIG. 8, the evaporator tube 2 also comprises an inlet transition tube 204 and an inlet transition portion 205. One end of the inlet transition portion 205 is connected to the refrigerant inlet 202 by welding or is integrally formed, and the inlet transition tube 204 is connected to another end of the inlet transition portion 205.

[0049] As shown in FIG. 5, a radial dimension of the inlet transition portion 205 gradually increases from the inlet transition tube 204 towards the refrigerant inlet 202.

[0050] As shown in FIG. 6, the evaporator tube 2 also comprises an outlet transition tube 206 and an outlet transition portion 207. One end of the outlet transition portion 207 is connected to the refrigerant outlet 203 by welding or is integrally formed, and the outlet transition portion 207 is connected to another end of the outlet transition tube 206.

[0051] Specifically, the provision of the inlet transition tube 204 and the inlet transition portion 205 can effectively guide the refrigerant to flow into the interior of the evaporator tube 2; the inlet transition portion 205 is connected to the refrigerant inlet 202 by welding or is integrally formed, ensuring good sealing and stable mechanical structure during the refrigerant introduction process.

[0052] The gradually increasing radial dimension of the inlet transition portion 205 causes the flow cross-section to gradually increase as the refrigerant flows from the inlet transition tube 204 into the refrigerant inlet 202, effectively reducing the pressure loss of the refrigerant flow, mitigating flow resistance, and allowing the refrigerant to enter the interior of the evaporator tube 2 more smoothly.

[0053] By providing the outlet transition tube 206 and the outlet transition portion 207, the refrigerant can be discharged more smoothly from the evaporator tube 2 after completing the heat exchange; the outlet transition portion 207 is connected to the refrigerant outlet 203 by welding or is integrally formed, ensuring sealing and stability when the refrigerant is discharged.

[0054] Furthermore, as shown in FIG. 2 and FIG. 4, the center axes of the evaporator shell 1 and the evaporator tube 2 are arranged coaxially, and the evaporator tube 2 abuts against an inner wall or an outer wall of the evaporator shell 1.

[0055] Specifically, the coaxial arrangement of their center axes allows the evaporator tube 2 to be uniformly distributed around the evaporator shell 1, and allows the evaporator tube 2 to closely fit the evaporator shell 1, thereby significantly optimizing the structural symmetry and compactness of the entire evaporator; wherein, when the evaporator tube 2 is arranged on the inner wall of the evaporator shell 1, it can absorb and transfer heat more quickly; alternatively, when the evaporator tube 2 is arranged on the outer wall of the evaporator shell 1, the direct heat exchange between the refrigerant and the external environment is more effective.

[0056] A beverage dispenser comprises the aforementioned novel evaporator structure.

[0057] Specifically, the beverage dispenser integrates the novel evaporator structure, such that refrigerant enters from the refrigerant inlet 202, undergoes multi-layered heat exchange inside the evaporator tube 2, and is finally discharged from the refrigerant outlet 203. As the refrigerant flows within the evaporator tube 2, because its heat exchange area is greatly increased, the heat from the refrigerant is transferred to the side wall of the evaporator shell 1 through the evaporator tube 2, achieving efficient refrigeration.

[0058] In a second embodiment, as shown in FIG. 12, the novel evaporator structure and beverage dispenser of the present application differs from the first embodiment in that:

[0059] The evaporator tube 2 is circumferentially coiled along the side wall of the evaporator shell 1.

[0060] Specifically, a plurality of evaporator tubes 2 are vertically coiled in a circumferential direction along the side wall of the evaporator shell 1, and the connection points between two adjacent vertically coiled evaporator tubes 2 are connected by a smooth transition or a rounded transition; this allows the evaporator tube 2 to be uniformly distributed on the circumferential surface of the evaporator shell 1; this greatly increases the

contact area between the evaporator tube 2 and the evaporator shell 1, thereby increasing the heat exchange area between the refrigerant and the evaporator shell 1.

[0061] In the description of the present application, it is to be understood that terms such as “center,” “longitudinal,” “lateral,” “length,” “width,” “thickness,” “upper,” “lower,” “front,” “rear,” “left,” “right,” “vertical,” “horizontal,” “top,” “bottom,” “inner,” “outer,” “clockwise,” “counterclockwise,” “axial,” “radial,” “circumferential,” etc., indicate orientations or positional relationships based on the orientations or positional relationships shown in the drawings, and are merely for the convenience of describing the present application and simplifying the description, rather than indicating or implying that the apparatus or element referred to must have a particular orientation or be constructed and operated in a particular orientation, and therefore cannot be construed as a limitation on the present application.

[0062] Furthermore, the terms “first” and “second” are used for descriptive purposes only and cannot be understood as indicating or implying relative importance or implicitly indicating the number of technical features indicated. Thus, a feature defined with “first” or “second” may explicitly or implicitly include at least one such feature. In the description of the present application, “a plurality of” means at least two, such as two, three, etc., unless otherwise specifically defined.

[0063] In the present application, unless otherwise explicitly specified and limited, the terms “install,” “interconnect,” “connect,” “fix,” etc., should be understood in a broad sense. For example, it can be a fixed connection, a detachable connection, or an integral part; it can be a mechanical connection or an electrical connection; it can be a direct connection or an indirect connection through an intermediary, and it can be the communication within two elements or the interaction between two elements, unless otherwise explicitly limited. For a person of ordinary skill in the art, the specific meaning of the above terms in the present application can be understood according to the specific situation.

[0064] In the present application, unless otherwise explicitly specified and limited, a first feature being “on” or “under” a second feature may mean that the first and second features are in direct contact, or that the first and second features are in indirect contact through an intermediary. Moreover, a first feature being “above,” “over,” and “on top of” a second feature may mean that the first feature is directly above or obliquely above the second feature, or simply indicates that the horizontal level of the first feature is higher than that of the second feature. A first feature being “below,” “under,” and “beneath” a second

feature may mean that the first feature is directly below or obliquely below the second feature, or simply indicates that the horizontal level of the first feature is lower than that of the second feature.

[0065] It should be noted that when an element is referred to as being “fixed to” or “disposed on” another element, it can be directly on the other element or intervening elements may also be present. When an element is considered to be “connected” to another element, it can be directly connected to the other element or intervening elements may be simultaneously present. The terms “vertical,” “horizontal,” “upper,” “lower,” “left,” “right,” and similar expressions used herein are for illustrative purposes only and do not represent the only embodiment.

[0066] It should also be understood that in interpreting the connection or positional relationship of elements, although not explicitly described, the connection and positional relationships are interpreted to include an error range, which should be within an acceptable deviation determined by a person skilled in the art for a specific value. For example, “about,” “approximately,” or “substantially” may mean within one or more standard deviations, and is not limited herein.

[0067] The various technical features of the above embodiments can be combined in any way. To make the description concise, not all possible combinations of the various technical features in the above embodiments have been described. However, as long as there is no contradiction in the combination of these technical features, they should be considered to be within the scope of this specification.

[0068] The above embodiments only express several implementation manners of the present application, and their description is relatively specific and detailed, but they cannot therefore be understood as a limitation on the scope of the application patent. It should be pointed out that for a person of ordinary skill in the art, several variations and improvements can be made without departing from the concept of the present application, and these all belong to the protection scope of the present application. Therefore, the protection scope of the patent of the present application shall be subject to the appended claims.

CLAIMS

1. An evaporator structure, comprising:

an evaporator shell (1) and an evaporator tube (2), wherein the evaporator tube (2) is wound on a side wall of the evaporator shell (1), a cross-section of the evaporator tube (2) is composed of a contact portion (201) and a smoothly extending portion (208), and the contact portion (201) abuts against the side wall of the evaporator shell (1).

2. The evaporator structure according to claim 1, wherein: the evaporator tube (2) is annularly coiled along a height direction of the evaporator shell (1).

3. The evaporator structure according to claim 1, wherein: the evaporator tube (2) is circumferentially coiled along the side wall of the evaporator shell (1).

4. The evaporator structure according to any one of claims 1-3, wherein: the smoothly extending portion (208) is an arc-shaped surface (2081), the contact portion (201) is at least partially a linear surface (2011) or a quasi-linear surface, and the smoothly extending portion (208) is connected to an end of the contact portion (201).

5. The evaporator structure according to claim 4, wherein: the contact portion (201) comprises two parallel said linear surfaces (2011) or said quasi-linear surfaces, the smoothly extending portion (208) comprises two said arc-shaped surfaces (2081), and two ends of each of the arc-shaped surfaces (2081) are respectively connected to same-side ends of the two linear surfaces (2011) or the quasi-linear surfaces.

6. The evaporator structure according to claim 1, wherein: the evaporator tube (2) abuts against the side wall of the evaporator shell (1) in a multi-layered stacked manner.

7. The evaporator structure according to any one of claims 1-3, wherein: the evaporator tube (2) has a refrigerant inlet (202) and a refrigerant outlet (203) for refrigerant to enter and exit, and the refrigerant inlet (202) and the refrigerant outlet (203) are respectively located at opposite ends of the evaporator tube (2).

8. The evaporator structure according to claim 7, wherein: the evaporator tube (2) further comprises an inlet transition tube (204) and an inlet transition portion (205), wherein one end of the inlet transition portion (205) is connected to the refrigerant inlet (202) by welding or is integrally formed, and the inlet transition tube (204) is connected to another end of the inlet transition portion (205);

a radial dimension of the inlet transition portion (205) gradually increases from the inlet transition tube (204) towards the refrigerant inlet (202); and

the evaporator tube (2) further comprises an outlet transition tube (206) and an outlet transition portion (207), wherein one end of the outlet transition portion (207) is connected to the refrigerant outlet (203) by welding or is integrally formed, and another end of the outlet transition portion (207) is connected to the outlet transition tube (206).

9. The evaporator structure according to claim 1, wherein: center axes of the evaporator shell (1) and the evaporator tube (2) are arranged coaxially, and the evaporator tube (2) abuts against an inner wall or an outer wall of the evaporator shell (1).

10. A beverage dispenser, comprising: the evaporator structure according to any one of claims 1-9.

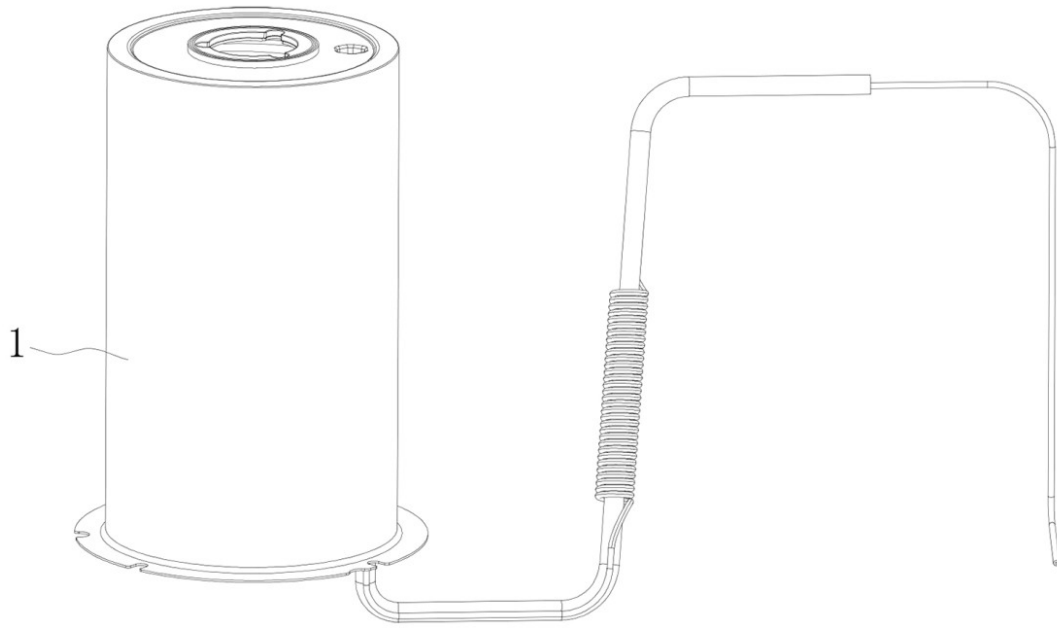

FIG. 1

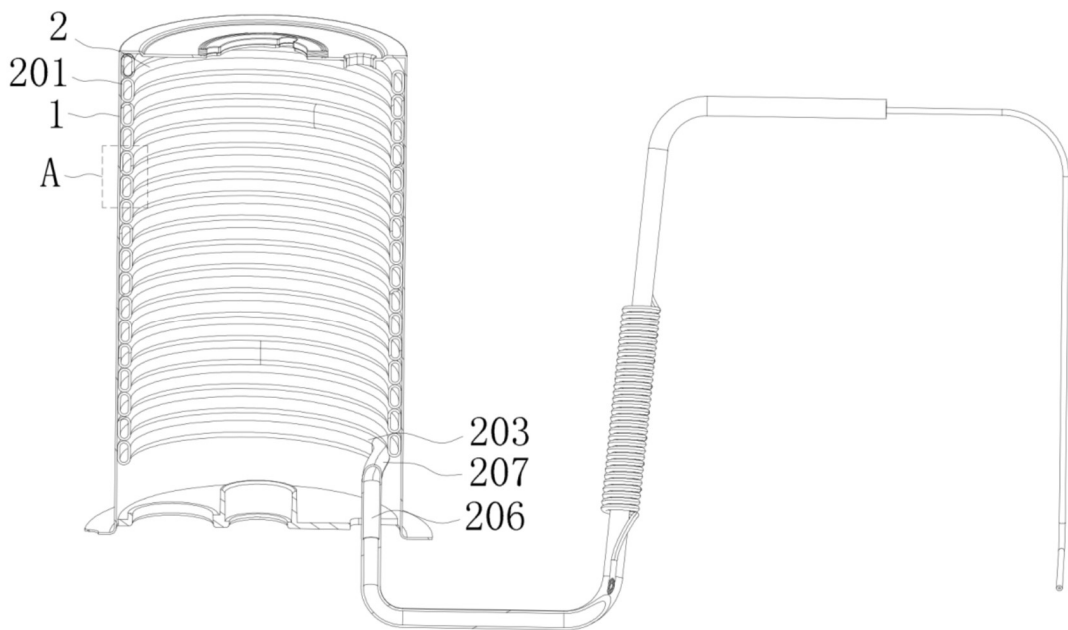

FIG. 2

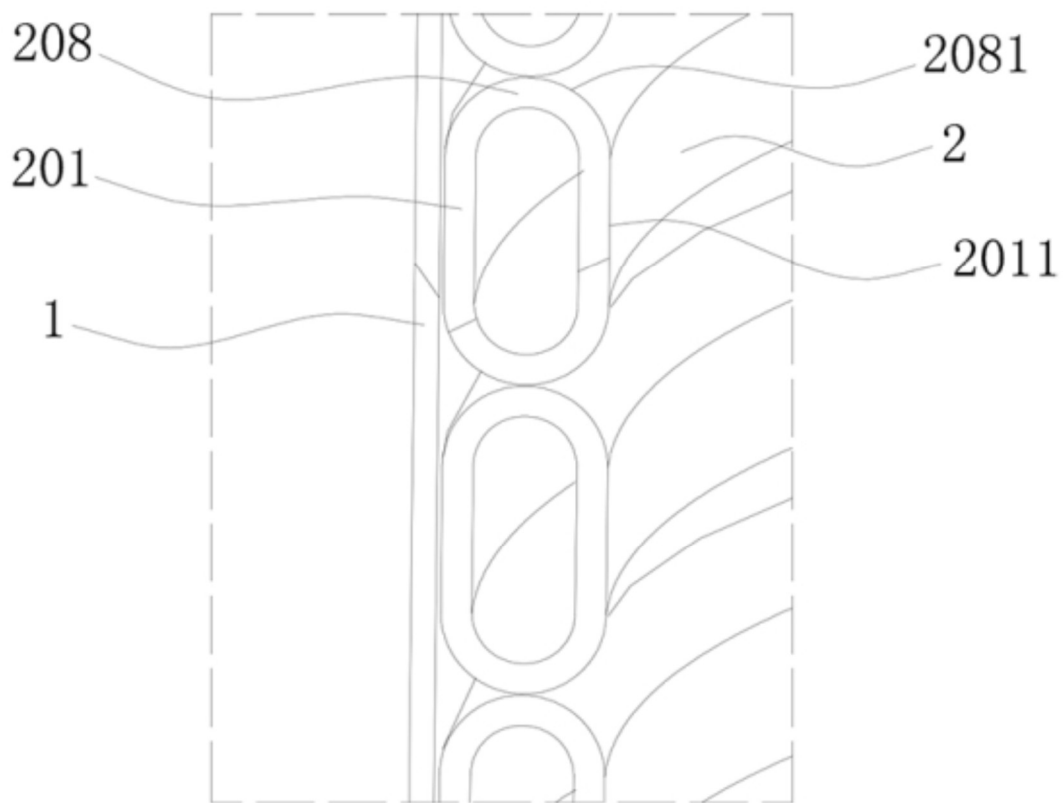

FIG. 3

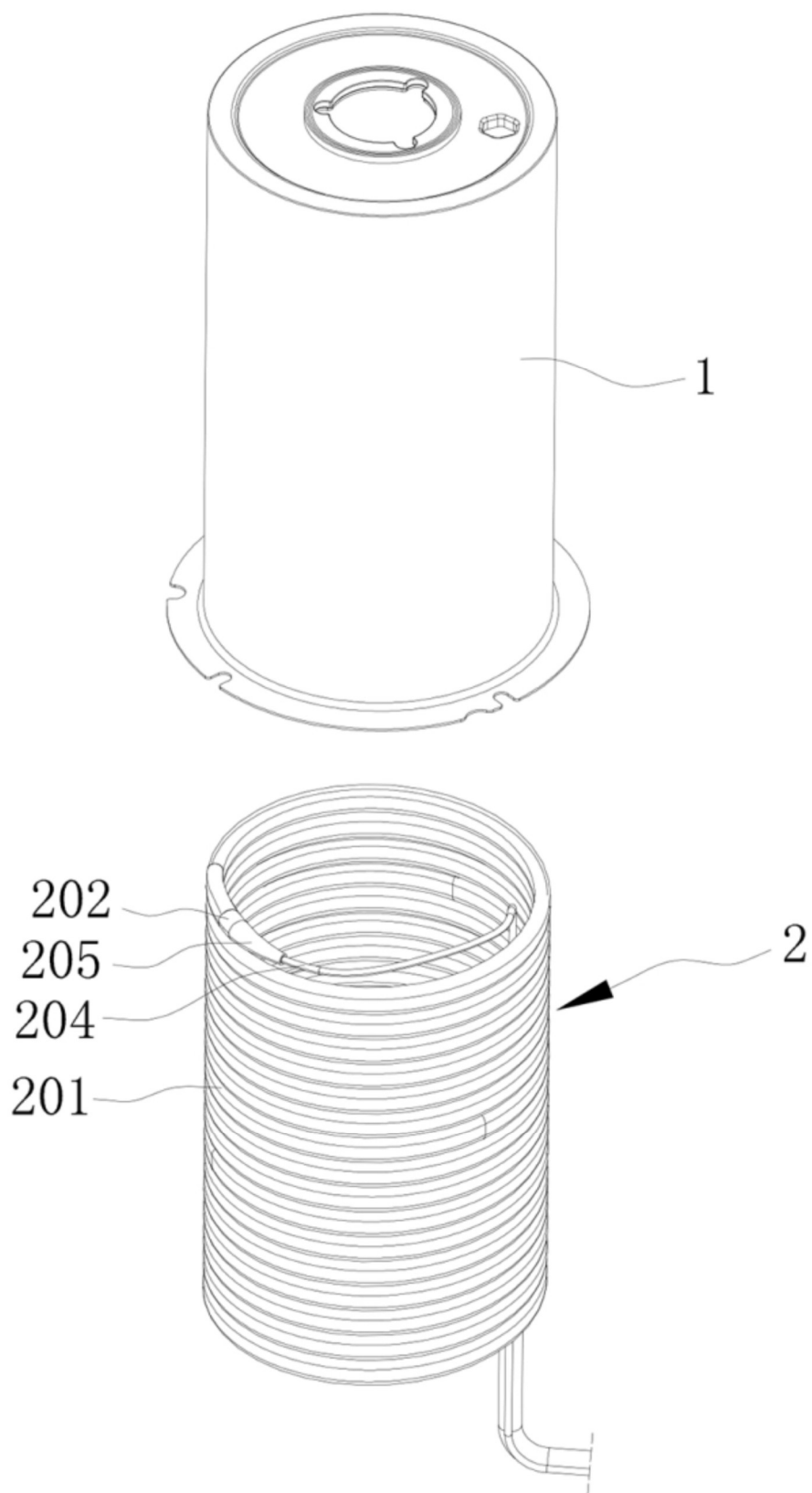

FIG. 4

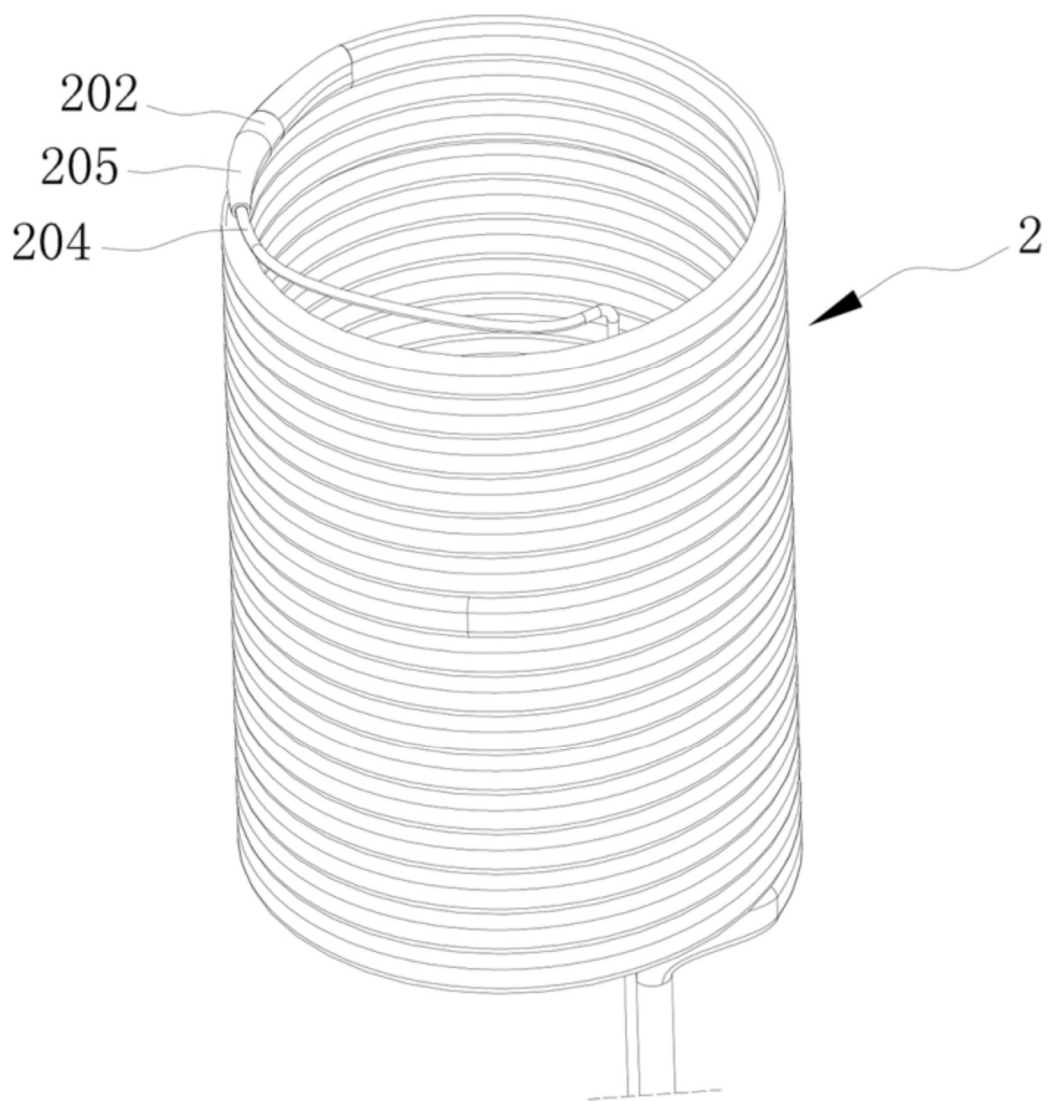

FIG. 5

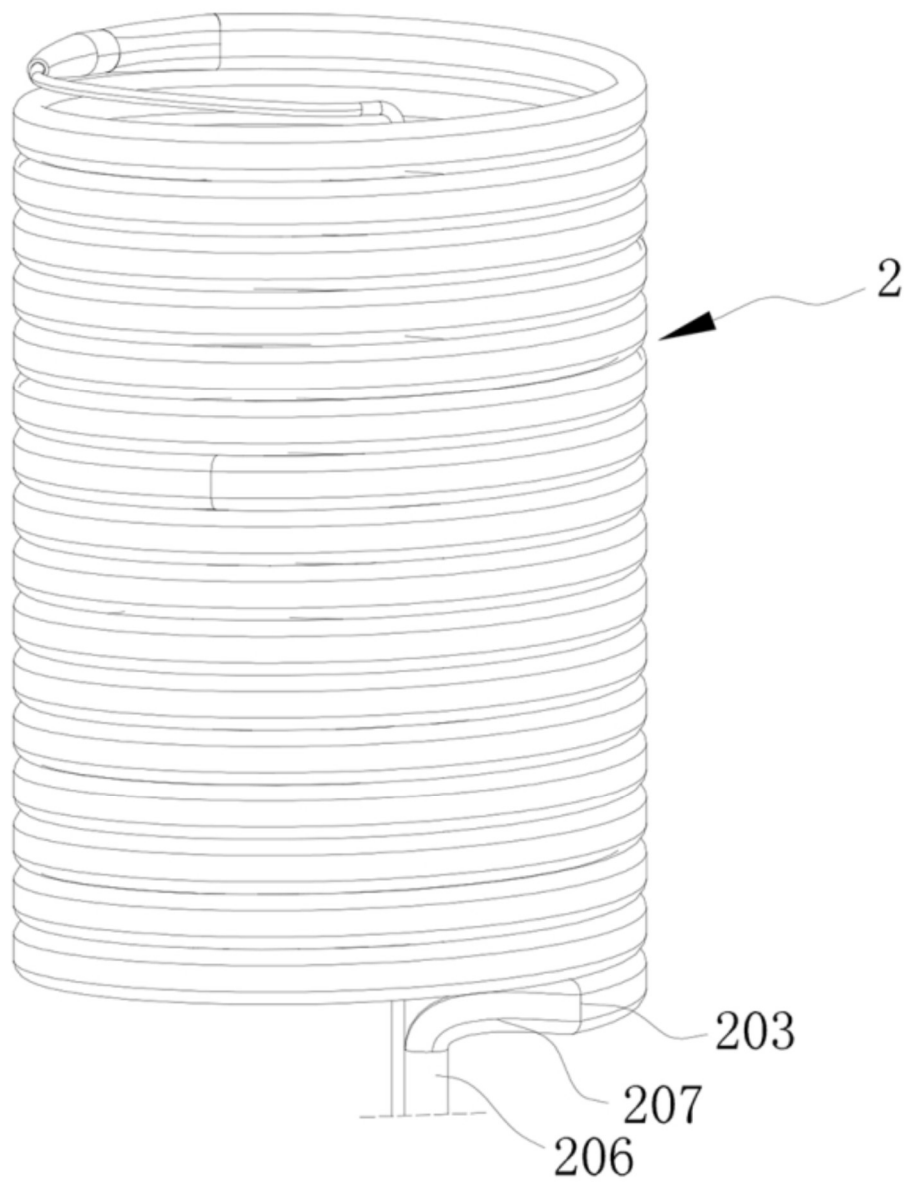

FIG. 6

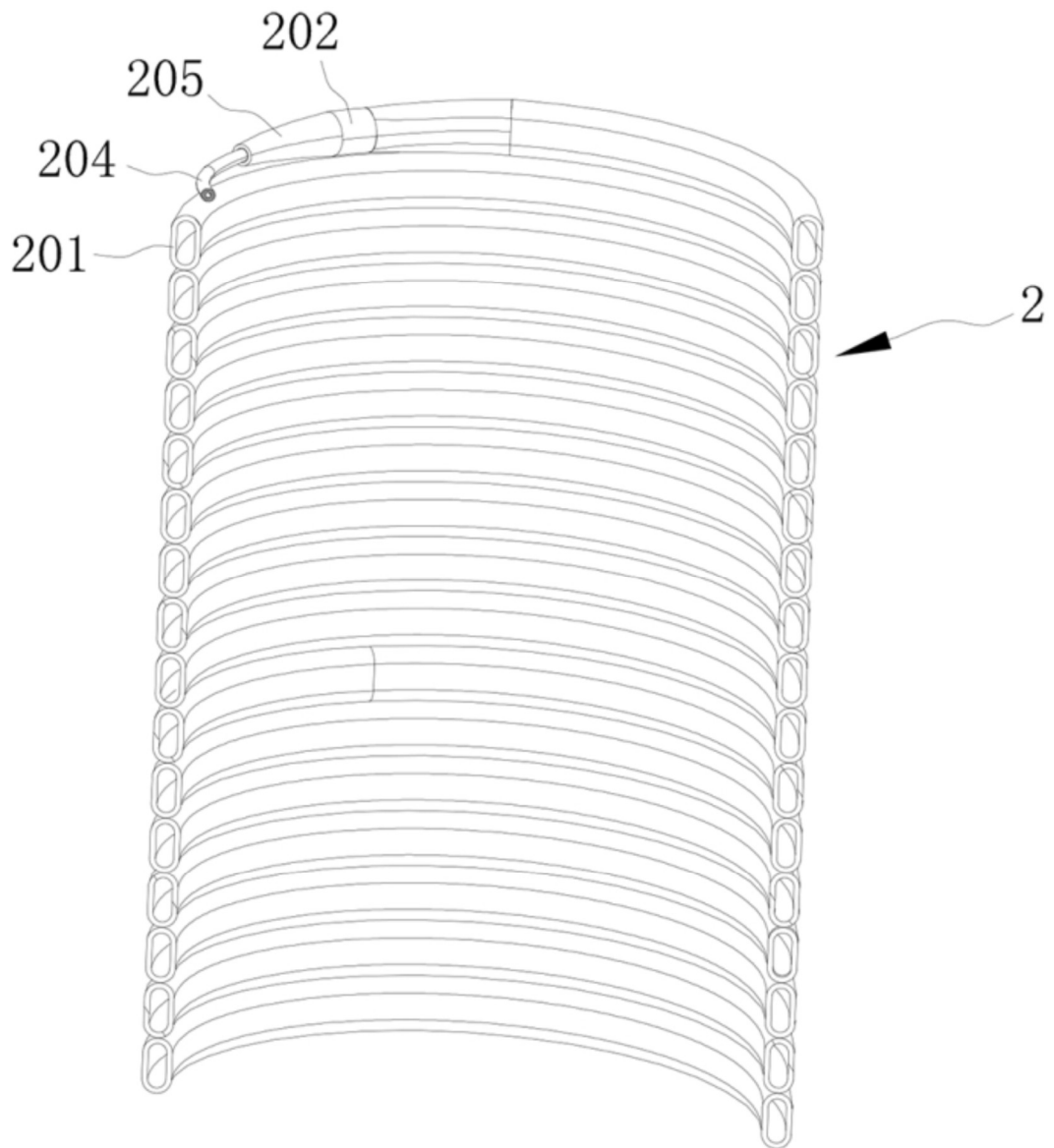

FIG. 7

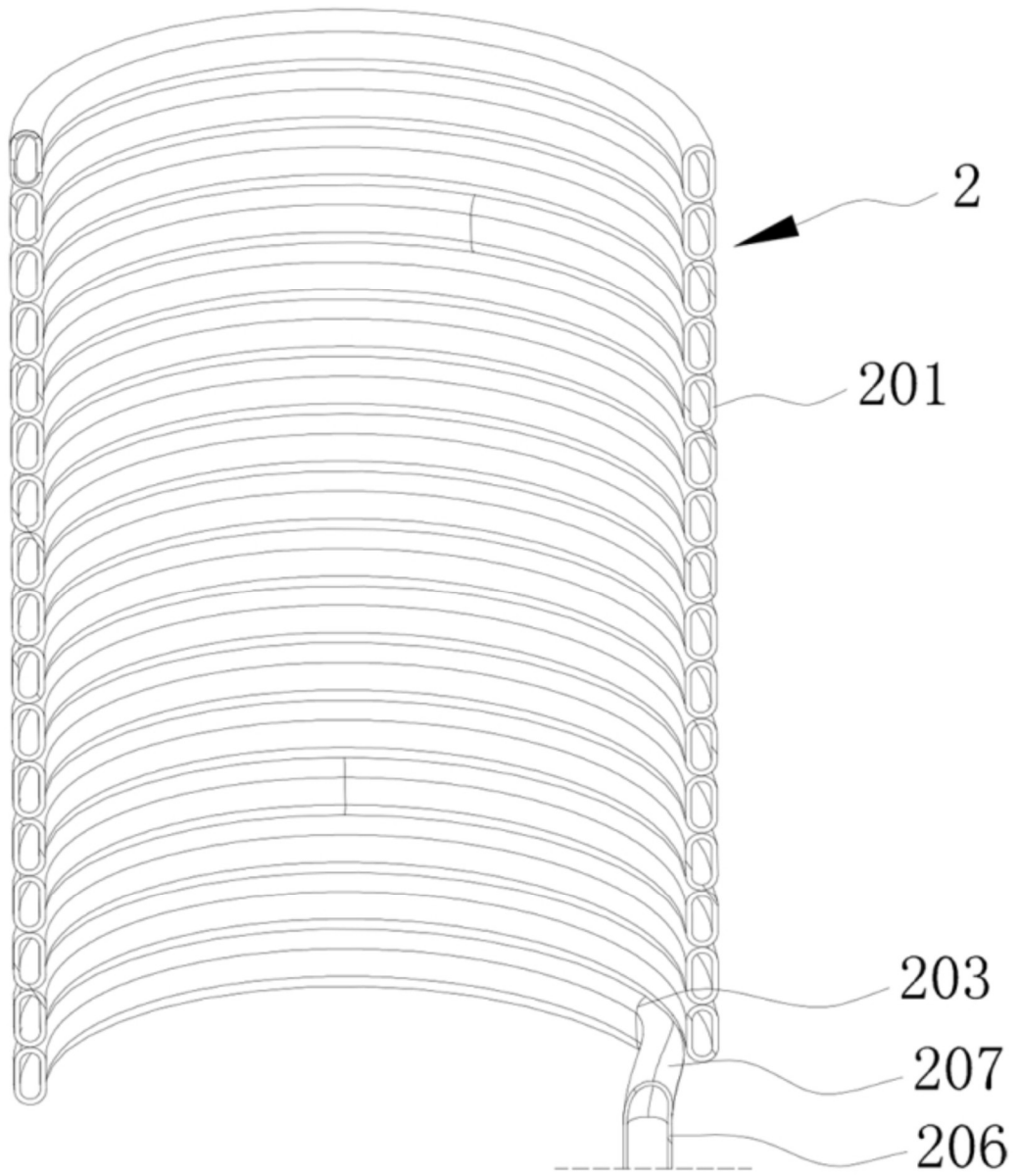

FIG. 8

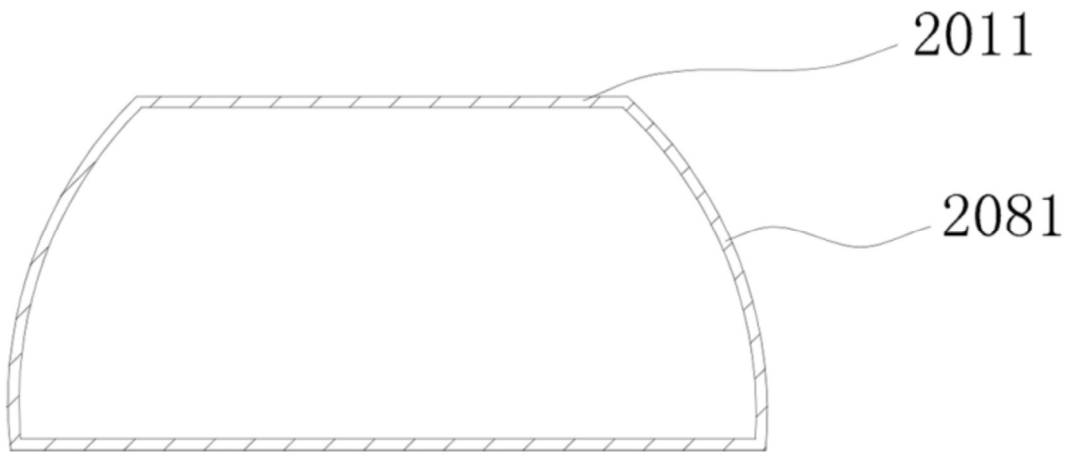

FIG. 9



FIG. 10

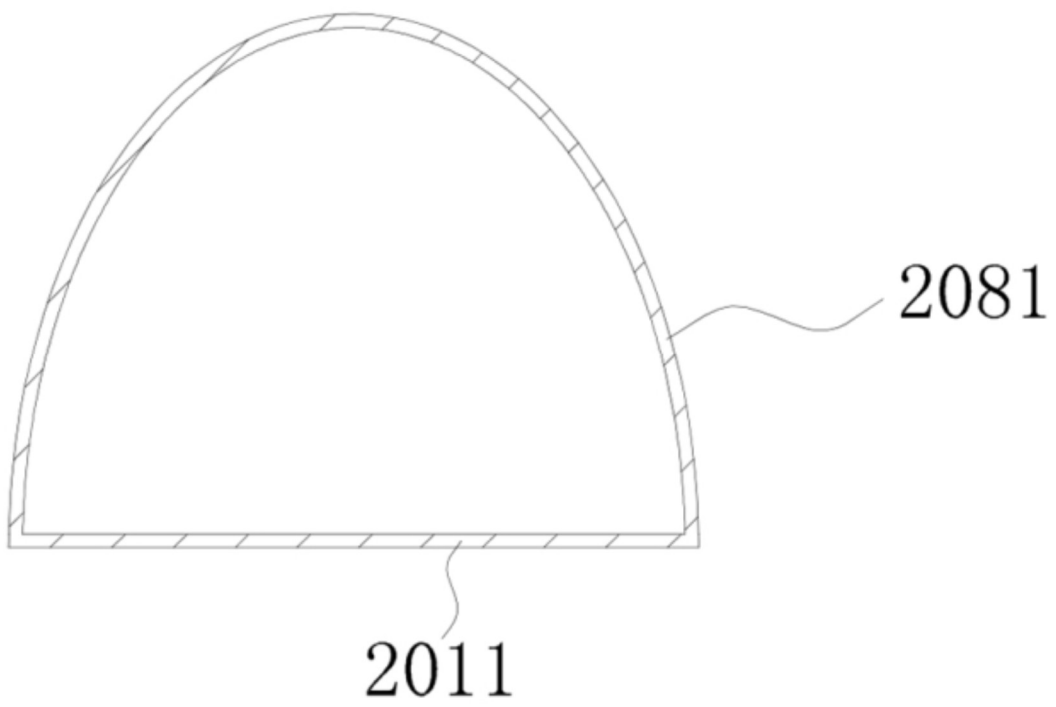

FIG. 11

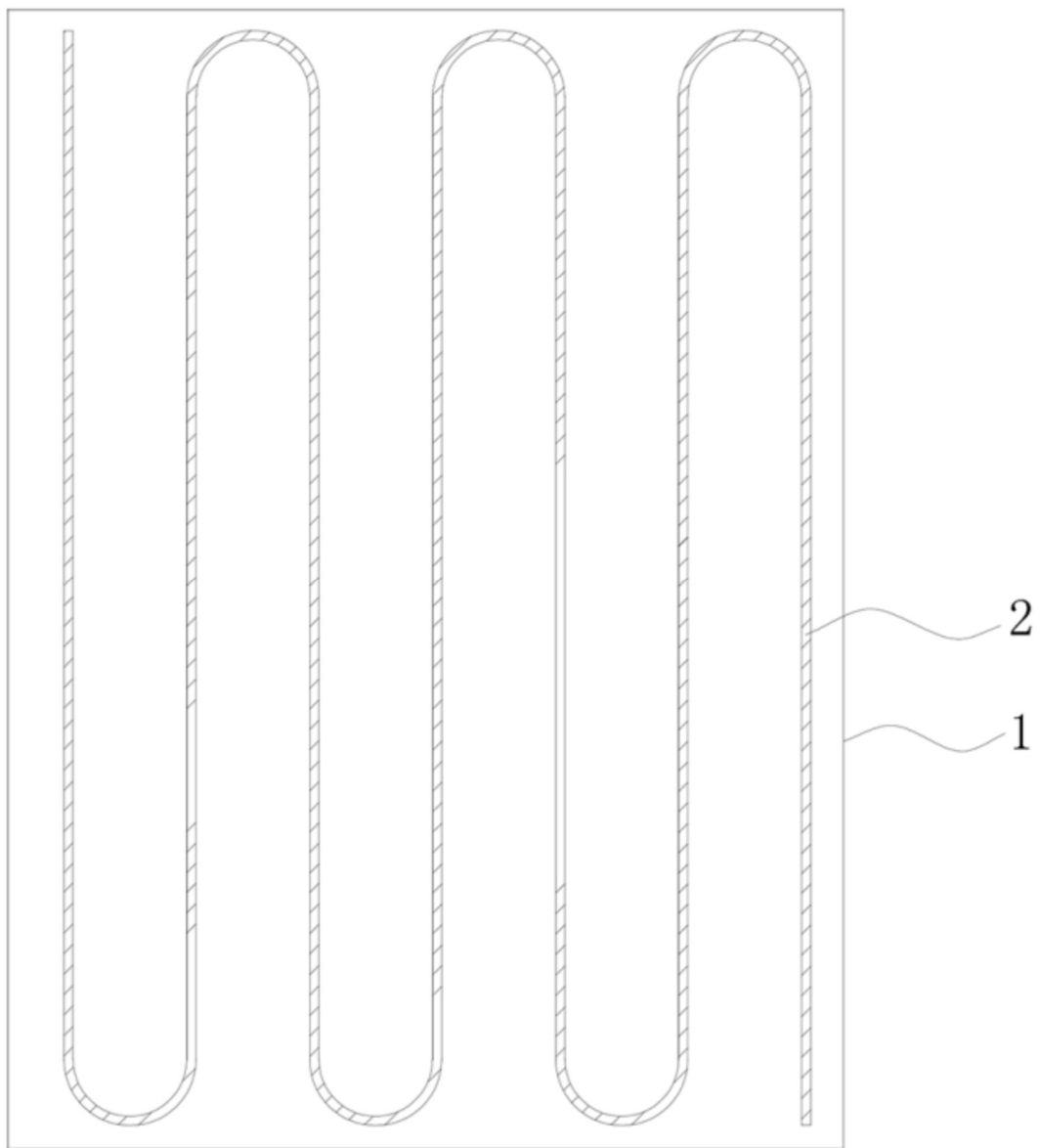

FIG. 12