

(12) STANDARD PATENT APPLICATION (11) Application No. AU 2026201199 A1
(19) AUSTRALIAN PATENT OFFICE

(54) Title
Polymer bracket

(51) International Patent Classification(s)
F16L 3/223 (2006.01)

(21) Application No: **2026201199** (22) Date of Filing: **2026.02.18**

(43) Publication Date: **2026.03.19**

(43) Publication Journal Date: **2026.03.19**

(62) Divisional of:
2024200351

(71) Applicant(s)
Michael Ferman

(72) Inventor(s)
Ferman, Michael

(74) Agent / Attorney
IP SOLVED (ANZ) PTY. LTD., PO BOX R1791, ROYAL EXCHANGE, NSW, 1225, AU

2026201199 18 Feb 2026

ABSTRACT

A bracket including: an elongate upper surface for providing support to an object, the upper surface having a first end and a second end; a mounting element is located about the first end of the upper surface; the mounting element extends beneath, and substantially perpendicular to, the upper surface; a pair of brace elements extend beneath the upper surface to a lower portion of the mounting element.

POLYMER BRACKET

FIELD OF THE TECHNOLOGY

The technology relates to brackets, and more particularly to a polymer bracket.

BACKGROUND OF THE INVENTION

5 Any discussion of the prior art throughout the specification should in no way be considered as an admission that such prior art is widely known or forms part of the common general knowledge in the field.

In below ground and above ground uses, wall mounted brackets are used to support pipes, electrical lines, optical fibres and the like. A polymer wall mounted bracket has
10 the advantage of being resistant to corrosion, light weight and non-conductive.

OBJECTS THE TECHNOLOGY

It is an object of the present invention to overcome or ameliorate at least one of the disadvantages of the prior art, or to provide a useful alternative.

It is an object of the technology in a preferred form to provide a polymer bracket.

SUMMARY OF THE TECHNOLOGY

15 According to an aspect of the technology, there is provided a bracket, the bracket including:

an elongate upper surface for providing support to an object, the upper surface having a first end and a second end;

a mounting element is located about the first end of the upper surface; the mounting element extends beneath, and substantially perpendicular to, the upper surface;

a pair of brace elements extend beneath the upper surface to a lower portion of the mounting element.

Preferably, the bracket is a polymer bracket, or comprised primarily of a polymeric material. The polymer is preferably resilient and/or rigid and/or fire resistant. Most preferably, the bracket is integrally formed.

Preferably, the upper surface is perforated. More preferably, the upper surface defines an elongated rectangle having an array of through slots that are formed along the upper surface.

Preferably, the upper surface has side edges that each form an overhanging lip.

Preferably, the pair of brace elements are each in the form for a triangular side element. More preferably the triangular side elements are spaced apart and substantially parallel.

Preferably a triangular side element are perforated with an array of circular openings. More preferably, a long edge of each triangular side element is reinforced with an integral stiffening rib. Typically, the long edge extends between the mounting element and the underside of the upper surface about its distal tip at the second end. Most preferably, the long edge also defines a bead for forming a channel between the bead and the stiffening rib.

Alternatively, the pair of brace elements are each preferably in the form for a bracing arm. More preferably the bracing arms are spaced apart and substantially parallel.

Typically, the bracing arm extends between the mounting element and the underside of the upper surface about its distal tip at the second end. More preferably, each bracing arm is reinforced with an integral stiffening rib. Most preferably, each bracing arm also defines a bead for forming a channel between the bead and the stiffening rib.

Preferably, the mounting element extends from the lower portion of the bracing elements to a location vertically above the upper surface. More preferably, the mounting element forms an extension above the level of the upper surface through which is formed an uppermost mounting through hole. Most preferably, one or more mounting openings are located in mounting element that can be accessed between the bracing elements.

BRIEF DESCRIPTION OF THE DRAWING FIGURES

In order that the invention be better understood, reference is now made to the following drawing figures in which:

FIG. 1 is prospective view of a polymer bracket;

FIG. 2 is rear prospective view of a polymer bracket;

FIG. 3 is a side view of a polymer bracket;

FIG. 4 is a front view of a polymer bracket; and

FIG. 5 is a prospective view of another embodiment of a polymer bracket.

BEST MODE AND OTHER EMBODIMENTS

As shown in FIG. 1, a polymeric wall bracket 100 has an upper surface 101 for supporting pipes, lines, wires, cables and the like. The polymer is preferably resilient, rigid, fire resistant and safe for use in hazardous environments and enclosed spaces. In this example, the upper surface 101 forms an elongated rectangle having an array of through slots 102 aligned along a longitudinal centre line of the upper surface. In this example there are four equally spaced slots. The slots may be used to retain fasteners, fixtures or accessories that compliment the utility of the bracket. The upper surface forms an overhanging lip 103 with respect to the integral sides 104. In the example of FIG. 1, each of the two sides is triangular and perforated with an array of three circular openings 105 of different sizes. The openings 105 increase the versatility of uses that the bracket may be applied to and reduce weight. In this example, each side is triangular and the long side of the triangle is reinforced with an integral stiffening rib 106. The long edge of the triangular side also features a bead 107 along the long edge, forming a channel 108 between the bead or lip 107 and the stiffening rib 106. In this example, the long edge of the triangle 109 extends between an integral mounting plate 110 and the underside of the upper surface at its distal tip 111.

The backing plate portion or mounting “plate” 110 extends from the lower corner of the long edge 112 to a location 113 vertically above the upper surface 101. Thus, the plate forms an extension 114 above the level of the upper surface through which may be located an uppermost mounting through hole 115. Although the sides are conceptually connected at their upper extremes by the upper surface 101 and across their rear edges by the backing plate, the long edges 109 of the sides are not interconnected. Thus, the bracket forms a channel having an open bottom through

which the interior and any mounting openings or features located in the interior can be easily accessed.

As shown in FIG. 2, the plate portion 110 comprises a perimeter 200 that is subdivided by stiffening ribs 201. In this example, the plate provides two through mounting openings 115, 202, each opening rigidised by radially extending ribs 203. From FIG. 2 it can be seen that the rigidising rib 106 extends from the plate 110 to a location 204 adjacent to the upper surface 101.

As shown in FIG. 3, the overhanging lip 103 provides an underside 301 that can be engaged by clamps and other mounting fixtures. In preferred embodiments, the upper surface 101 is perpendicular to the rear surface 302 of the plate or plate portion 110.

FIG. 4 illustrates a front view of the bracket depicted in FIG. 1. Because there is no material connecting the long edges of the triangular sides, the interior forms an open sided interior compartment 400. Thus, the interior compartment 400 can be accessed through the open long side, through the circular or other openings 105 and through the slots 102. A mounting hole 401 located in the compartment and below the upper surface 101. Because one of the mounting openings 115 is external to the compartment 400, it is easier to mount the bracket than when the only mounting openings are below the upper surface or within the interior compartment of a double sided bracket.

In the example of FIG. 5, instead of having triangular and reinforcing sides, the bracket may be provided with fully open sides 500. In this example, the upper surface 101 and its lip 103 may be supported by a relatively narrow and integral brace 501 on each side. In this example, the braces comprises a channel 502 defined by

two ribs 503, 504, that form between them, a channel 505. This style of bracket provides the maximum accessibility through the open sides. It will be understood that the through opening between the upper surface, brace and plate 110 can be subdivided, reinforced and utilised in a number of ways.

5 Although the invention has been described with reference to specific examples, it will be appreciated by those skilled in the art that the invention may be embodied in many other forms.

As used herein, unless otherwise specified, the use of the ordinal adjectives "first", "second", "third", etc., to describe a common object, merely indicate that different
10 instances of like objects are being referred to, and are not intended to imply that the objects so described must be in a given sequence, either temporally, spatially, in ranking, or in any other manner.

Reference throughout this specification to "one embodiment" or "an embodiment" or "example" means that a particular feature, structure or characteristic described in
15 connection with the embodiment is included in at least one embodiment of the present invention. Thus, appearances of the phrases "in one embodiment" or "in an example" in various places throughout this specification are not necessarily all referring to the same embodiment or example, but may. Furthermore, the particular features, structures or characteristics may be combined in any suitable manner, as
20 would be apparent to one of ordinary skill in the art from this disclosure, in one or more embodiments.

Similarly it should be appreciated that in the above description of exemplary embodiments of the invention, various features of the invention are sometimes grouped together in a single embodiment, figure, or description thereof for the

purpose of streamlining the disclosure and aiding in the understanding of one or more of the various inventive aspects. This method of disclosure, however, is not to be interpreted as reflecting an intention that the claimed invention requires more features than are expressly recited in each claim. Rather, as the following claims
5 reflect, inventive aspects lie in less than all features of a single foregoing disclosed embodiment. Any claims following the Detailed Description are hereby expressly incorporated into this Detailed Description, with each claim standing on its own as a separate embodiment of this invention.

Furthermore, while some embodiments described herein include some but not other
10 features included in other embodiments, combinations of features of different embodiments are meant to be within the scope of the invention, and form different embodiments, as would be understood by those in the art. For example, in the following claims, any of the claimed embodiments can be used in any combination.

Thus, while there has been described what are believed to be the preferred
15 embodiments of the invention, those skilled in the art will recognize that other and further modifications may be made thereto without departing from the scope of the invention, and it is intended to claim all such changes and modifications as fall within the scope of the invention.

While the present invention has been disclosed with reference to particular details of
20 construction, these should be understood as having been provided by way of example and not as limitations to the scope of the invention.

CLAIMS:

1. A polymer wall bracket, the bracket being integrally formed, and including:

(a) an elongate upper surface for providing support to an object, the upper surface having a first end and a second end, and having side edges that each form an overhang lip;

(b) a mounting element located about the first end of the upper surface, the mounting element extending beneath, and substantially perpendicular to, the upper surface; and

(c) a pair of brace elements extending beneath the upper surface to a lower portion of the mounting element, wherein each brace element is a triangular side element which is spaced apart from, and substantially parallel to, the other brace element, wherein each triangular side element is perforated with a plurality of circular openings of different sizes, and the circular openings of both triangular side elements are coaxial, and wherein the sizes of the circular openings are such that they will support correspondingly different sizes of electrical lines or optical fibres when they are passed through any coaxial pair of circular openings in the spaced apart triangular side elements, and wherein a long edge of each triangular side element is reinforced with an integral stiffening rib, and the long edge also defines a bead for forming a channel between the bead and the stiffening rib.

2. The bracket according to claim 1, wherein the upper surface is perforated.

3. The bracket according to claim 1 or claim 2, wherein the upper surface defines an elongated rectangle having an array of through slots that are formed along the upper surface.

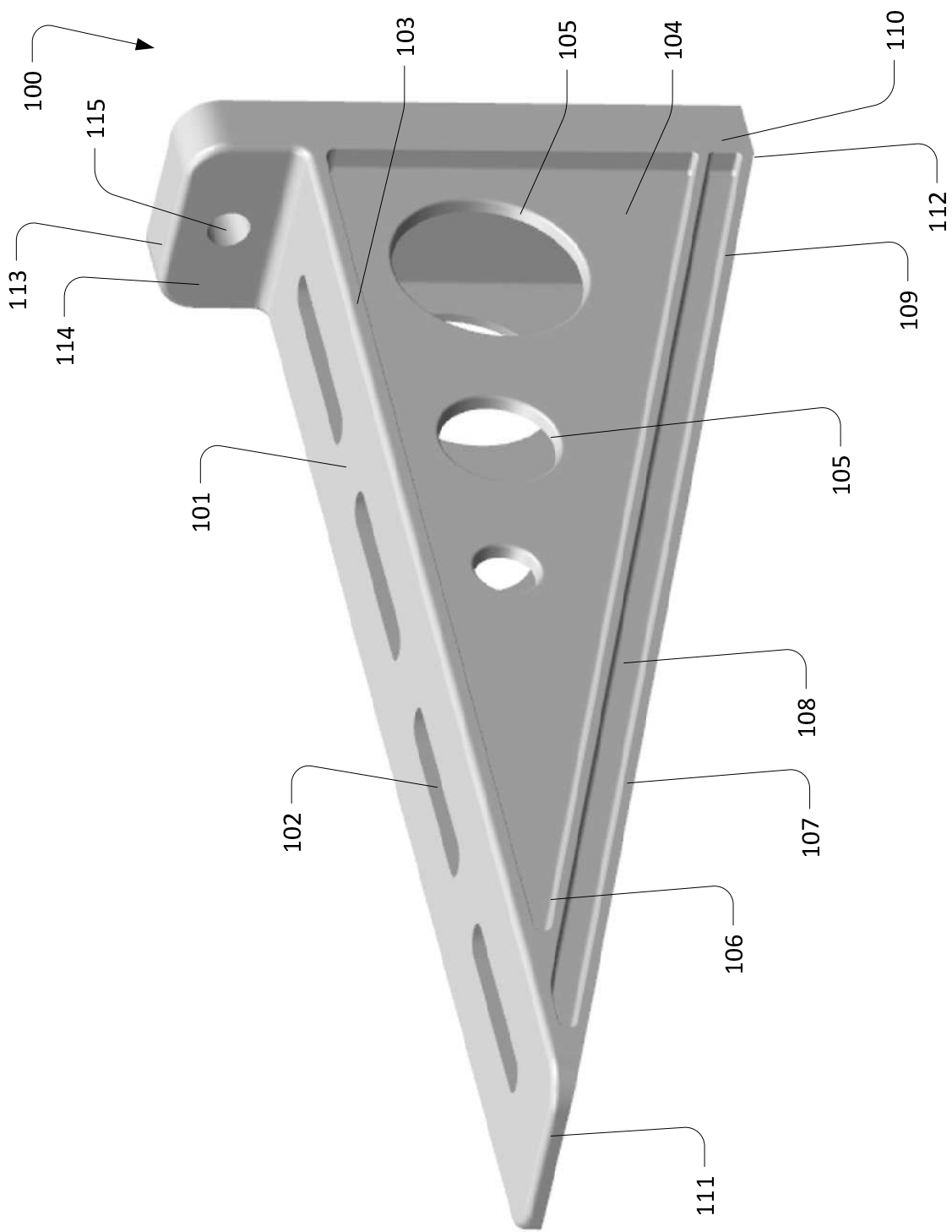

FIG. 1

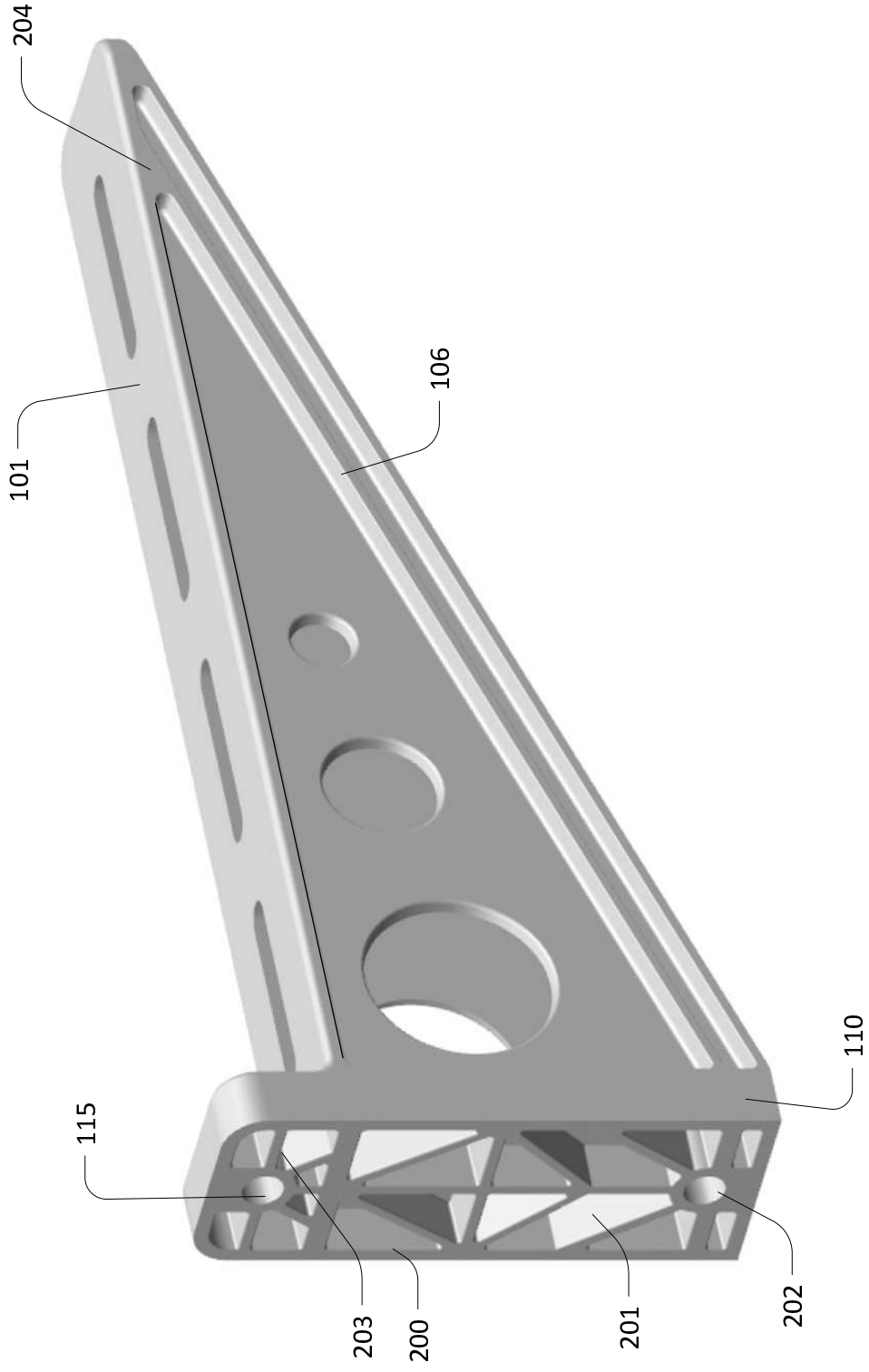

FIG. 2

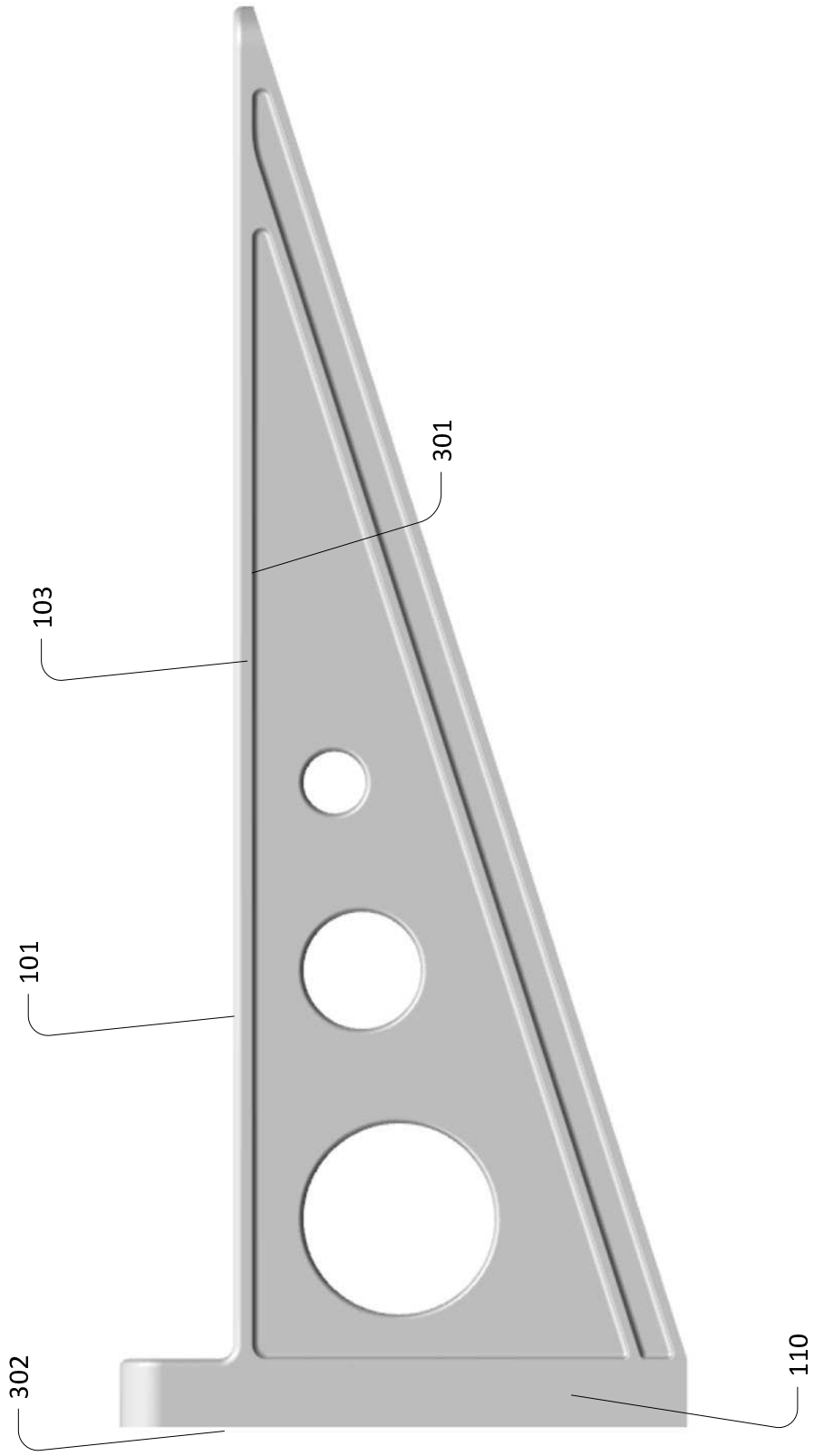

FIG. 3

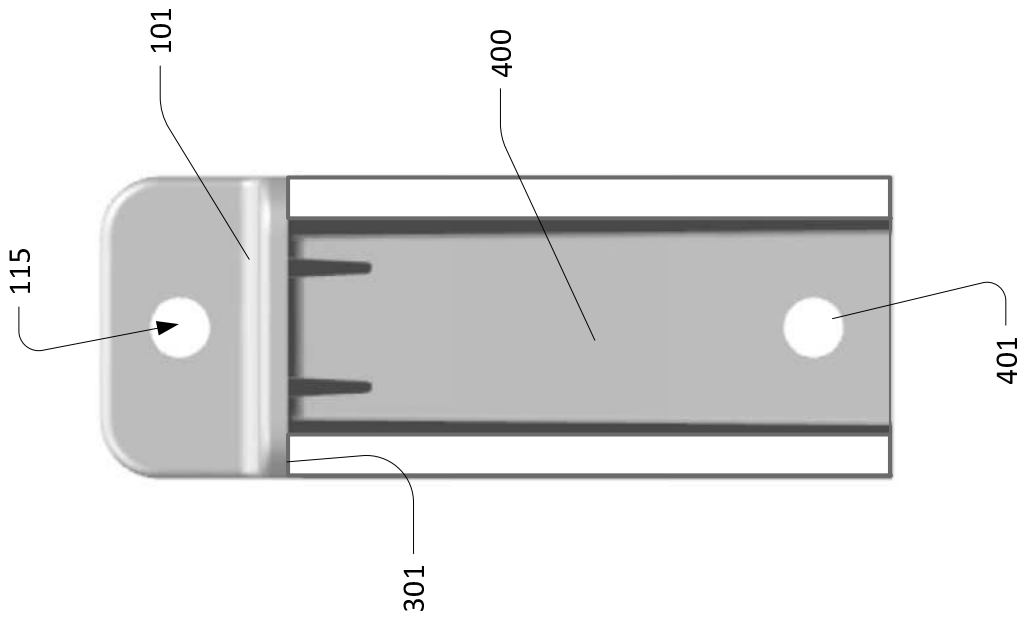

FIG. 4

5/5

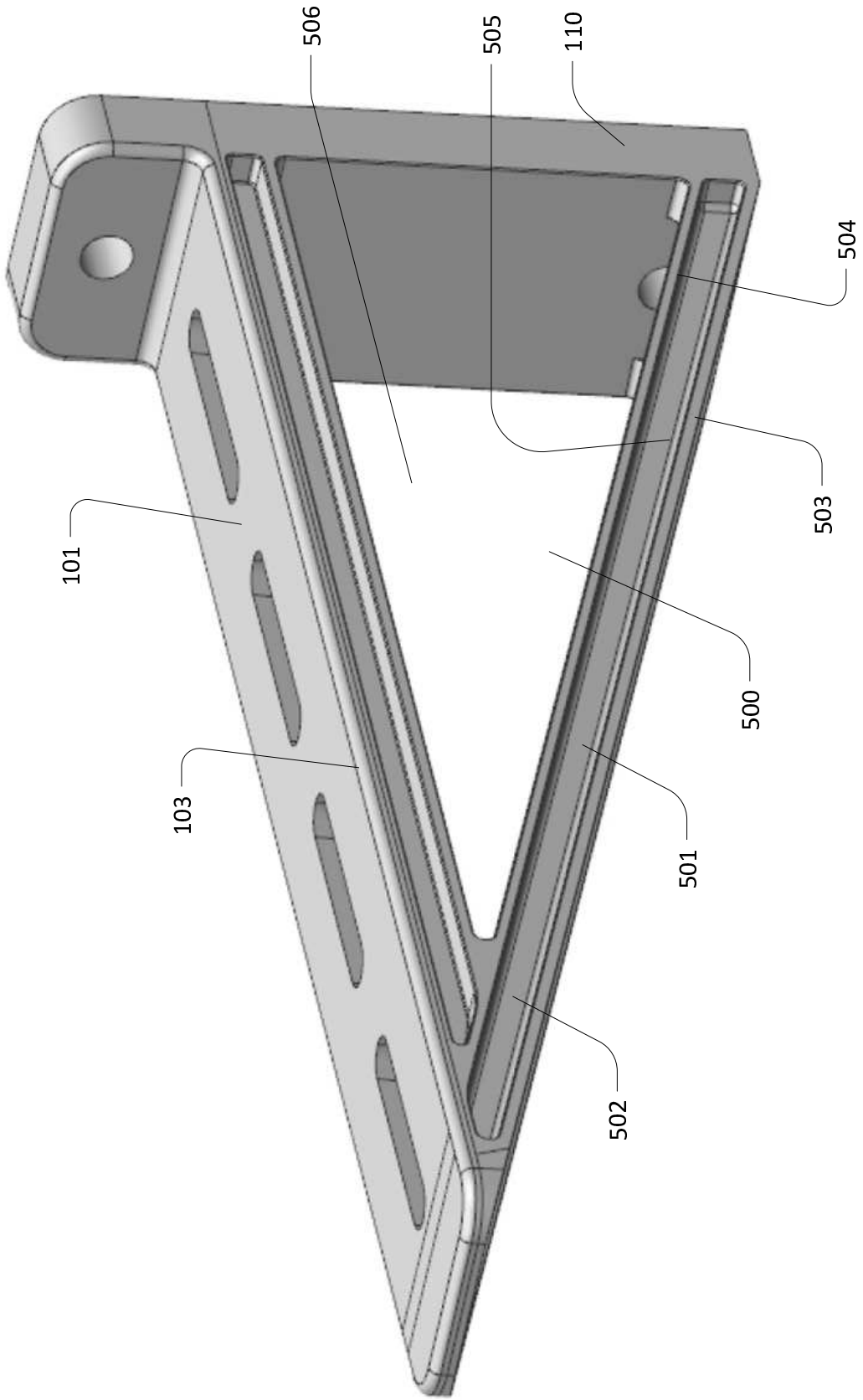

FIG.5