

(12) STANDARD PATENT APPLICATION (11) Application No. AU 2026201427 A1
(19) AUSTRALIAN PATENT OFFICE

(54) Title
SHIELDING DEVICE FOR ELECTRICAL WIRING, CABLING, PIPES AND THE LIKE

(51) International Patent Classification(s)
F16L 3/04 (2006.01) **F16L 57/06** (2006.01)

(21) Application No: **2026201427** (22) Date of Filing: **2026.02.25**

(43) Publication Date: **2026.03.19**

(43) Publication Journal Date: **2026.03.19**

(62) Divisional of:
2020256740

(71) Applicant(s)
Elecit Pty Ltd

(72) Inventor(s)
DI FABIO, Antonio;GUIDA, Massimo

(74) Agent / Attorney
**KINGS PATENT & TRADE MARKS ATTORNEYS PTY LTD, PO Box 128, Aspley, QLD,
4034, AU**

ABSTRACT

A shielding device for shielding electrical wiring, cabling, or pipes, is provided. The shielding device comprises: a shielding member, configured to shield from mechanical damage one or more electrical wires, cables or pipes that are traversing a joist or beam; and a retaining member, fixedly coupled to the shielding member, and configured to retain the shielding member in position adjacent to the joist or beam, to thereby shield the one or more electrical wires, cables or pipes.

SHIELDING DEVICE FOR ELECTRICAL WIRING, CABLING, PIPES AND THE LIKE

TECHNICAL FIELD

[0001] The present invention relates to shielding for the mechanical protection of electrical wiring, cabling, such as network or communications cabling, pipes, such as hot and cold water pipes and refrigerant pipes, and the like. In particular, although not exclusively, the present invention relates to shielding for mechanically protecting wiring, cabling and/or pipes in a ceiling from mechanical damage by persons in the ceiling or from objects falling from above.

BACKGROUND ART

[0002] It is common practice for wiring to be run in ceiling cavities of a building. Such wiring may be used to power lights in the ceiling, or be simply a means for providing wiring from one location to another for a wide variety of electrical applications. Traditionally, wiring has simply been run along joists of the ceiling from the one location to another.

[0003] Figure 1 illustrates a front view of such ceiling wiring arrangement 100, according to the prior art. The ceiling structure 100 includes a plasterboard ceiling panel 105 supported by parallel joists 110. Electrical wiring 115 extends across a ceiling space 120, and in particular runs across a top of the joists 110.

[0004] A problem with such wiring arrangement is that over time, access to the ceiling space 120 is needed, and in such case, persons in the ceiling space 120 may stand on the electrical wiring 115, which may immediately, or over time, damage the electrical wiring 115. In particular, to move around the ceiling space, persons must generally stand on the joists 110, and in such process may inadvertently stand on the wiring 115.

[0005] Figure 2 illustrates a side view of the ceiling wiring arrangement 100, illustrating an exemplary situation of a person 205 in the ceiling space 120 and standing on the electrical wiring 115. This may cause damage to the electrical wiring 115, which can in turn pose a safety risk to the person 205 and to others.

[0006] As such situation is clearly undesirable, more recent standards require the protection of electrical wiring from mechanical damage.

[0007] One such way of shielding electrical wiring is to use conduit (protective tubing) in the ceiling space, which shields an entirety of the wiring. A problem with using such conduit is that it is expensive and time consuming to use. A further problem with conduit is that it cannot be easily used in existing installations.

[0008] Another way to shield electrical wiring is to use off-cuts of timber, to shield the electrical wiring from one side. Figure 3 illustrates an exemplary ceiling wiring arrangement 300, according to the prior art.

[0009] The exemplary ceiling wiring arrangement 300 is similar to the wiring arrangement 100, but where a piece of timber 305 extends across adjacent joists 110 to thereby shield the electrical wiring 115 in that the electrical wiring 115 is positioned in a corner of the joists 110 and the timber 305.

[0010] As illustrated, even if the person 205 places his or her foot where the wiring 115 is located, the timber 305 shields the wiring 115 from damage.

[0011] One problem with such arrangement is that timber 305 is bulky, and as such is inconvenient and time consuming to install. Furthermore, if off-cuts are not available, such timber is costly.

[0012] A further problem with timber 305 is that it creates trip hazards in the ceiling space 120, and as a result, is more likely to cause injury to the person 205.

[0013] Yet further again, such arrangement is not particularly suitable when multiple wires need protection.

[0014] Similar problems exist for cabling, such as network and communication cabling, pipes, such as hot and cold water pipes, refrigerant pipes (e.g. for air conditioning or cool rooms), and the like.

[0015] As such, there is clearly a need for improved mechanical protection for electrical wiring, cabling, pipes and the like.

[0016] It will be clearly understood that, if a prior art publication is referred to herein, this reference does not constitute an admission that the publication forms part of the common general knowledge in the art in Australia or in any other country.

SUMMARY OF INVENTION

[0017] The present invention is directed to shields for providing mechanical protection to electrical wiring, cabling, pipes and the like, which may at least partially overcome at least one of the abovementioned disadvantages or provide the consumer with a useful or commercial choice.

[0018] With the foregoing in view, the present invention in one form, resides broadly in a

shielding device for shielding electrical wiring, cabling, or pipes, the shielding device comprising:

a shielding member, configured to shield from mechanical damage one or more electrical wires, cables or pipes that are traversing a joist or beam; and

a retaining member, fixedly coupled to the shielding member, and configured to retain the shielding member in position adjacent to the joist or beam, to thereby shield the one or more electrical wires, cables or pipes.

[0019] Advantageously, the shielding device enables the wires, cables, or pipes, e.g. in a ceiling space, to be mechanically protected, to thereby prevent the damage to the wires, cables or pipes, e.g. when a person is later in the ceiling space.

[0020] The shielding device may be adapted to be installed to shield the wires, cables or pipes after the wires, cables or pipes have been installed. The shielding device may be adapted to be installed above pre-existing wires, cables or pipes, without having to move or disconnect the wires, cables or pipes.

[0021] Preferably, the shielding device includes first and second retaining members.

[0022] The first and second retaining members may be positioned on opposing sides of the shielding member. The shielding member may be configured to shield the wires, cables or pipes from above, and be open from below. Such configuration enables the device to be installed directly above the wires, cables or pipes without interrupting the wires, cables or pipes in any way.

[0023] The retaining member may include an opening, which is rectangular in cross section.

[0024] The retaining member may include an opening which is adapted to receive at least an upper edge of the joist or beam. The retaining member may be adapted to fit snugly around an upper end of the joist or beam.

[0025] The retaining members may include an opening that is substantially rectangular in cross section.

[0026] The retaining members may include a substantially planar upper wall, with substantially planar side walls extending downwardly therefrom. The substantially planar side walls may extend downwardly from opposing sides thereof. The substantially planar side walls may extend downwardly from the substantially planar upper wall at an angle of about 90 degrees.

[0027] The retaining members may include apertures for fastening the retainer to the joist or beam. The retaining members may include apertures on an upper surface. The retaining members may include apertures on a side surface. The retaining members may include apertures on an upper and a side surface. Such configuration may simplify installation from above (where it is desirable to install fasteners from above), and installation from below (where it is desirable to install fasteners from the side). The fasteners may comprise screws or nails.

[0028] The shielding member may be shaped to reduce the likelihood of tripping on the shielding member. The shielding member may extend upwardly from the retaining members at an angle of between about 40-50 degrees.

[0029] The shielding member may comprise first and second substantially planar portions to form a chevron (inverted "v") shape.

[0030] The shielding member may be curved.

[0031] The shielding member may extend laterally further than edges of the retaining members, to thereby provide an overhang. The shielding member may be at least twice as wide as the retaining members.

[0032] The shielding member may be configured to shield the wires, cables or pipes that extends across a joist, wherein the retaining members are coupled to the joist.

[0033] The shielding device may be unitarily formed. The shielding device may be formed of plastic. The shielding device may be injection moulded.

[0034] The shielding device may be brightly coloured, to thereby simplify identification of the shielding device in a ceiling.

[0035] In another form, the present invention resides broadly in an electrical wiring shielding device comprising:

a shielding member, configured to shield one or more electrical wires that are traversing a joist or beam in a ceiling space from mechanical damage by a person in the ceiling space; and

a retaining member, fixedly coupled to the shielding member, and configured to retain the shielding member to the joist or beam to shield the one or more electrical wires.

[0036] Any of the features described herein can be combined in any combination with any one or more of the other features described herein within the scope of the invention.

[0037] The reference to any prior art in this specification is not, and should not be taken as an acknowledgement or any form of suggestion that the prior art forms part of the common general knowledge.

BRIEF DESCRIPTION OF DRAWINGS

[0038] Various embodiments of the invention will be described with reference to the following drawings, in which:

[0039] Figure 1 illustrates a front view of a ceiling wiring arrangement, according to the prior art.

[0040] Figure 2 illustrates a side view of the ceiling wiring arrangement of Figure 1, illustrating an exemplary situation of a person in a ceiling space and standing on electrical wiring.

[0041] Figure 3 illustrates another exemplary ceiling wiring arrangement, according to the prior art.

[0042] Figure 4 illustrates a side view of an electrical wire shielding device, according to an embodiment of the present invention.

[0043] Figure 5 illustrates a top view of the shielding device of Figure 4.

[0044] Figure 6 illustrates a front view of the shielding device of Figure 4.

[0045] Figure 7 illustrates a side view of the electrical wire shielding device of Figure 4 installed in a ceiling cavity of a new residential building.

[0046] Figure 8 illustrates a side view of a pipe shielding device installed in a ceiling cavity of a building, according to an embodiment of the present invention.

[0047] Preferred features, embodiments and variations of the invention may be discerned from the following Detailed Description which provides sufficient information for those skilled in the art to perform the invention. The Detailed Description is not to be regarded as limiting the scope of the preceding Summary of the Invention in any way.

DESCRIPTION OF EMBODIMENTS

[0048] Embodiments of the present invention are disclosed which provide an easy, inexpensive and lightweight way of shielding wiring, cables and pipes in the ceiling space of a building, such as a residential building.

[0049] Figure 4 illustrates a side view of an electrical wire shielding device 400, according to an embodiment of the present invention. Figure 5 illustrates a top view of the shielding device 400, and Figure 6 illustrates a front view of the shielding device 400. The shielding device 400 is particularly suited for shielding wiring in a ceiling space of a residential dwelling, but may also be used to shield pipes (e.g. water or refrigerant) and cables (e.g. communications), and may also be used in commercial buildings and other non-residential buildings.

[0050] The shielding device 400 includes a shielding member 405, and retaining members 410, the shielding member 405 configured to shield electrical wiring from above, and the retaining member 410 configured to retain the shielding device 400 to a joist, beam or the like.

[0051] The shielding member 405 extends upwardly and outwardly from a first of the retaining members 410, and then extends back down do a second of the retaining members 410. The first and second retaining members 410 are spaced apart by the shielding member 405 such that the shielding member 405 is open from below. This enables the shielding device to be placed over pre-installed wiring.

[0052] The shielding member 405 comprises first and second substantially planar walls 405a, that extend upwardly and outwardly from each of the retaining members 410 at an angle of about 40-50 degrees, to thereby provide a chevron-shaped shield to the wiring. Such shape is less likely to be a tripping hazard than a rectangular shape, as it has does not have any vertically extending walls in profile.

[0053] As best illustrated in Figure 6, the retaining members 410 each include an opening 415 which is rectangular in cross section, and which is configured to receive a rectangular member, such as a joist. In particular, the retaining members 410 each comprise a substantially planar upper wall 410a, from which substantially planar sidewalls 410b downwardly extend. The sidewalls 410b extend downwardly from opposing edges of the upper wall 410a at an angle of about 90 degrees.

[0054] As best illustrated in Figures 5 and 6, the shielding member 405 not only shields the space between the retaining members 410, but also extends laterally from edges of the retaining members 410 to thereby provide a shield that not only shields directly above the joist, or other timber member, but also immediately adjacent thereto.

[0055] Preferably, the opening is about 45mm wide, such that it is configured to receive a joist that is about 45mm wide. However, the skilled addressee will readily appreciate that the opening may be selected to suit any suitable size of timber.

[0056] As illustrated in Figures 4 and 5, each of the retaining members 410 includes an upper retaining aperture 420a, and side retaining apertures 420b. These apertures enable the shielding device 400 to be permanently attached to a joist, beam (or other timber member) using screws or nails.

[0057] By providing retaining apertures 420a, 420b on both the top and side of the retaining members 410, the shielding device 400 may be easily installed from above (e.g. from inside the ceiling space), or from below (e.g. from under the ceiling space prior to installation of the plasterboard ceiling).

[0058] The shielding device 400 is suitable both for new wiring installations, and existing wiring installations. In particular, the shielding device 400 may be positioned over wiring that already exists in a ceiling space, for example, which may be required when making changes to the wiring to conform to relevant standards.

[0059] Figure 7 illustrates a side view of the electrical wire shielding device 400 installed in a ceiling cavity of a new residential building. As will be readily appreciated by the skilled addressee, a similar installation is performed on other types of buildings.

[0060] In this exemplary installation, electrical wiring 115 is initially run across joists 110 of the building, and prior to a ceiling being installed. This may be performed from below, as will be readily appreciated by the skilled addressee.

[0061] When the wiring 115 has been installed, it may be determined which parts of the wiring 115 need to be shielded. For each of the areas of wiring that do need to be shielded, an electrical wire shielding device 400 may be placed above the wire 115 at that point. In particular, the shielding member 405 may be positioned such that it extends over the wiring 115 while the from the retaining members 410 align with the joist 110. The electrical wire shielding device 400 may then be lowered such that it is supported by the joist 110, while the shielding member 405 is still shielding the wire 115.

[0062] At this point, the electrical wire shielding device 400 may then be attached to the joist 110 using screws 705, which extend through the apertures 420b. This may be achieved from below, prior to installation of the ceiling, thereby alleviating the need to enter the ceiling space.

[0063] The electrical wire shielding device 400 is unitarily formed of plastic, and may be formed by injection moulding.

[0064] In one embodiment, the electrical wire shielding device 400 is formed of a brightly

coloured material (e.g. bright pink). This enables a person later in the ceiling space to easily identify the electrical wire shielding device 400 and thereby avoid standing on same.

[0065] While the above device illustrates a chevron (inverted “v”) shaped shielding member 405, the skilled address will readily appreciate that many other suitable shapes may be used. As an illustrative example, a curved shielding member may be used. As another example, a shielding member that is substantially rectangular or square in cross section (with an open base) may be used.

[0066] The shielding member 405 is sized to receive a plurality of wires, and is therefore able to shield multiple wires. This may further enable subsequent wiring that is provided in a ceiling space to utilise existing electrical wire shielding devices 400.

[0067] While the shielding member 405 has been described with reference to shielding electrical wiring, the skilled addressee will readily appreciate that it may be used in a similar manner to shield cabling (e.g. telecommunications cabling, fibre optic cabling or signal cabling), piping (e.g. water or refrigerant pipes), or the like. In some cases, the shielding member 405 may be enlarged to accommodate larger pipes.

[0068] Figure 8 illustrates a side view of a pipe shielding device 800 installed in a ceiling cavity of a building, according to an embodiment of the present invention. The pipe shielding device 800 is similar to the pipe shielding device 100 but is sized to accommodate larger piping.

[0069] The shielding device 800 includes a shielding member 805, similar to the shielding member 405, but larger, to accommodate larger piping, such as refrigerant (air conditioning) piping, and retaining members 410.

[0070] The shielding member 805 includes first and second substantially planar walls 805a, each of which is about 80mm from base to tip. Compared to the shielding member 405, the shielding member 805 is of a similar shape, and provides a chevron-shaped shield to piping 815.

[0071] The piping 815 is refrigerant piping, and comprises a copper pipe 815a at its core, with an insulating sheath 815 around the copper pipe 815a. As such, the piping 815 is relatively bulky.

[0072] The shielding member 805 is configured to shield the piping 815 from above, and the retaining member 410 is configured to retain the shielding device 800 to a joist or the like.

[0073] The piping 815 may comprise air conditioning pipework (e.g. pipework between the evaporator and condenser), refrigeration pipework (e.g. pipework between a cold room and an

outdoor unit), hot or cold water pipes, venting pipes, or any other suitable pipework.

[0074] Advantageously, the shielding devices described above provide an easy, inexpensive and lightweight way of shielding wiring, e.g. to conform to an appropriate wiring standard. An example of one such standard is AS/NZS 3000:2018, which requires that wiring systems which are likely to be disturbed (e.g. in ceiling space where access is greater than 0.6m in height) are protected from mechanical damage. Similarly, the shielding devices may be used to shield other wiring, cabling, pipes and the like.

[0075] The devices may be installed from above or below, thereby providing flexibility and convenience in installations, and enable the devices to be used in an efficient manner in both new installations and retrofits.

[0076] The devices are easy to identify, and in any event are adapted to reduce a tripping hazard in the ceiling space.

[0077] In the present specification and claims (if any), the word 'comprising' and its derivatives including 'comprises' and 'comprise' include each of the stated integers but does not exclude the inclusion of one or more further integers.

[0078] Reference throughout this specification to 'one embodiment' or 'an embodiment' means that a particular feature, structure, or characteristic described in connection with the embodiment is included in at least one embodiment of the present invention. Thus, the appearance of the phrases 'in one embodiment' or 'in an embodiment' in various places throughout this specification are not necessarily all referring to the same embodiment. Furthermore, the particular features, structures, or characteristics may be combined in any suitable manner in one or more combinations.

[0079] In compliance with the statute, the invention has been described in language more or less specific to structural or methodical features. It is to be understood that the invention is not limited to specific features shown or described since the means herein described comprises preferred forms of putting the invention into effect. The invention is, therefore, claimed in any of its forms or modifications within the proper scope of the appended claims (if any) appropriately interpreted by those skilled in the art.

CLAIMS

1. A shielding device for shielding electrical wiring, cabling, or pipes, the shielding device comprising:
 - a shielding member, configured to shield from mechanical damage one or more electrical wires, cables or pipes that are traversing a joist or beam; and
 - a retaining member, fixedly coupled to the shielding member, and configured to retain the shielding member in position adjacent to the joist or beam, to thereby shield the one or more electrical wires, cables or pipes.
2. The shielding device of claim 1, adapted to be installed above pre-existing wires, cables or pipes, without having to move or disconnect the wires, cables or pipes.
3. The shielding device of claim 1, including first and second retaining members.
4. The shielding device of claim 3, wherein the first and second retaining members are positioned on opposing sides of the shielding member.
5. The shielding device of claim 1, configured to shield the wires, cables or pipes from above, and be open from below.
6. The shielding device of claim 1, wherein the retaining member includes an opening, which is rectangular in cross section.
7. The shielding device of claim 1, wherein the retaining member includes an opening which is adapted to receive at least an upper edge of the joist or beam.
8. The shielding device of claim 7, wherein the retaining member is adapted to fit snugly around an upper end of the joist or beam.
9. The shielding device of claim 1, wherein the retaining member includes a substantially planar upper wall, with substantially planar side walls extending downwardly therefrom.
10. The shielding device of claim 9, wherein the substantially planar side walls extend downwardly from opposing sides of the planar upper wall.
11. The shielding device of claim 10, wherein the substantially planar side walls extend downwardly from the substantially planar upper wall at an angle of about 90 degrees.
12. The shielding device of claim 1, wherein the retaining members include apertures for

fastening the retainer to the joist or beam.

13. The shielding device of claim 12, wherein the retaining members include apertures on both upper and side surfaces thereof.

14. The shielding device of claim 1, wherein the shielding member is shaped to reduce a likelihood of tripping on the shielding member.

15. The shielding device of claim 1, wherein the shielding member extends upwardly from the retaining member at an angle of between about 40-50 degrees.

16. The shielding device of claim 1, wherein the shielding member comprises first and second substantially planar portions to form a chevron shape.

17. The shielding device of claim 1, wherein the shielding member extends laterally further than edges of the retaining members, to thereby provide an overhang.

18. The shielding device of claim 17, wherein the shielding member is at least twice as wide as the retaining members.

19. The shielding device of claim 1, wherein the shielding device is unitarily formed.

20. The shielding device of claim 1, wherein the shielding device is brightly coloured, to thereby simplify identification of the shielding device.

21. An electrical wiring shielding device comprising:

a shielding member, configured to shield one or more electrical wires that are traversing a joist or beam in a ceiling space from mechanical damage by a person in the ceiling space; and

a retaining member, fixedly coupled to the shielding member, and configured to retain the shielding member to the joist or beam to shield the one or more electrical wires.

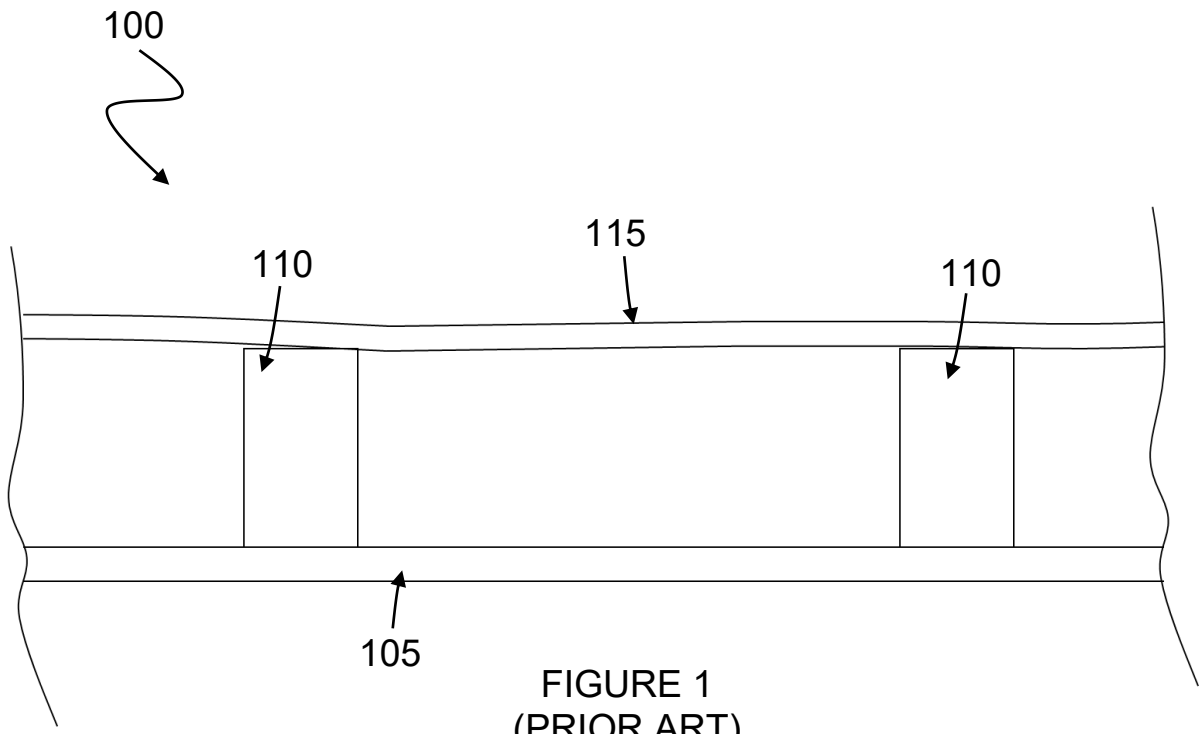

FIGURE 1
(PRIOR ART)

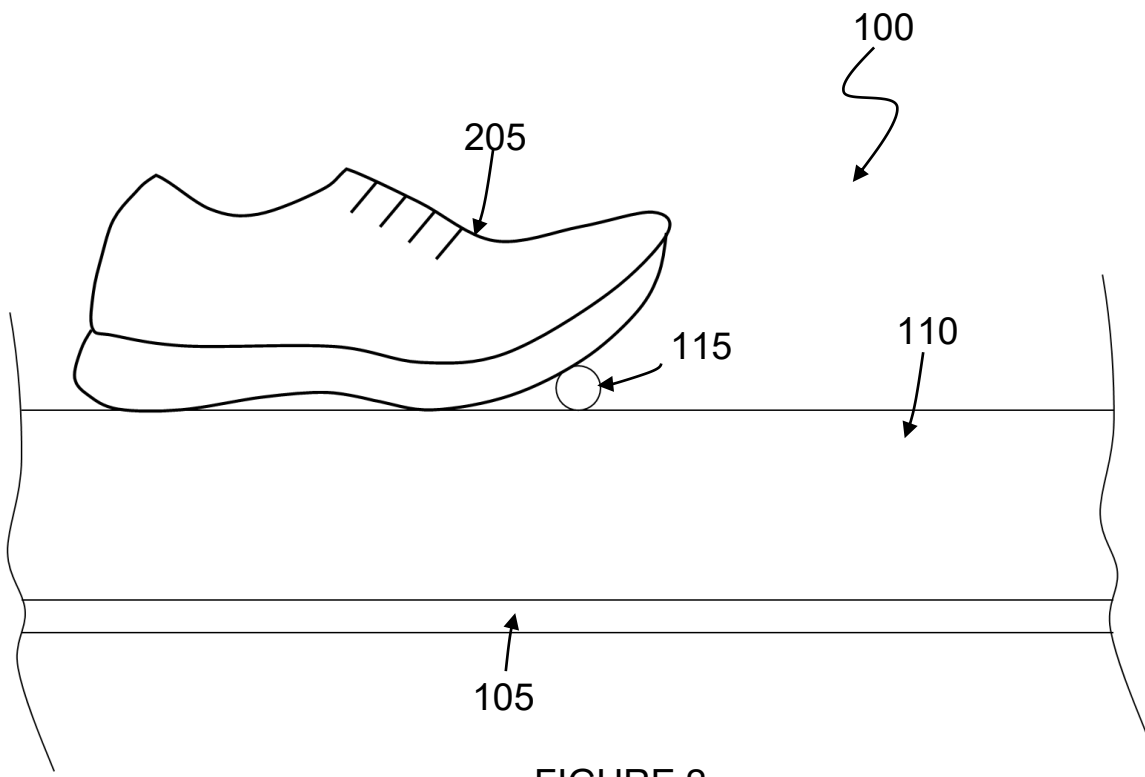

FIGURE 2
(PRIOR ART)

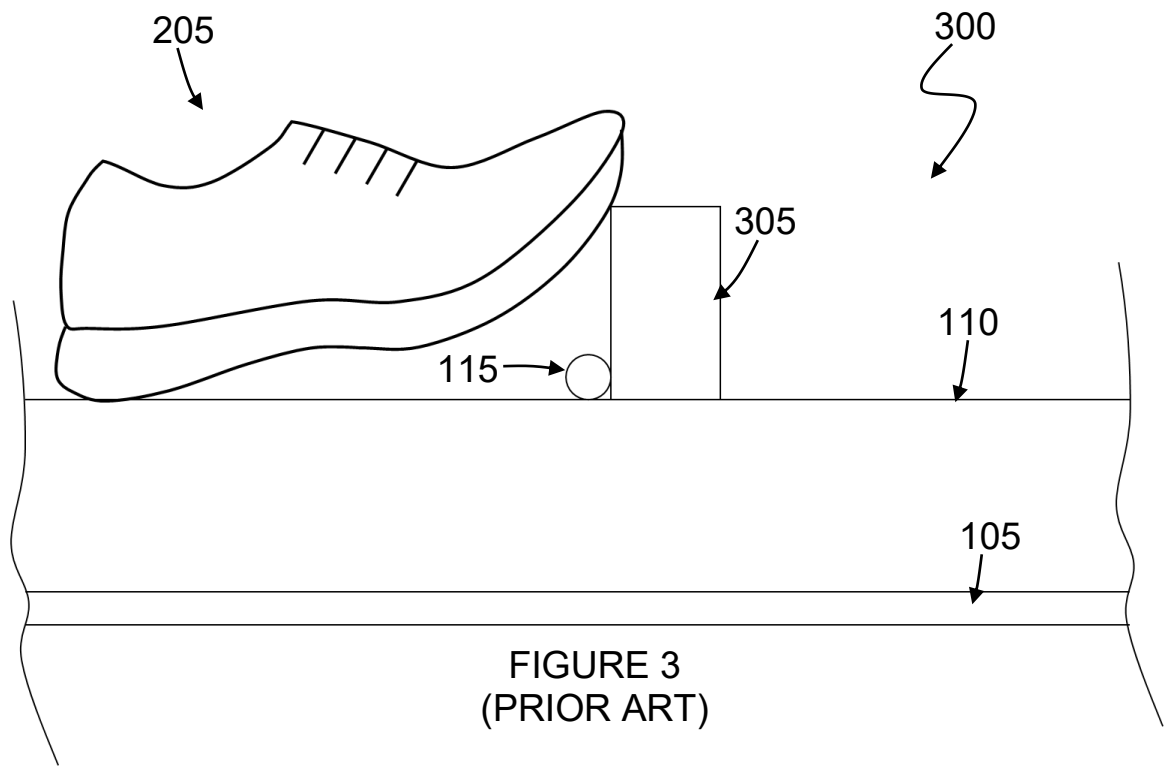

FIGURE 3
(PRIOR ART)

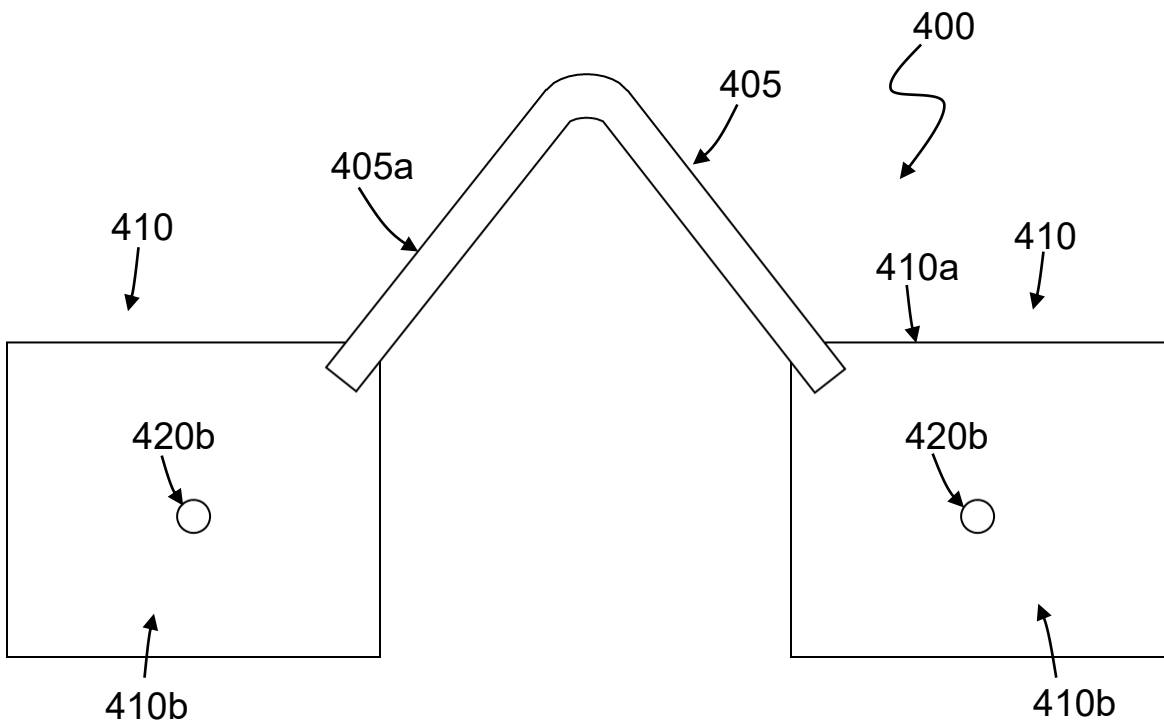

FIGURE 4

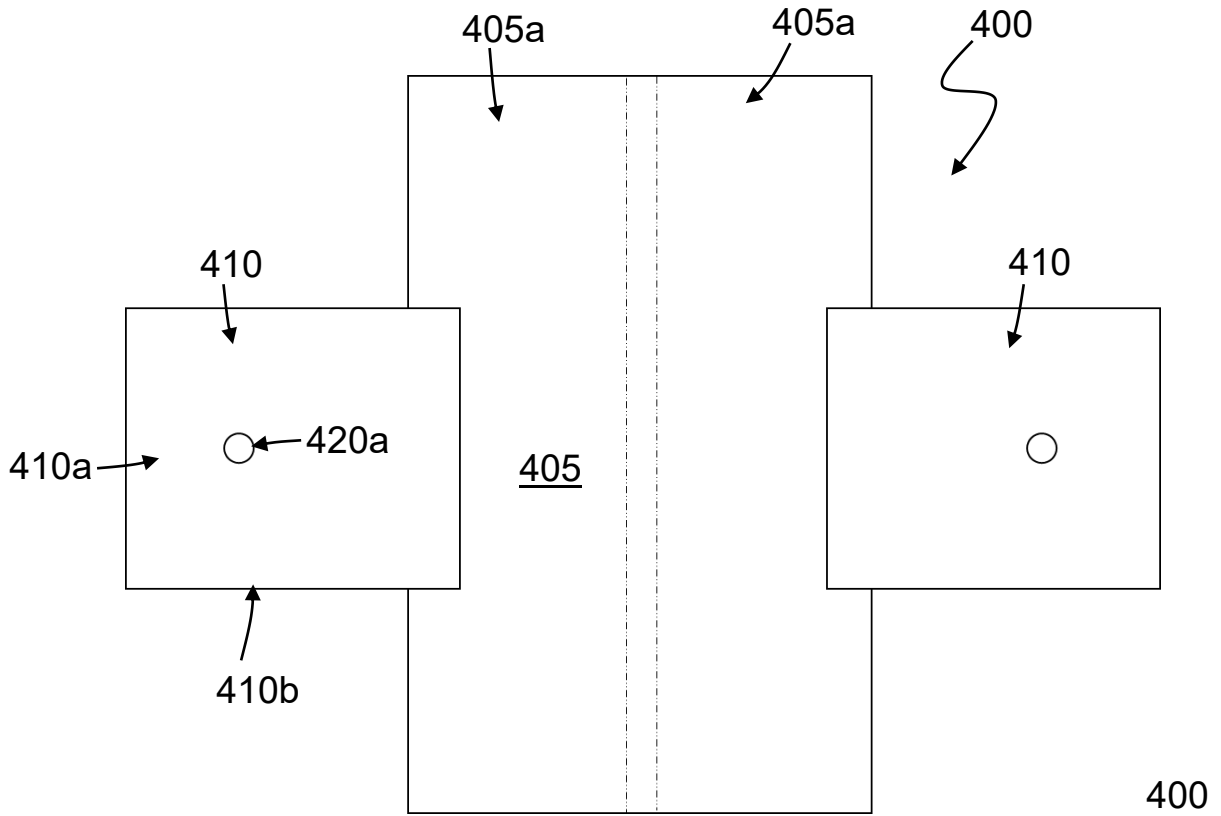

FIGURE 5

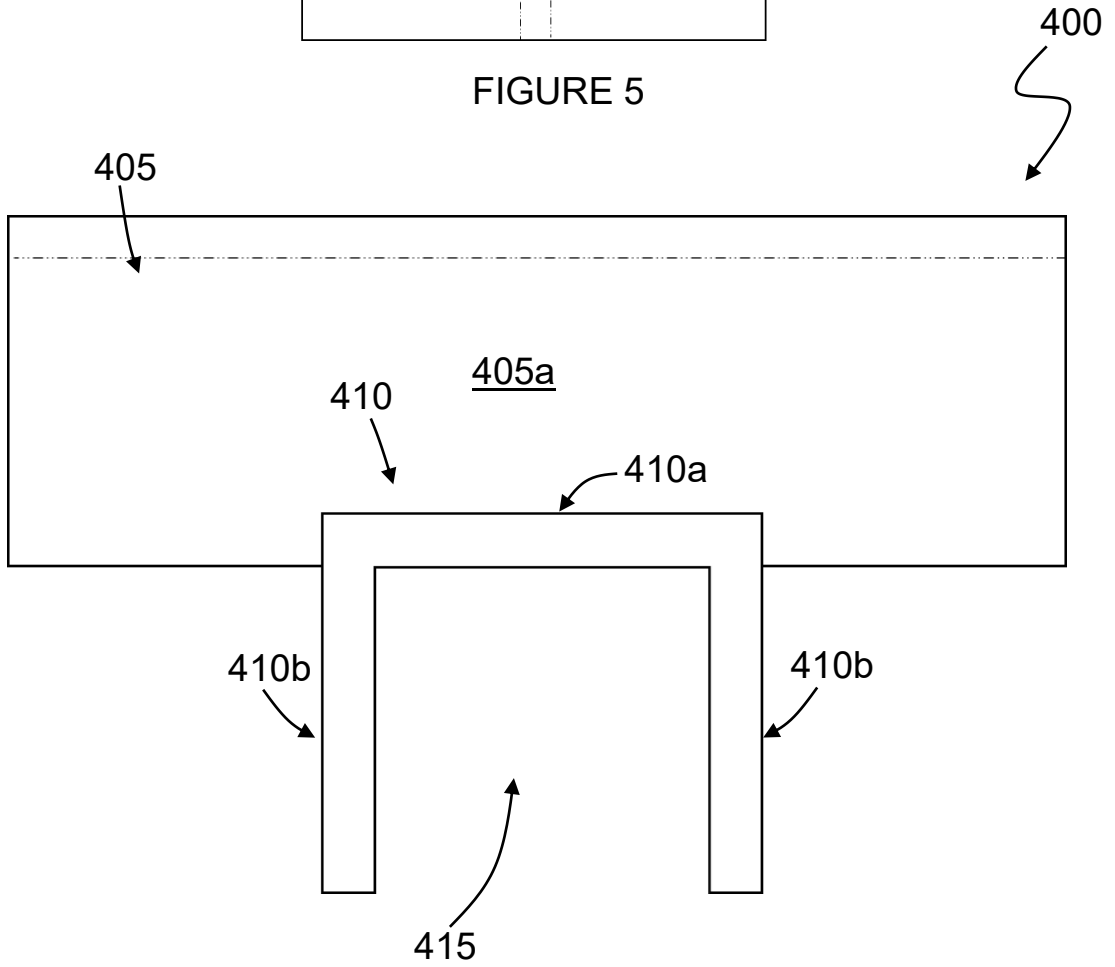

FIGURE 6

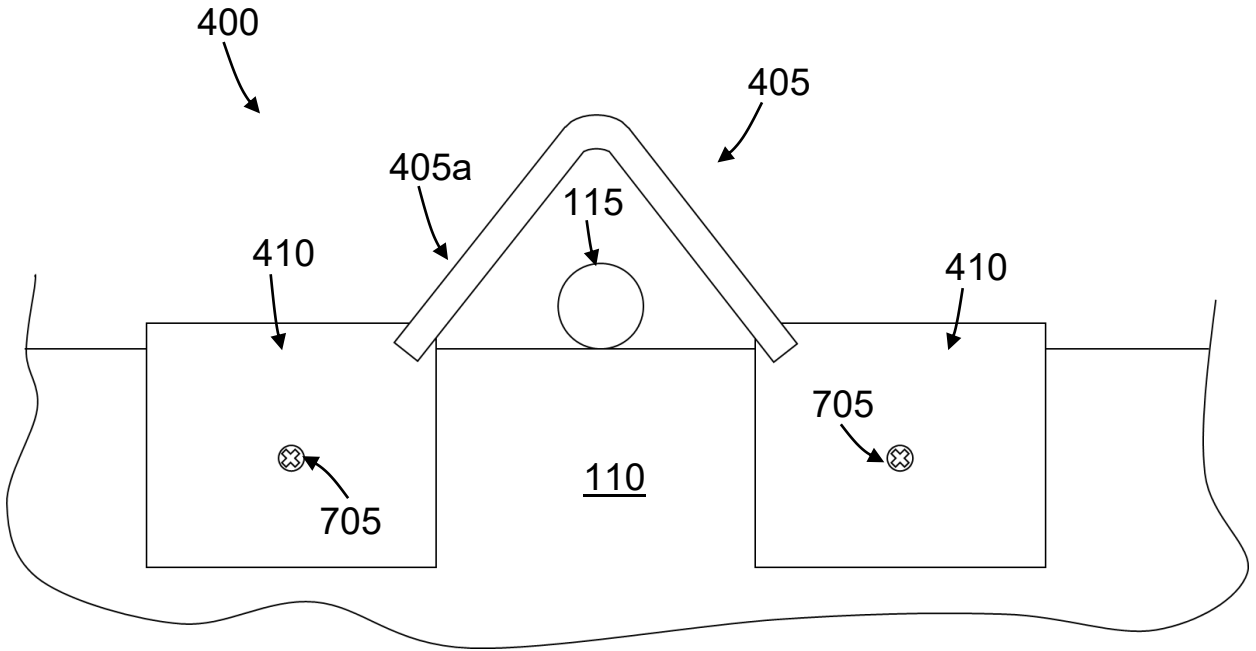

FIGURE 7

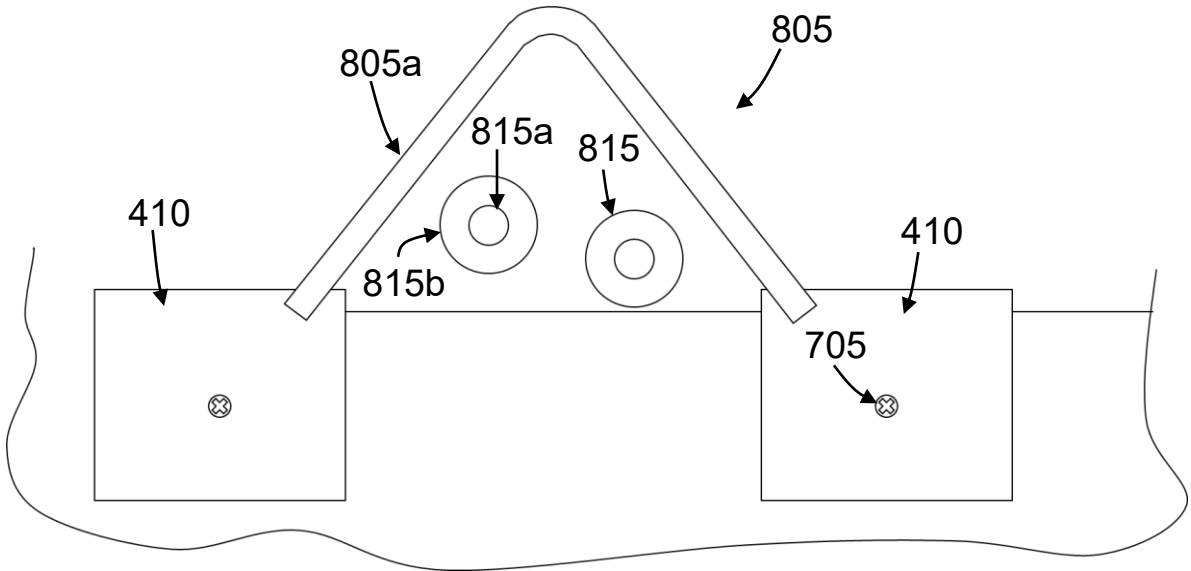

FIGURE 8