

**(12) STANDARD PATENT APPLICATION** (11) Application No. **AU 2026201485 A1**  
**(19) AUSTRALIAN PATENT OFFICE**

- (54) Title  
**A METHOD OF OPERATING A GAMING MACHINE AND A GAMING MACHINE**
- (51) International Patent Classification(s)  
**G07F 17/32** (2006.01) **G07F 17/34** (2006.01)
- (21) Application No: **2026201485** (22) Date of Filing: **2026.02.26**
- (43) Publication Date: **2026.03.19**  
(43) Publication Journal Date: **2026.03.19**
- (62) Divisional of:  
**2024200346**
- (71) Applicant(s)  
**Aristocrat Technologies Australia Pty Limited**
- (72) Inventor(s)  
**KIM, Hyong Joo**
- (74) Agent / Attorney  
**Griffith Hack, Level 15, 376-390 Collins Street, Melbourne, VIC, 3000, AU**

ABSTRACT:

5 A gaming machine comprises a plurality of reel strips including a plurality of first reel strips, at least one of the first reel strips having a hidden symbol and at least one, second overlay reel strip comprising an overlay, a player interface comprising a display for displaying game outcomes, a random number generator, and a game controller, The game controller is arranged to randomly select a  
10 plurality of symbols from the first reel strips by using the random number generator to select stopping positions for each of the plurality of first reel strips, display the selected symbols of the first reel strips with the display, and randomly select, using the random number generator, a  
15 stopping position for each at least one second overlay reel strip comprising an overlay. Responsive to the overlay being located on a selected hidden symbol, the hidden symbol is made visible on the display but otherwise the hidden symbol remains hidden, and the game controller makes an award that  
20 is modified in accordance with the hidden symbol upon the hidden symbol being made visible.

**A METHOD OF OPERATING A GAMING MACHINE AND A GAMING MACHINE**

**Related Application**

5 This application is a divisional application of Australian  
application no. 2024200346, which, in turn, is a divisional  
application of Australian application no. 2021277711, which,  
in turn, is a divisional application of Australian application  
no. 2019240706, which, in turn, is a divisional application of  
10 Australian application no. 2017213538, which, in turn, is a  
divisional application of Australian application no.  
2015202873 which, in turn, is a divisional application of  
Australian application no. 2012201131 which, in turn, is a  
divisional application of Australian application no.  
15 2008249156 which, in turn, is a divisional application of  
Australian application no.2019240706. The disclosures of each  
of these applications are incorporated herein by reference.

**Field of the Invention**

20 This invention relates to a method of operating a gaming  
machine and a gaming machine.

**Background of the Invention**

25 Many different gaming systems are known in which symbols are  
displayed in order to provide a game on which a wager can be  
made. Typically such games are played on so-called "poker  
machines". Usually the symbols are displayed on a mechanical  
30 reel, or in more recent times on a video display. A winning  
game is determined based on the displayed symbols.

A need exists for an alternative gaming system.

35 **Summary of the Invention**

The present invention may be said to reside in a gaming  
machine comprising:

40 a plurality of reel strips including a plurality of  
first reel strips, at least one of the first reel strips

2026201485 26 Feb 2026

having a hidden symbol and at least one, second overlay reel strip comprising an overlay;

a player interface comprising a display for displaying game outcomes;

5 a random number generator; and

a game controller arranged to:

randomly select a plurality of symbols from the first reel strips by using the random number generator to select stopping positions for each of the plurality of first reel strips;

10 display the selected symbols of the first reel strips with the display; and

randomly select, using the random number generator, a stopping position for each at least one second overlay reel strip comprising an overlay,

15 wherein responsive to the overlay being located on a selected hidden symbol, the hidden symbol is made visible on the display but otherwise the hidden symbol remains hidden, and

20 the game controller makes an award that is modified in accordance with the hidden symbol upon the hidden symbol being made visible.

In an embodiment, the overlay comprises a transparent window of a predetermined colour and the hidden symbol is a different colour to the predetermined colour, the visible symbol being the same colour as the predetermined colour.

In an embodiment, there are a plurality of second, overlay reel strips.

In an embodiment, the display includes the visible part of a mechanical device and the first reel strips and each second, overlay reel strip are components of a mechanical reel system.

35

### **Brief Description of the Drawings**

An embodiment of the invention will be described, by way of example, with reference to the accompanying drawings in which:

40

2026201485 26 Feb 2026

Figure 1 is a block diagram of the core components of a gaming system;

5 Figure 2 is a perspective view of a stand alone gaming machine;

Figure 3 is a block diagram of the functional components of a gaming machine;

10 Figure 4 is a schematic diagram of the functional components of a memory;

Figure 5 is a schematic diagram of a network gaming system;

15 Figure 6 is a view of a symbol according to one embodiment of the invention;

Figure 7 is a view of the symbol of Figure 6 as is actually observed by a player;

20

Figure 8 is a view of the symbol of Figure 6 having a transparent window overlaid on the symbol;

25 Figure 9 is a view of a display according to an embodiment of the invention;

Figure 10 is a view of the display of Figure 9 illustrating an embodiment of the invention;

30 Figure 11 is a flowchart relating to the embodiment of the invention; and

Figure 12 is a functional block module diagram relating to the embodiment of the invention.

35

**Detailed Description of an Embodiment of the Invention**

Referring to the drawings, there is shown a gaming system arranged to implement a game where a transparent overlay can reveal a hidden symbol. The gaming system can take a number

40

2026201485 26 Feb 2026

of different forms.

In a first form, a stand alone gaming machine is provided wherein all or most components required for implementing the game are present in a player operable gaming machine.

In a second form, a distributed architecture is provided wherein some of the components required for implementing the game are present in a player operable gaming machine and some of the components required for implementing the game are located remotely relative to the gaming machine. For example, a "thick client" architecture may be used wherein part of the game is executed on a player operable gaming machine and part of the game is executed remotely, such as by a gaming server; or a "thin client" architecture may be used wherein most of the game is executed remotely such as by a gaming server and a player operable gaming machine is used only to display audible and/or visible gaming information to the player and receive gaming inputs from the player.

However, it will be understood that other arrangements are envisaged. For example, an architecture may be provided wherein a gaming machine is networked to a gaming server and the respective functions of the gaming machine and the gaming server are selectively modifiable. For example, the gaming system may operate in stand alone gaming machine mode, "thick client" mode or "thin client" mode depending on the game being played, operating conditions, and so on. Other variations will be apparent to persons skilled in the art.

Irrespective of the form, the gaming system comprises several core components. At the broadest level, the core components are a player interface 50 and a game controller 60 as illustrated in Figure 1. The player interface is arranged to enable manual interaction between a player and the gaming system and for this purpose includes the input/output components required for the player to enter instructions and play the game.

Components of the player interface may vary from embodiment to

2026201485 26 Feb 2026

embodiment but will typically include a credit mechanism 52 to enable a player to input credits and receive payouts, one or more displays 54, a game play mechanism 56 that enables a player to input game play instructions (e.g. to place bets), and one or more speakers 58.

The game controller 60 is in data communication with the player interface and typically includes a processor 62 that processes the game play instructions in accordance with game play rules and outputs game play outcomes to the display. Typically, the game play instructions are stored as program code in a memory 64 but can also be hardwired. Herein the term "processor" is used to refer generically to any device that can process game play instructions in accordance with game play rules and may include: a microprocessor, microcontroller, programmable logic device or other computational device, a general purpose computer (e.g. a PC) or a server.

A gaming system in the form of a stand alone gaming machine 10 is illustrated in Figure 2. The gaming machine 10 includes a console 12 having a display 14 on which are displayed representations of a game 16 that can be played by a player. A mid-trim 20 of the gaming machine 10 houses a bank of buttons 22 for enabling a player to interact with the gaming machine, in particular during game play. The mid-trim 20 also houses a credit input mechanism 24 which in this example includes a coin input chute 24A and a bill collector 24B. Other credit input mechanisms may also be employed, for example, a card reader for reading a smart card, debit card or credit card. A player marketing module (not shown) having a reading device may also be provided for the purpose of reading a player tracking device, for example as part of a loyalty program. The player tracking device may be in the form of a card, flash drive or any other portable storage medium capable of being read by the reading device.

A top box 26 may carry artwork 28, including for example pay tables and details of bonus awards and other information or images relating to the game. Further artwork and/or

2026201485 26 Feb 2026

information may be provided on a front panel 29 of the console 12. A coin tray 30 is mounted beneath the front panel 29 for dispensing cash payouts from the gaming machine 10.

5 The display 14 shown in Figure 2 is in the form of a video display unit, particularly a cathode ray tube screen device. Alternatively, the display 14 may be a liquid crystal display, plasma screen, any other suitable video display unit, or the visible portion of an electromechanical device. The top box 10 26 may also include a display, for example a video display unit, which may be of the same type as the display 14, or of a different type.

Figure 3 shows a block diagram of operative components of a 15 typical gaming machine which may be the same as or different to the gaming machine of Figure 2.

The gaming machine 100 includes a game controller 101 having a processor 102. Instructions and data to control operation of 20 the processor 102 are stored in a memory 103, which is in data communication with the processor 102. Typically, the gaming machine 100 will include both volatile and non-volatile memory and more than one of each type of memory, with such memories being collectively represented by the memory 103.

25 The gaming machine has hardware meters 104 for purposes including ensuring regulatory compliance and monitoring player credit, an input/output (I/O) interface 105 for communicating with peripheral devices of the gaming machine 100. The 30 input/output interface 105 and/or the peripheral devices may be intelligent devices with their own memory for storing associated instructions and data for use with the input/output interface or the peripheral devices. A random number generator module 113 generates random numbers for use by the 35 processor 102. Persons skilled in the art will appreciate that the reference to random numbers includes pseudo-random numbers.

In the example shown in Figure 3, a player interface 120 40 includes peripheral devices that communicate with the game

26 Feb 2026

2026201485

controller 101 comprise one or more displays 106, a touch screen and/or buttons 107, a card and/or ticket reader 108, a printer 109, a bill acceptor and/or coin input mechanism 110 and a coin output mechanism 111. Additional hardware may be included as part of the gaming machine 100, or hardware may be omitted as required for the specific implementation.

In addition, the gaming machine 100 may include a communications interface, for example a network card 112. The network card may, for example, send status information, accounting information or other information to a central controller, server or database and receive data or commands from the central controller, server or database.

Figure 4 shows a block diagram of the main components of an exemplary memory 103. The memory 103 includes RAM 103A, EPROM 103B and a mass storage device 103C. The RAM 103A typically temporarily holds program files for execution by the processor 102 and related data. The EPROM 103B may be a boot ROM device and/or may contain some system or game related code. The mass storage device 103C is typically used to store game programs, the integrity of which may be verified and/or authenticated by the processor 102 using protected code from the EPROM 103B or elsewhere.

It is also possible for the operative components of the gaming machine 100 to be distributed, for example input/output devices 106, 107, 108, 109, 110, 111 to be provided remotely from the game controller 101.

Figure 5 shows a gaming system 200 in accordance with an alternative embodiment. The gaming system 200 includes a network 201, which for example may be an Ethernet network. Gaming machines 202, shown arranged in three banks 203 of two gaming machines 202 in Figure 5, are connected to the network 201. The gaming machines 202 provide a player operable interface and may be the same as the gaming machines 10, 100 shown in Figures 2 and 3, or may have simplified functionality depending on the requirements for implementing game play.

While banks 203 of two gaming machines are illustrated in

2026201485 26 Feb 2026

Figure 5, banks of one, three or more gaming machines are also envisaged.

5 One or more displays 204 may also be connected to the network 201. For example, the displays 204 may be associated with one or more banks 203 of gaming machines. The displays 204 may be used to display representations associated with game play on the gaming machines 202, and/or used to display other representations, for example promotional or informational  
10 material.

15 In a thick client embodiment, game server 205 implements part of the game played by a player using a gaming machine 202 and the gaming machine 202 implements part of the game. With this embodiment, as both the game server and the gaming device implement part of the game, they collectively provide a game controller. A database management server 206 may manage storage of game programs and associated data for downloading or access by the gaming devices 202 in a database 206A.  
20 Typically, if the gaming system enables players to participate in a Jackpot game, a Jackpot server 207 will be provided to perform accounting functions for the Jackpot game. A loyalty program server 212 may also be provided.

25 In a thin client embodiment, game server 205 implements most or all of the game played by a player using a gaming machine 202 and the gaming machine 202 essentially provides only the player interface. With this embodiment, the game server 205 provides the game controller. The gaming machine will receive  
30 player instructions, pass these to the game server which will process them and return game play outcomes to the gaming machine for display. In a thin client embodiment, the gaming machines could be computer terminals, e.g. PCs running software that provides a player interface operable using  
35 standard computer input and output components.

Servers are also typically provided to assist in the administration of the gaming network 200, including for example a gaming floor management server 208, and a licensing  
40 server 209 to monitor the use of licenses relating to

2026201485 26 Feb 2026

particular games. An administrator terminal 210 is provided to allow an administrator to run the network 201 and the devices connected to the network.

5 The gaming system 200 may communicate with other gaming systems, other local networks, for example a corporate network, and/or a wide area network such as the Internet, for example through a firewall 211.

10 Persons skilled in the art will appreciate that in accordance with known techniques, functionality at the server side of the network may be distributed over a plurality of different computers. For example, elements may be run as a single "engine" on one server or a separate server may be provided.

15 For example, the game server 205 could run a random generator engine. Alternatively, a separate random number generator server could be provided. Further, persons skilled in the art will appreciate that a plurality of games servers could be provided to run different games or a single game server may  
20 run a plurality of different games as required by the terminals.

Persons skilled in the art will also appreciate that the method of the embodiment could be embodied in program code  
25 which can be executed by a processor to implement the game controller 60. The program code could be supplied in a number of ways, for example on a computer readable medium, such as a disc or a memory (for example, that could replace part of memory 103) or as a data signal (for example, by downloading  
30 it from a server).

With reference to Figure 6, the embodiment of the invention provides at least one symbol as shown in Figure 6 which comprises a visible symbol and a hidden symbol. In Figure 6,  
35 both the hidden and visible symbol are shown for illustrative purposes. However, the symbol 910 as shown in Figure 7 when actually viewed in real life would only show the numeral 10 with the X3 being hidden underneath the numeral 10 and also any background behind the numeral 10.

40

2026201485 26 Feb 2026

Figure 8 shows an overlay in the form of a transparent window 12 which can be overlaid on the symbol 910 so that the hidden symbol X3 is visible.

5 In one particular embodiment of the invention the numeral 10 and the symbol 910 may be blue in colour and the hidden symbol X3 may be red in colour and disguised behind the numeral 10 and the background of numeral 10 as previously mentioned.

10 The transparent window 912 is a transparent blue window so that when the transparent window 912 is overlaid on the symbol 910, the blue numeral 10 effectively disappears thereby making the red X3 symbol visible. The X3 symbol designates a win which results in a payout, or an additional payout to a  
15 player.

With reference to Figure 9 and Figure 11, a display 16 of a gaming machine is shown which comprises five reels 916a to 916e forming three rows 915a, 915b and 915c in a conventional  
20 five by three array. The symbols 910 are randomly generated by a random number generator selecting stop positions for each of a plurality of reels and are displayed as a video display on display 16. Typically, the reels 916a to 916e "spin" by moving the symbols 910 downwardly in Figure 9 to give the  
25 appearance of a spinning reel and are stopped in turn to form the display 16. When a player plays the game, a player will normally insert coins or other forms of payment to commence a game and will spin the reels to bring up the display 16. In accordance with the rules of the game, a win may be determined  
30 based on the display. For example, the two symbols 910 in row 915a may result in a payout to the player.

The player also has the option of selecting whether the player will pay all three rows 915a to 915c shown in Figure 9 or only  
35 one or two of those rows. There may also be other selections that the player can make when placing a wager, for example more win lines to select or the player may select reels rather than win lines.

40 When the requirements for use of the transparent window are

2026201485 26 Feb 2026

met, transparent window 912 is generated and is located randomly over at least one of the symbols 910 to determine whether that symbol contains a hidden symbol, if so an additional payout will occur. In alternative embodiments, the position is selected by the player or the position is predetermined. In another embodiment, the transparent window could cover a plurality of symbols. For example, it could be represented as a curtain.

Thus, according to the embodiment of the invention, the display of symbols shown in Figure 9 includes a hidden symbol 910'. The rules of the game determine whether a win occurs. As previously mentioned, the three tens in line 915a result in a win which is paid to the player.

The transparent window 912 is then overlaid on one or more of the reels as shown in Figure 10 and is spun and stopped randomly. If as shown in Figure 10 the transparent window 912 reveals a hidden symbol such as X3 in Figure 10, three times the payout previously provided is paid to the player. Thus, the player has a first chance to win based on the display in Figure 16 and a second chance once the window 912 is brought into play.

In one embodiment as shown in Figure 10, two separate overlay windows are used and overlay two of the reel strips of reels 16b and 16c in Figure 10. The overlay window marked 912' in Figure 10 which overlays the reel 16c does not result in any win because no hidden symbol is revealed.

In one embodiment of the invention, the transparent window 912 may comprise an overlay reel strip on two or more of the reels 16a to 16e and may be spun and stopped in a position over the symbols on two or more of the reels 16a to 16e.

The transparent window 912 can be bought into play automatically when a player reaches a certain stage of the game, in response to a trigger condition being met, in response to a purchase by a player, or randomly at some stage of a game.

26 Feb 2026

2026201485

In another embodiment, rather than provide the transparent window 912 as a transparent window on an overlay on one of the reels, the transparent window 912 may be a roaming window  
5 which simply remains static as shown in Figure 9 or moves around the display 16, and then moves randomly to locate on one of the symbols 910.

The transparent windows 912 may be restricted to an individual  
10 reel strip formed by the periphery of one of the reels 916a to 916d or may be an overlay reel strip which overlays two or more of the reels 916a to 916e.

Figure 11 is a flow chart explaining operation of an  
15 embodiment and Figure 12 is a functional modular block diagram illustrating the operation of the embodiment. In Random number generators 113 generate the symbols 910 which form the display 16 by selecting stopping positions for each of a plurality of reels. When the transparent window is to be used  
20 1125. The random number generators 113 also select the position at which the transparent window 912 will stop and overlay one of the symbols 910. After a game is started 1105, the reels strips defining symbols are spun 1110 by module 513, and the symbols selected by the random numbered generators are  
25 provided by display reel module 507 for display on the display 16. The module 514 determines if the transparent window is to be used 1125 based on the rules of the game. The position 1130 for the transparent window is selected if appropriate under control of transparent window module 505 such that the  
30 window is moved to that position under control of display module 507. In embodiments, where the transparent window is spun, the spin module 515 spins the transparent window and stops the window at one of the symbols on display 16. Wins are determined 1115, 1120 by the evaluation module 502 based  
35 on the original display and then the modified display with the overlay window 912. In one embodiment, wins are determined by storing the position of the symbols in Figure 9, in particular those which have hidden symbols so that when the stop position of the transparent window is determined, that position is  
40 recorded by module 512. If there is a match between the

2026201485 26 Feb 2026

position of the transparent window 512 and a hidden symbol in the spun display recorded by module 511, then the win previously provided to the player is modified in accordance with the hidden symbol. This may pay 1140 a multiplier such as three times the payout 1120 previously awarded or some other additional reward to the player. The module 501 allows the user to choose whether one, two or three win lines are being played. Persons skilled in the art will appreciate that in other embodiments, there may only be a single pay - i.e. pays are made only after the transparent window has been positioned.

Whilst in the embodiment described the display is in the form of a video display which simulates the movement of reels 916a to 916d by virtue of a video display, the display 16 could be a mechanical reel system in which reels are spun by a motor. In this embodiment, the overlay window 912 would comprise an overlay strip on one or more of the reels which is movable independently of the reel strips containing the symbols 910.

It is to be understood that, if any prior art publication is referred to herein, such reference does not constitute an admission that the publication forms a part of the common general knowledge in the art, in Australia or any other country.

In the claims which follow and in the preceding description of the invention, except where the context requires otherwise due to express language or necessary implication, the word "comprise" or variations such as "comprises" or "comprising" is used in an inclusive sense, i.e. to specify the presence of the stated features but not to preclude the presence or addition of further features in various embodiments of the invention.

THE CLAIMS DEFINING THE INVENTION ARE AS FOLLOWS:

1. A gaming machine comprising:
  - a plurality of reel strips including a plurality of first reel strips, at least one of the first reel strips having a hidden symbol and at least one, second overlay reel strip comprising an overlay;
  - a player interface comprising a display for displaying game outcomes;
  - a random number generator; and
  - a game controller arranged to:
    - randomly select a plurality of symbols from the first reel strips by using the random number generator to select stopping positions for each of the plurality of first reel strips;
    - display the selected symbols of the first reel strips with the display; and
    - randomly select, using the random number generator, a stopping position for each at least one second overlay reel strip comprising an overlay,
  - wherein responsive to the overlay being located on a selected hidden symbol, the hidden symbol is made visible on the display but otherwise the hidden symbol remains hidden, and
  - the game controller makes an award that is modified in accordance with the hidden symbol upon the hidden symbol being made visible.
  
2. The gaming machine of claim 1, wherein the overlay comprises a transparent window of a predetermined colour and the hidden symbol is a different colour to the predetermined colour, the visible symbol being the same colour as the predetermined colour.
  
3. The gaming machine of claim 5 or claim 6, wherein there are a plurality of second, overlay reel strips.

4. The gaming machine of claim 5, wherein the display includes the visible part of a mechanical device and the first reel strips and each second, overlay reel strip are components of a mechanical reel system.

2026201485 26 Feb 2026

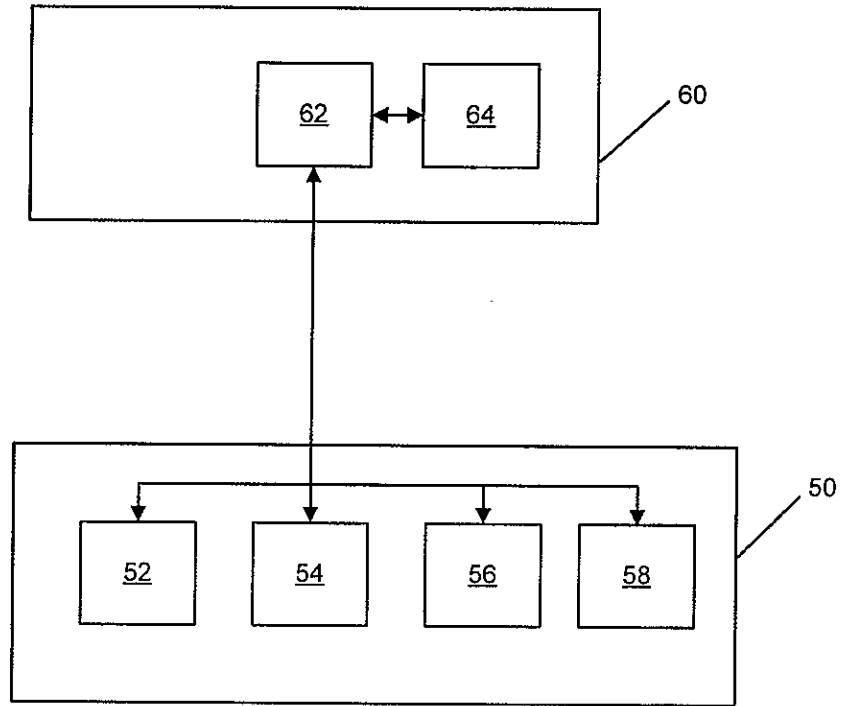

Figure 1

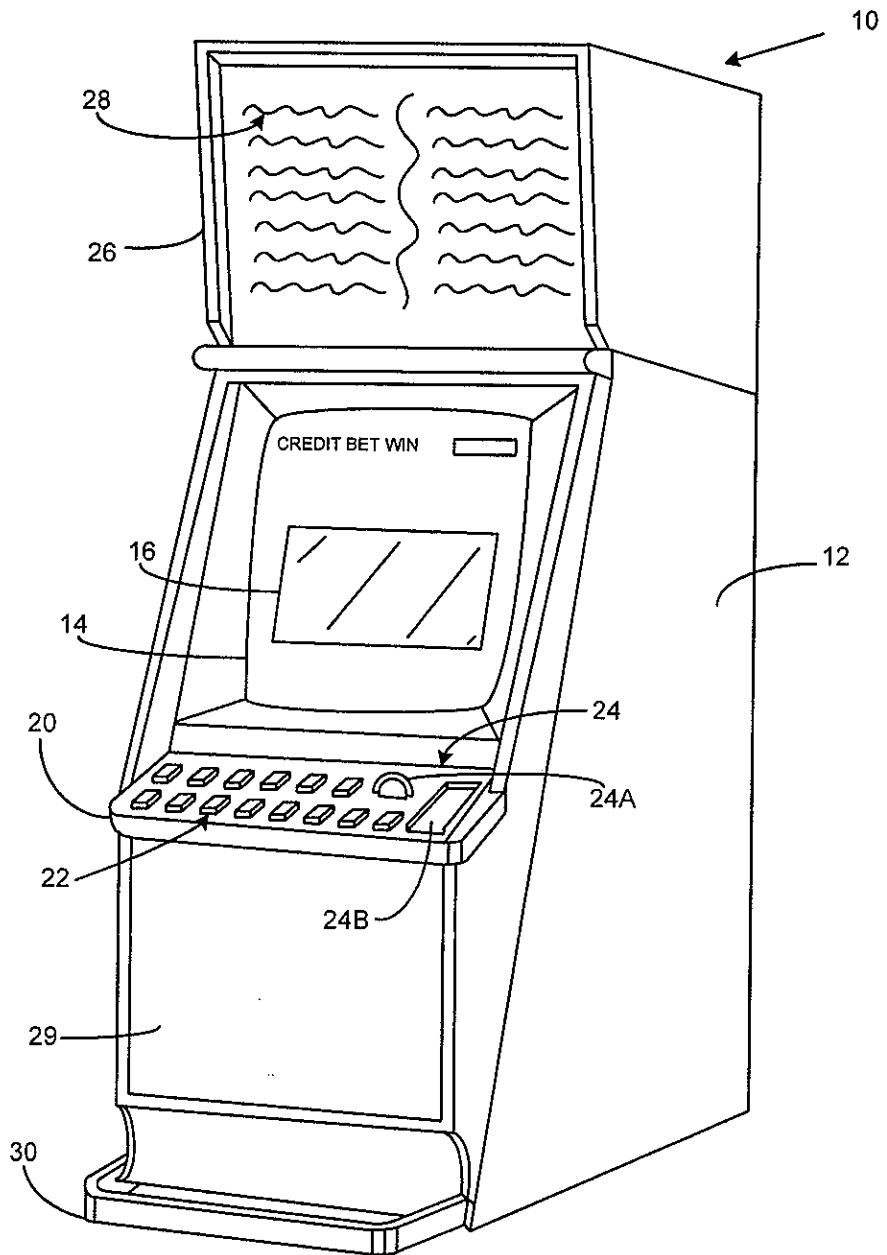

Figure 2

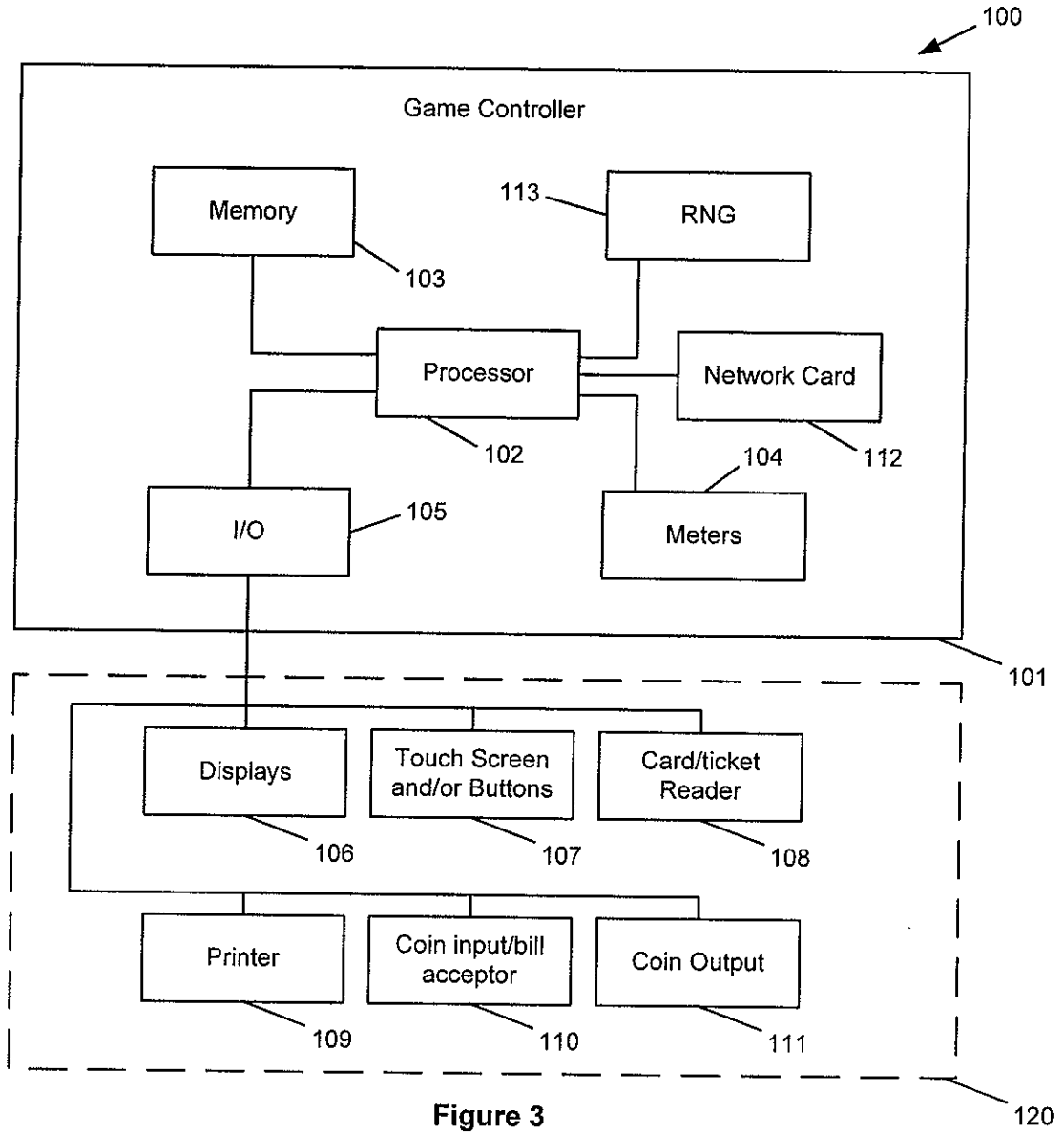

Figure 3

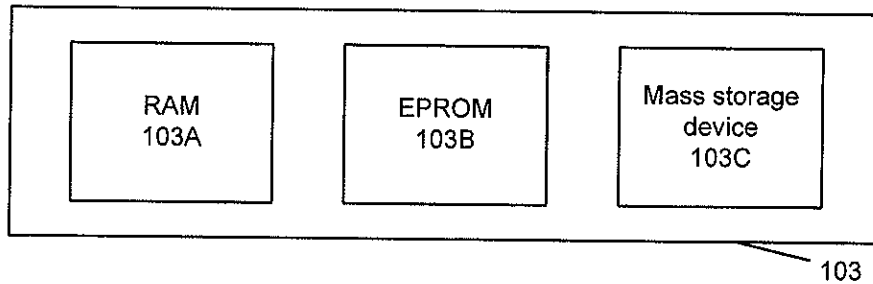

Figure 4

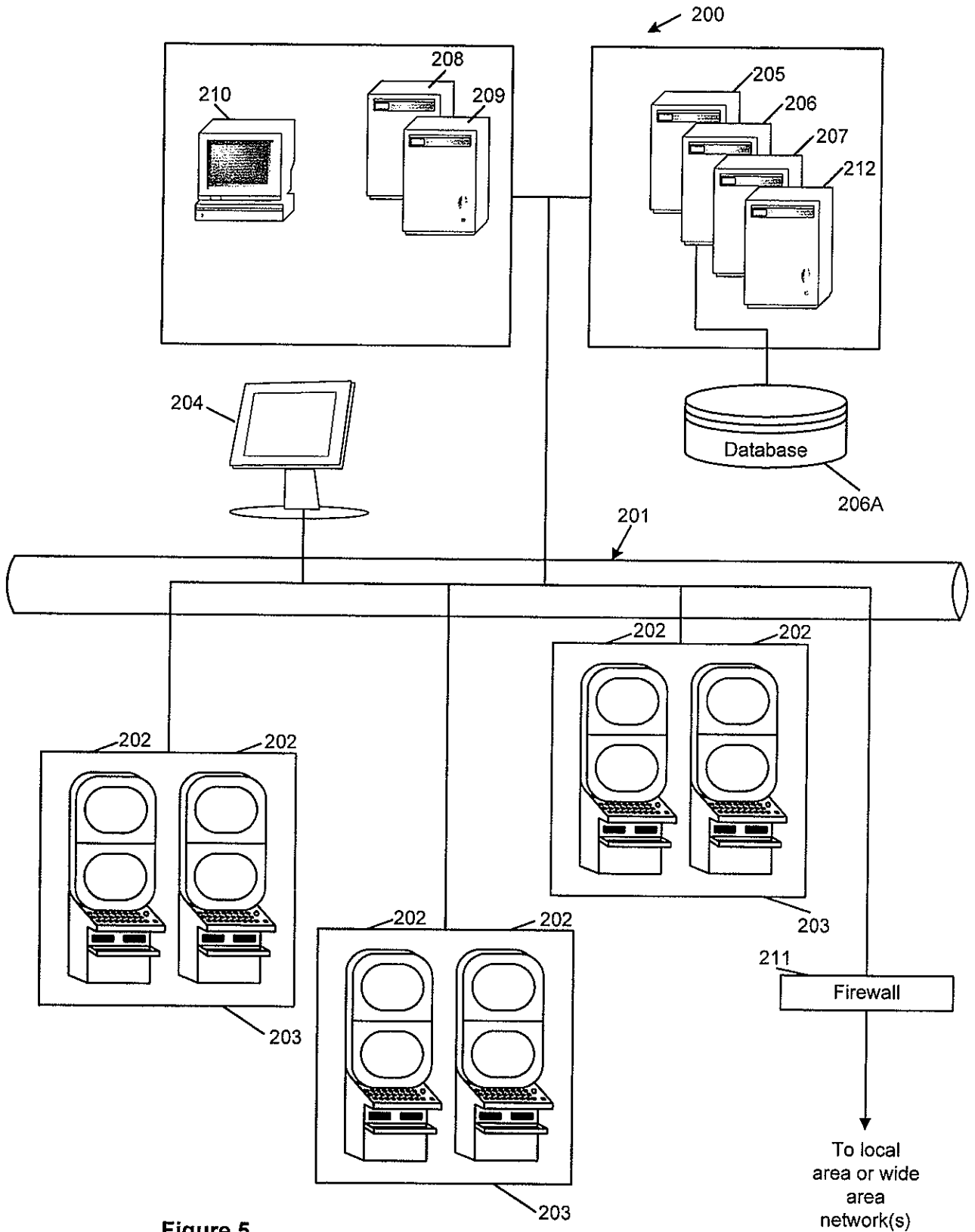

Figure 5

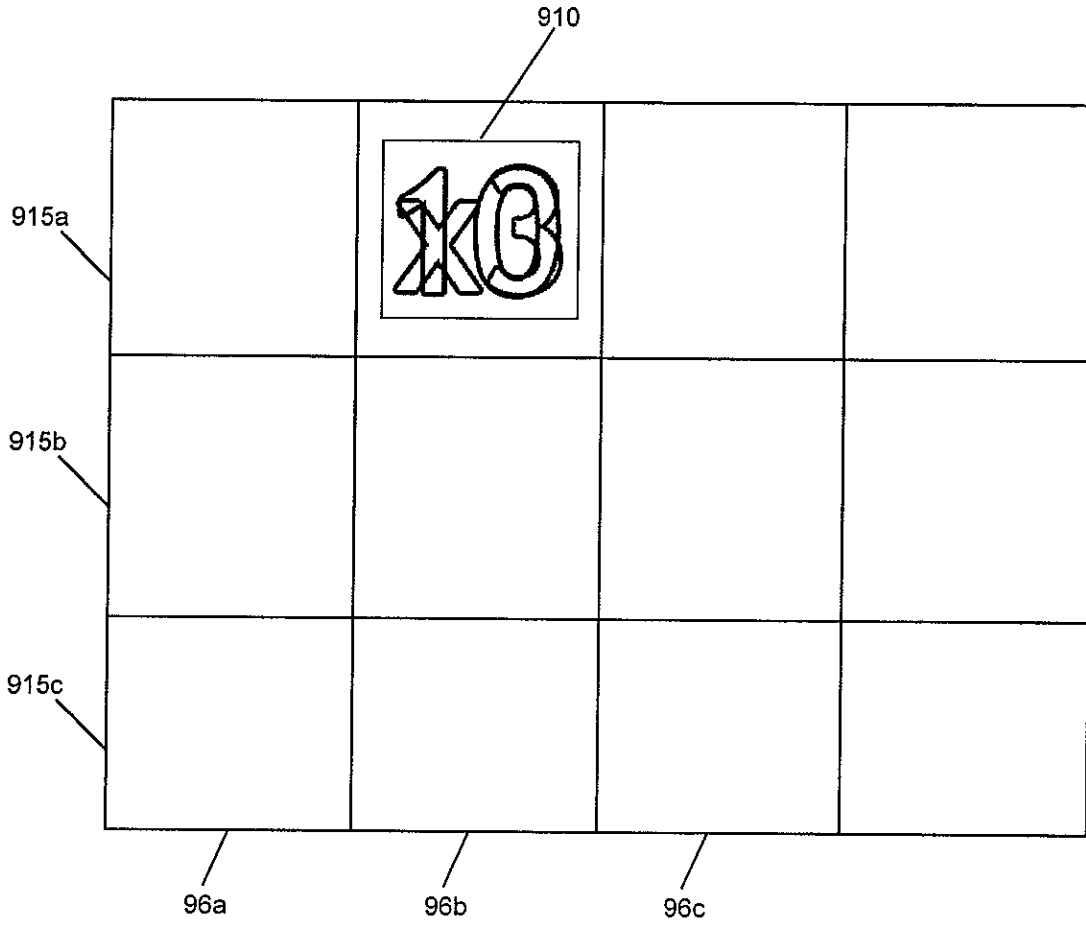

Figure 6

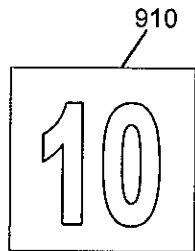

Figure 7

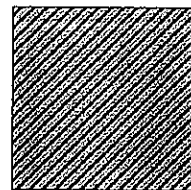

Figure 8

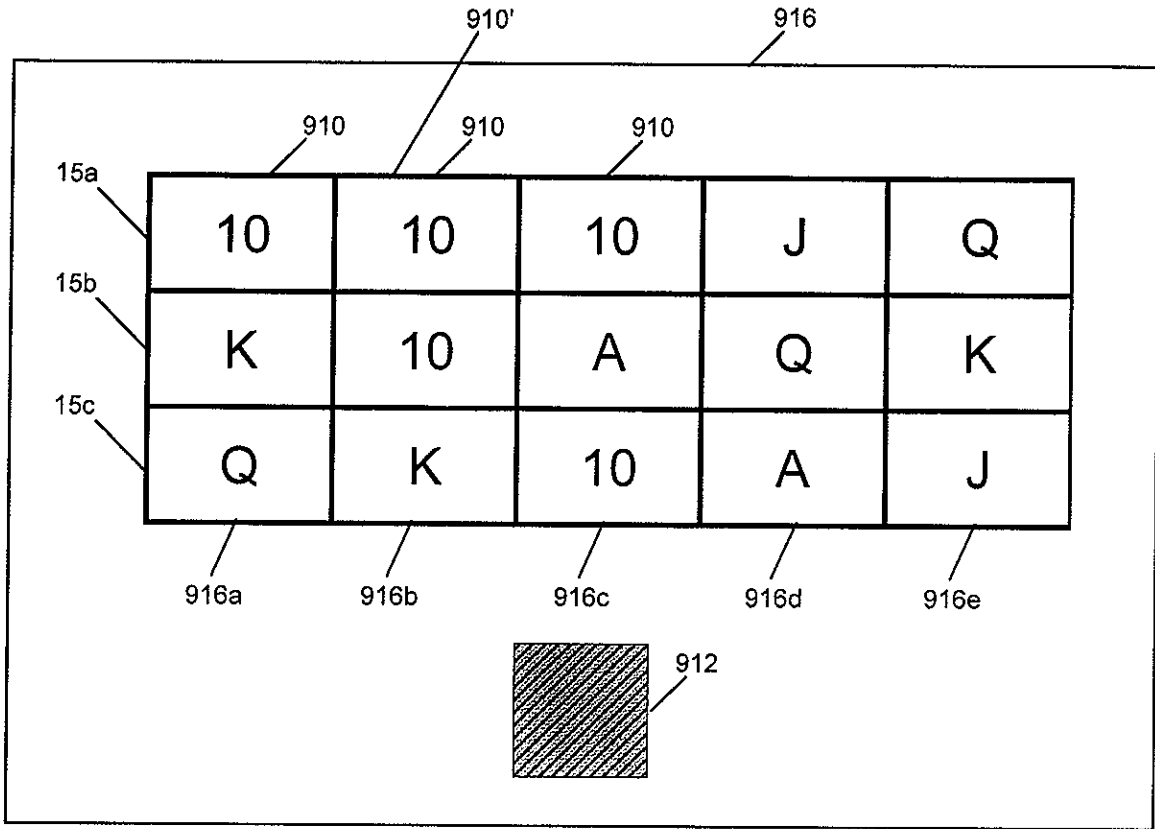

Figure 9

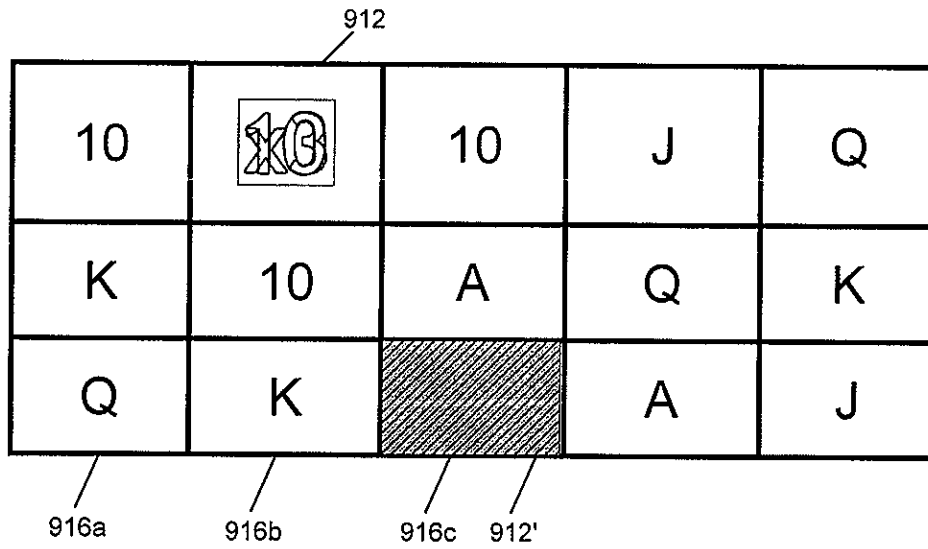

Figure 10

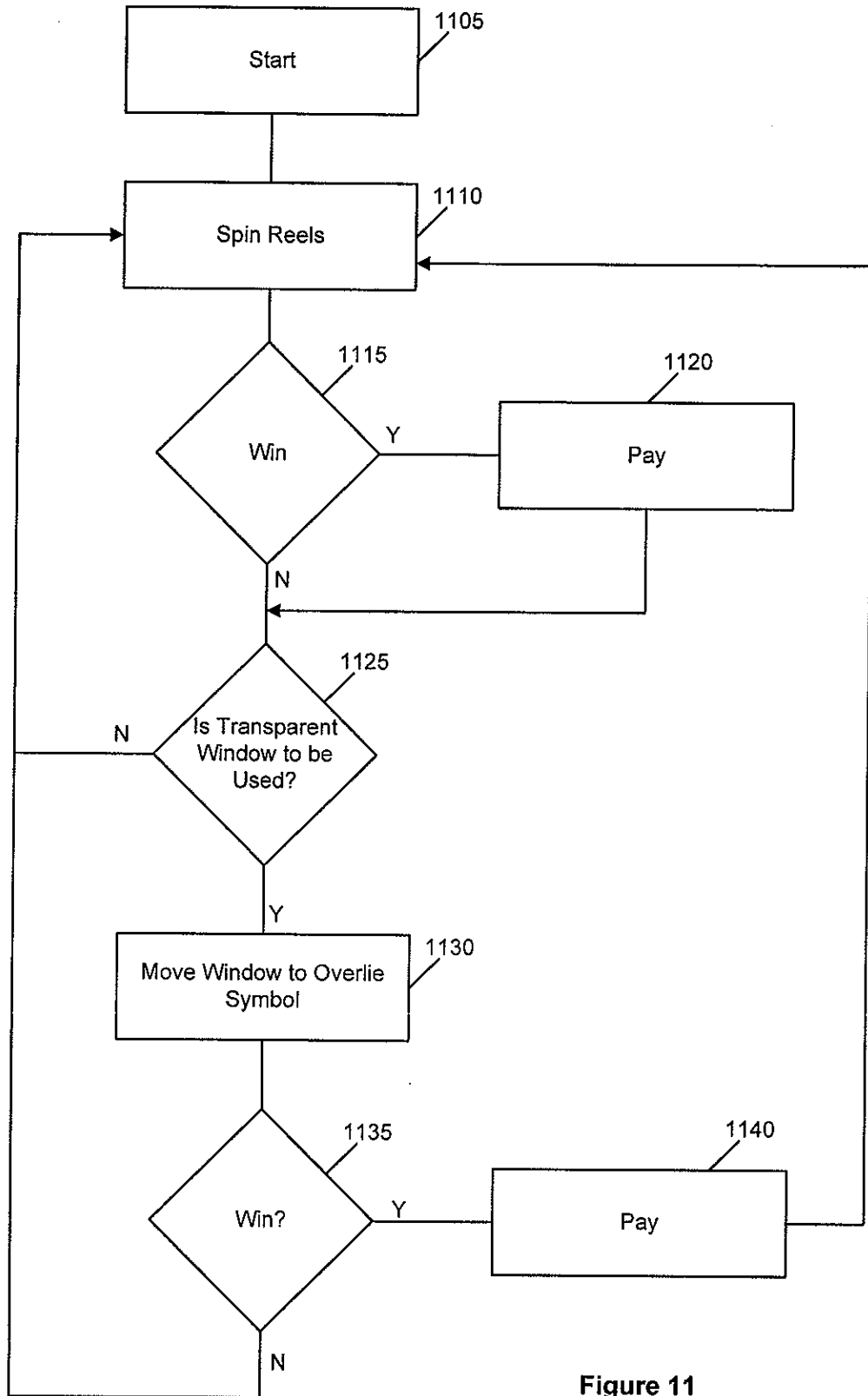

Figure 11

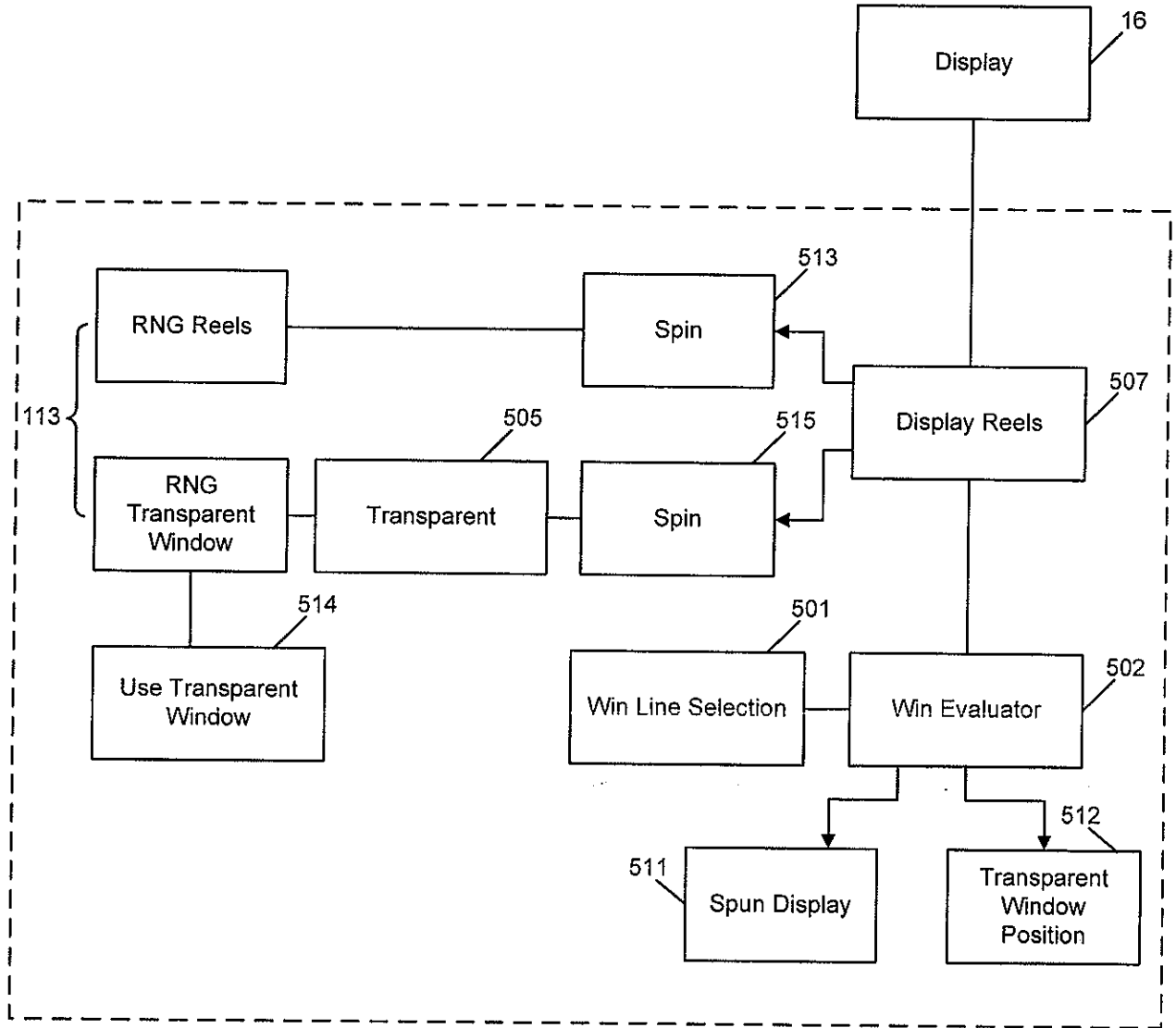

Figure 12