

(12) STANDARD PATENT APPLICATION (11) Application No. AU 2026201531 A1
(19) AUSTRALIAN PATENT OFFICE

(54) Title
Stimulation apparatus

(51) International Patent Classification(s)
A61N 1/00 (2006.01) **A61N 1/372** (2006.01)
A61N 1/18 (2006.01)

(21) Application No: **2026201531** (22) Date of Filing: **2026.02.27**

(43) Publication Date: **2026.03.19**

(43) Publication Journal Date: **2026.03.19**

(62) Divisional of:
2020298574

(71) Applicant(s)
Nalu Medical, Inc.

(72) Inventor(s)
BUDDHA, Rushidev;MISHRA, Lakshmi Narayan;FITZGERALD, Charlotte;O'CONNELL, Casey James;FREER, Paul;PALMER, Logan;HARTLEY, Lee Fason;PATEL, Ayesha;JOSHI, Manohar Diwakar;PIVONKA, Daniel M.;LAN, Xinting;SIRPATIL, Brijesh;LINDEN, Christopher;TENDULKAR, Sameer

(74) Agent / Attorney
Spruson & Ferguson, GPO Box 3898, Sydney, NSW, 2001, AU

ABSTRACT

A medical apparatus for a patient comprises an external system and an implantable system. The external system is configured to transmit one or more transmission signals, each transmission signal comprising at least power or data. The implantable system is configured to receive the one or more transmission signals from the external system, and to deliver stimulation energy to the patient. Methods of delivering stimulation energy are also provided.

STIMULATION APPARATUS

CROSS-REFERENCE

[1] The present application is a divisional application of Australian Patent Application No 2020298574, which entered national phase on 14 January 2022 in Australia off PCT application PCT/US2020/040766, which was filed on 2 July 2020, claims priority to: United States Provisional Application Serial Number 62/869,985, titled "Stimulation Apparatus", filed July 2, 2019 [Docket nos. 47476-715.101; NAL-021-PR1]; and United States Provisional Application Serial Number 62/894,077, titled "Stimulation Apparatus", filed August 30, 2019 [Docket nos. 47476-715.102; NAL-021-PR2]; the contents of each of which is incorporated herein by reference in its entirety for all purposes.

Related Applications

[2] This application is related to: United States Patent Application Serial Number 14/975,358, titled "Method and Apparatus for Minimally Invasive Implantable Modulators", filed December 18, 2015 [Docket nos. 47476.703.301; NAL-005-US]; United States Patent Application Serial Number 15/664,231, titled "Medical Apparatus Including an Implantable System and an External System ", filed July 31, 2017 [Docket nos. 47476-706.301; NAL-011-US]; United States Patent Application Serial Number 15/916,023, titled "Apparatus for Peripheral or Spinal Stimulation ", filed March 8, 2018 [Docket nos. 47476-707.301; NAL-012-US]; United States Patent Application Serial Number 16/104,829, titled "Apparatus with Enhanced Stimulation Waveforms", filed August 17, 2018 [Docket nos. 47476-708.301; NAL-014-US]; United States Patent Application Serial Number 16/111,868, titled "Devices and Methods for Positioning External Devices in Relation to Implanted Devices ", filed August 24, 2018 [Docket nos. 47476-709.301; NAL-016-US]; United States Patent Application Serial Number 16/120,139, titled "Methods and Systems for Insertion and Fixation of Implantable Devices ", filed August 31, 2018 [Docket nos. 47476-710.301; NAL-013-US]; United States Patent Application Serial Number 16/222,959, titled "Methods and Systems for Treating Pelvic Disorders and Pain Conditions ", filed December 17, 2018 [Docket nos. 47476-711.301; NAL-017-US]; United States Patent Application Serial Number 16/266,822, titled "Method and Apparatus for Versatile Minimally Invasive Neuromodulators ", filed February 4, 2019 [Docket nos. 47476-704.302; NAL-007-US-CON1]; United States Patent Application Serial Number 16/408,989, titled "Method and Apparatus for Neuromodulation Treatments of Pain and Other Conditions ", filed May 10, 2019 [Docket nos. 47476.705.302; NAL-008-US-CON1]; United

States Patent Application Serial Number 16/453,917, titled “Stimulation Apparatus”, filed June 26, 2019 [Docket nos. 47476-712.301; NAL-015-US]; United States Patent Application Serial Number 16/505,425, titled "Wireless Implantable Sensing Devices ", filed July 8, 2019 [Docket nos. 10220-728.300; NAL-006-US-CON1]; United States Patent Application Serial Number 16/539,977, titled “Apparatus with Sequentially Implanted Stimulators”, filed August 13, 2019 [Docket nos. 47476-713.301; NAL-019-US]; United States Patent Application Serial Number 16/672,921, titled “Stimulation Apparatus”, filed November 4, 2019 [Docket nos. 47476-714.301; NAL-020-US]; United States Provisional Application Serial Number 62/910,685, titled “Stimulation Apparatus”, filed October 4, 2019 [Docket nos. 47476-715.103; NAL-021-PR3]; United States Provisional Application Serial Number 62/933,184, titled “Stimulation Apparatus”, filed November 8, 2019 [Docket nos. 47476-715.104; NAL-021-PR4]; United States Provisional Application Serial Number 62/952,717, titled “System with Implanted Conduit Tracking”, filed December 23, 2019 [Docket nos. 47476-716.101; NAL-022-PR1]; United States Provisional Application Serial Number 62/977,901, titled “Stimulation Apparatus”, filed February 18, 2020 [Docket nos. 47476-715.105; NAL-021-PR5]; United States Provisional Application Serial Number 62/988,281, titled “Stimulation Apparatus”, filed March 11, 2020 [Docket nos. 47476-714.301; NAL-021-PR6]; and United States Provisional Application Serial Number 63/042,293, titled “Systems with Implanted Conduit Tracking”, filed June 22, 2020 [Docket nos. 47476-717.101; NAL-023-PR1]; the contents of each of which is incorporated herein by reference in its entirety for all purposes.

BACKGROUND OF THE INVENTION

Field of the Invention

[3] The present invention relates generally to medical apparatus for a patient, and in particular, apparatus that deliver enhanced stimulation to effectively deliver a therapy while avoiding undesired effects.

Background

[4] Implantable devices that treat a patient and/or record patient data are known. For example, implants that deliver energy such as electrical energy, or deliver agents such as pharmaceutical agents are commercially available. Implantable electrical stimulators can be used to pace or defibrillate the heart, as well as modulate nerve tissue (e.g. to treat pain). Most implants are relatively large devices with batteries and long conduits, such as implantable leads configured to deliver electrical energy or implantable tubes (i.e. catheters) to deliver an agent.

These implants require a fairly invasive implantation procedure, and periodic battery replacement, which requires additional surgery. The large sizes of these devices and their high costs have prevented their use in a variety of applications.

[5] Nerve stimulation treatments have shown increasing promise recently, showing potential in the treatment of many chronic diseases including drug-resistant hypertension, motility disorders in the intestinal system, metabolic disorders arising from diabetes and obesity, and both chronic and acute pain conditions among others. Many of these implantable device configurations have not been developed effectively because of the lack of miniaturization and power efficiency, in addition to other limitations.

[6] There is a need for apparatus, systems, devices and methods that provide one or more implantable devices and are designed to provide enhanced treatment of pain and other enhanced benefits.

SUMMARY

[7] According to an aspect of the present inventive concepts, a medical apparatus for a patient comprises: an external system and an implantable system. The external system is configured to transmit one or more transmission signals, each transmission signal comprising at least power or data. The implantable system is configured to receive the one or more transmission signals from the external system. The external system comprises a first external device comprising: at least one external antenna configured to transmit a first transmission signal to the implantable system, the first transmission signal comprising at least power or data; an external transmitter configured to drive the at least one external antenna; an external power supply configured to provide power to at least the external transmitter; and an external controller configured to control the external transmitter. The implantable system comprises a first implantable device comprising: at least one implantable antenna configured to receive the first transmission signal from the first external device; an implantable receiver configured to receive the first transmission signal from the at least one implantable antenna; at least one implantable stimulation element configured to deliver stimulation energy to the patient; an implantable controller configured to control the stimulation energy delivered to the at least one implantable stimulation element; an implantable energy storage assembly configured to provide power to an element selected from the group consisting of: the at least one implantable stimulation element; the implantable controller; the implantable receiver; and combinations thereof; and an implantable housing surrounding at least the implantable controller and the implantable receiver.

[8] In some embodiments, the at least one implantable antenna is positioned outside of the implantable housing, and the first implantable device further comprises: one or more

electrical components positioned within the implantable housing, and a tether that electrically connects the at least one implantable antenna to the one or more electrical components.

[9] In some embodiments, the first implantable device further comprises: one or more functional elements positioned outside of the implantable housing; one or more electrical components positioned within the implantable housing; and a tether that electrically connects the one or more functional elements to the one or more electrical components.

[10] In some embodiments, the first external device is configured to be positioned on the skin of the patient proximate the first implantable device, and the apparatus is configured to provide feedback regarding the quality of the positioning of the first external device.

[11] In some embodiments, the apparatus is configured to determine the quality of the first transmission signal by measuring the power consumption of the first external device. The position of the first external device can be configured to be optimized based on the determined quality of the first transmission signal. The apparatus can be further configured to determine the quality of the first transmission using a reference RSSI. The apparatus can compare the reference RSSI to a measured signal level of the first external device to determine the quality of the first transmission signal. The reference RSSI can comprise a reference selected from the group consisting of: a reference determined during a manufacturing process of the apparatus; a reference based on a characterization of a population of previously manufactured external devices and implantable devices; a reference determined during patient use of the apparatus; a reference determined during a calibration process; and combinations thereof. The apparatus can further comprise one or more user output components, and the apparatus can be further configured to provide feedback information related to the determined quality of the first transmission signal via the one or more user output components. The feedback information can comprise a good/bad assessment. The feedback information can comprise a multi-level assessment comprising three or more levels. The feedback information can be used to optimize the position of the first external device on the patient's skin. The feedback information can comprise the first external device skin position information that can be indicated by a changing graph, a changing quantity, and/or a changing tone.

[12] In some embodiments, the first implantable device further comprises: one or more implantable leads comprising the at least one stimulation element, and the apparatus further comprises a trialing interface comprising: an electronic assembly; a first connector; and an interface connector comprising a second connector removably attached to the first connector; and the interface connector is configured for operably and removably attaching to the one or more implantable leads. The electronic assembly can comprise a first detection circuitry and the

interface connector can comprise a second detection circuitry, and the trialing interface can be configured to detect proper connection of the first connector and the second connector via the first detection circuitry and the second detection circuitry. The trialing interface can be configured to repeatedly detect the proper connection. The second connector can comprise multiple contacts, and the second detection circuitry can comprise a connection of known resistance between two or more of the multiple contacts, and the electronic assembly can be configured to detect the proper connection based on the known resistance. The trialing interface can be configured to detect the proper connection without using a direct current signal. The trialing interface can be configured to detect the proper connection using an alternating current signal. The alternating current signal can comprise a digital pulse, and the electronic assembly can be configured to detect a high state during the pulse and a low state after the pulse. The trialing interface can be configured to repeatedly detect the proper connection by repeatedly delivering the digital pulse. The trialing interface can be configured to detect the first connector and the second connector transitioning from a disconnected state to a connected state, and the apparatus can be configured to avoid full amplitude signal delivery to the patient at the time of the connection. The apparatus can be configured to deliver stimulation energy at a first level prior to the time of the connection, and to initiate a new stimulation delivery in which the amplitude level can be slowly ramped up after the time of the connection. The amplitude can be ramped up over a period of 1 second to 10 seconds.

[13] In some embodiments, the apparatus further comprises a charging device, and the first external device comprises multiple electrical contacts configured to electrically connect to the charging device to receive energy to recharge the external power supply. The first external device can further comprise switching circuitry configured as a passivation module that reduces corrosion of the multiple electrical contacts. The switching circuitry can be configured to remove voltage from the multiple electrical contacts when the first external device is not operably connected to the charging device. The switching circuitry can comprise a first transistor which detects that the first external device can be operably connected to the charging device. The first external device can be configured to detect an operable connection to the charging device. The first external device can be configured to at least limit transmissions of power and/or data to the first implantable device when the first external device is operably connected to the charging device. The first external device can be configured to enter a sleep state when the first external device is operably connected to the charging device.

[14] In some embodiments, the at least one stimulation element comprises multiple stimulation elements, and the first implantable device further comprises: one or more

implantable leads, each lead comprising two or more stimulation elements of the multiple stimulation elements, and the first implantable device does not comprise a monopolar return path for the delivery of the stimulation energy by the multiple stimulation elements. The first implantable device can be configured to be in a pseudo-monopolar mode, and to measure impedance of the multiple stimulation elements when in the pseudo-monopolar mode. The pseudo-monopolar mode can comprise a first stimulation element of the multiple stimulation elements being configured as a cathode, and the remaining of the multiple stimulation elements each being configured as an anode. The first implantable device can comprise a current source, and the impedance associated with the first stimulation element can be determined by measuring a resulting voltage pulse that can be generated at the first stimulation element when the current source delivers a current pulse to the first stimulation element. The pseudo-monopolar mode can comprise a second stimulation element of the multiple stimulation elements being configured as a cathode, and the remaining of the multiple stimulation elements each being configured as an anode. The impedance of the second stimulation element can be measured by measuring a resulting voltage pulse that is generated at the second stimulation element when the current source delivers a current pulse to the second stimulation element.

[15] In some embodiments, the at least one stimulation element comprises multiple stimulation elements, and the first implantable device is configured to detect a short between a first stimulation element and a second stimulation element. The first implantable device can further comprise a current source configured to deliver a current pulse to the first stimulation element while the first implantable device connects the remaining stimulation elements to ground, and the implantable device detects the short between the first stimulation element and the second stimulation element if the resulting voltage is below a threshold. The first implantable device can further comprise a current source configured to deliver a current pulse to the first stimulation element, and the implantable device detects the short between the first stimulation element and the second stimulation element if the resulting voltage is above a threshold.

[16] In some embodiments, the at least one stimulation element comprises multiple stimulation elements, and the first implantable device is configured to detect an open circuit at a stimulation element.

[17] In some embodiments, the apparatus is configured such that the one or more transmission signals are relatively unaffected by a rotational orientation of the first external device.

[18] In some embodiments, the at least one stimulation element is configured to deliver a sequence of monophasic pulses. The at least one stimulation element can comprise multiple stimulation elements configured to deliver stimulation energy to multiple tissue locations sequentially. The monophasic pulses can be sequenced within the stimulation interval per the pulse width and inter-pulse gaps for each tissue location.

[19] In some embodiments, the first implantable device is configured to increase compliance voltage and to perform passive charge recovery.

[20] The technology described herein, along with the attributes and attendant advantages thereof, will best be appreciated and understood in view of the following detailed description taken in conjunction with the accompanying drawings in which representative embodiments are described by way of example.

INCORPORATION BY REFERENCE

[21] All publications, patents, and patent applications mentioned in this specification are herein incorporated by reference to the same extent as if each individual publication, patent, or patent application was specifically and individually indicated to be incorporated by reference. The content of all publications, patents, and patent applications mentioned in this specification are herein incorporated by reference in their entirety for all purposes.

BRIEF DESCRIPTION OF THE DRAWINGS

[22] The foregoing and other objects, features and advantages of embodiments of the present inventive concepts will be apparent from the more particular description of preferred embodiments, as illustrated in the accompanying drawings in which like reference characters refer to the same or like elements. The drawings are not necessarily to scale, emphasis instead being placed upon illustrating the principles of the preferred embodiments.

[23] **Fig. 1** is a schematic anatomical view of a medical apparatus comprising an external system and an implantable system, consistent with the present inventive concepts.

[24] **Fig. 2** is a flow chart of a method for positioning an external device on the skin of a patient, consistent with the present inventive concepts.

[25] **Figs. 3A-D** are various views of a patient attachment device and an external device, consistent with the present inventive concepts.

[26] **Figs. 4A-B** are perspective views of an electronic assembly of an implantable device in unfolded and folded states, respectively, consistent with the present inventive concepts.

- [27] **Figs. 5A-H** are various views of an electronic assembly of an implantable device in various states of a folding process, consistent with the present inventive concepts.
- [28] **Figs. 6A-C** are a perspective, end, and side view, respectively, of a partially assembled portion of an implantable device, consistent with the present inventive concepts.
- [29] **Figs. 7A-C** are a perspective, top, and side view, respectively, of an implantable device including a connector for attaching to two leads, consistent with the present inventive concepts.
- [30] **Fig. 7D** is a top view of the end portion of the connector of Figs. 7A-C.
- [31] **Figs. 8A-C** are a perspective, side sectional, and perspective transparent view, respectively, of an anchoring element, consistent with the present inventive concepts.
- [32] **Fig. 9** is a top view of an electronic assembly of an implantable device, consistent with the present inventive concepts.
- [33] **Fig. 10** is an exploded view of an external device, consistent with the present inventive concepts.
- [34] **Figs. 11A-D** are a perspective top view, a side view, a side sectional view, and another side sectional view, respectively, of an interface assembly for operably attaching a trialing interface to two lead assemblies, consistent with the present inventive concepts.
- [35] **Figs. 12A-B** are a perspective view and a schematic view, respectively, of a stimulation apparatus comprising a trialing interface and a lead connector, consistent with the present inventive concepts.
- [36] **Figs. 13A-B** are perspective views and a top view, respectively, of an implantable device with a single lead, and an implantable device with dual leads, respectively, consistent with the present inventive concepts.
- [37] **Fig. 13C** is a top view of an implantable device with dual leads and separate implantation tools inserted into each lead, consistent with the present inventive concepts.
- [38] **Figs. 14A-B** are a perspective view and a top view, respectively, of the proximal portion of an implantable device with dual leads, consistent with the present inventive concepts.
- [39] **Figs. 15A-M** are a series of views of various implantation procedures for an implantable device, consistent with the present inventive concepts.
- [40] **Figs. 16A-B** are a side view of an introducer tool, and a magnified view of the distal portion of the introducer tool, respectively, consistent with the present inventive concepts.
- [41] **Figs. 17A-C** are various views of an external device and a charging device, consistent with the present inventive concepts.

- [42] **Fig. 17D** is a schematic view of charging circuitry for an external device, consistent with the present inventive concepts.
- [43] **Fig. 18** is a schematic view of a portion of an electronic assembly of an implantable device, consistent with the present inventive concepts.
- [44] **Fig. 19** is a block diagram of a TTAP system, consistent with the present inventive concepts.
- [45] **Figs. 20A-B** are schematic views of a power delivery and consumption arrangement of a stimulation apparatus, consistent with the present inventive concepts.
- [46] **Fig. 21** is a schematic view of a back-telemetry circuit of an implantable device, consistent with the present inventive concepts.
- [47] **Figs. 22A-F** are schematic views of various implantable device lead arrangements, consistent with the present inventive concepts.
- [48] **Fig. 23** is a graph of an amplitude modulation scheme, consistent with the present inventive concepts.
- [49] **Figs. 24A-B** are top views of an external device positioned on a patient in a first orientation, and a second orientation, respectively, consistent with the present inventive concepts.
- [50] **Fig. 25A** is a schematic view of a reconfigurable stimulation block portion of an electronic assembly of an implantable device, consistent with the present inventive concepts.
- [51] **Fig. 25B** is a diagram of a control input sequence, consistent with the present inventive concepts.
- [52] **Fig. 25C** is a schematic view of a portion of an electronic assembly of an implantable device, consistent with the present inventive concepts.
- [53] **Figs. 26A-C** are schematic views of a test fixture arrangement for testing an electronic assembly of an implantable device, consistent with the present inventive concepts.
- [54] **Figs. 27A-C** are a series of views of stimulations waveforms, consistent with the present inventive concepts.
- [55] **Figs. 28A-C** are schematic views of stimulation circuitry of an implantable device, consistent with the present inventive concepts.
- [56] **Figs. 28D-E** are views of stimulation and discharge waveforms, consistent with the present inventive concepts.
- [57] **Figs. 28F-G** are views of stimulation and discharge waveforms, as well as a chart of voltage across a DC blocking capacitor, consistent with the present inventive concepts.

DETAILED DESCRIPTION OF THE DRAWINGS

[58] The terminology used herein is for the purpose of describing particular embodiments and is not intended to be limiting of the inventive concepts. Furthermore, embodiments of the present inventive concepts may include several novel features, no single one of which is solely responsible for its desirable attributes or which is essential to practicing an inventive concept described herein. As used herein, the singular forms “a,” “an” and “the” are intended to include the plural forms as well, unless the context clearly indicates otherwise.

[59] It will be further understood that the words "comprising" (and any form of comprising, such as "comprise" and "comprises"), "having" (and any form of having, such as "have" and "has"), "including" (and any form of including, such as "includes" and "include") or "containing" (and any form of containing, such as "contains" and "contain") when used herein, specify the presence of stated features, integers, steps, operations, elements, and/or components, but do not preclude the presence or addition of one or more other features, integers, steps, operations, elements, components, and/or groups thereof.

[60] It will be understood that, although the terms first, second, third etc. may be used herein to describe various limitations, elements, components, regions, layers, and/or sections, these limitations, elements, components, regions, layers, and/or sections should not be limited by these terms. These terms are only used to distinguish one limitation, element, component, region, layer or section from another limitation, element, component, region, layer or section. Thus, a first limitation, element, component, region, layer or section discussed below could be termed a second limitation, element, component, region, layer or section without departing from the teachings of the present application.

[61] It will be further understood that when an element is referred to as being “on”, “attached”, “connected” or “coupled” to another element, it can be directly on or above, or connected or coupled to, the other element, or one or more intervening elements can be present. In contrast, when an element is referred to as being “directly on”, “directly attached”, “directly connected” or “directly coupled” to another element, there are no intervening elements present. Other words used to describe the relationship between elements should be interpreted in a like fashion (e.g. “between” versus “directly between,” “adjacent” versus “directly adjacent,” etc.). A first component (e.g. a device, assembly, housing or other component) can be “attached”, “connected” or “coupled” to another component via a connecting filament (as defined below). In some embodiments, an assembly comprising multiple components connected by one or more connecting filaments is created during a manufacturing process (e.g. pre-connected at the time of an implantation procedure of the apparatus of the present inventive concepts). Alternatively or

additionally, a connecting filament can comprise one or more connectors (e.g. a connectorized filament comprising a connector on one or both ends), and a similar assembly can be created by a user (e.g. a clinician) operably attaching the one or more connectors of the connecting filament to one or more mating connectors of one or more components of the assembly.

[62] It will be further understood that when a first element is referred to as being “in”, “on” and/or “within” a second element, the first element can be positioned: within an internal space of the second element, within a portion of the second element (e.g. within a wall of the second element); positioned on an external and/or internal surface of the second element; and combinations of one or more of these.

[63] Spatially relative terms, such as "beneath," "below," "lower," "above," "upper" and the like may be used to describe an element and/or feature's relationship to another element(s) and/or feature(s) as, for example, illustrated in the figures. It will be understood that the spatially relative terms are intended to encompass different orientations of the device in use and/or operation in addition to the orientation depicted in the figures. For example, if the device in a figure is turned over, elements described as "below" and/or "beneath" other elements or features would then be oriented "above" the other elements or features. The device can be otherwise oriented (e.g. rotated 90 degrees or at other orientations) and the spatially relative descriptors used herein interpreted accordingly.

[64] As used herein, the term "proximate" shall include locations relatively close to, on, in, and/or within a referenced component or other location.

[65] The term “and/or” where used herein is to be taken as specific disclosure of each of the two specified features or components with or without the other. For example, “A and/or B” is to be taken as specific disclosure of each of (i) A, (ii) B and (iii) A and B, just as if each is set out individually herein.

[66] The term “diameter” where used herein to describe a non-circular geometry is to be taken as the diameter of a hypothetical circle approximating the geometry being described. For example, when describing a cross section, such as the cross section of a component, the term “diameter” shall be taken to represent the diameter of a hypothetical circle with the same cross-sectional area as the cross section of the component being described.

[67] The terms “major axis” and “minor axis” of a component where used herein are the length and diameter, respectively, of the smallest volume hypothetical cylinder which can completely surround the component.

[68] The term “functional element” where used herein, is to be taken to include a component comprising one, two or more of: a sensor; a transducer; an electrode; an energy

delivery element; an agent delivery element; a magnetic field generating transducer; and combinations of one or more of these. In some embodiments, a functional element comprises a transducer selected from the group consisting of: light delivery element; light emitting diode; wireless transmitter; Bluetooth device; mechanical transducer; piezoelectric transducer; pressure transducer; temperature transducer; humidity transducer; vibrational transducer; audio transducer; speaker; and combinations of one or more of these. In some embodiments, a functional element comprises a needle, a catheter (e.g. a distal portion of a catheter), an iontophoretic element or a porous membrane, such as an agent delivery element configured to deliver one or more agents. In some embodiments, a functional element comprises one or more sensors selected from the group consisting of: electrode; sensor configured to record electrical activity of tissue; blood glucose sensor such as an optical blood glucose sensor; pressure sensor; blood pressure sensor; heart rate sensor; inflammation sensor; neural activity sensor; muscular activity sensor; pH sensor; strain gauge; accelerometer; gyroscope; GPS; respiration sensor; respiration rate sensor; temperature sensor; magnetic sensor; optical sensor; MEMs sensor; chemical sensor; hormone sensor; impedance sensor; tissue impedance sensor; body position sensor; body motion sensor; physical activity level sensor; perspiration sensor; patient hydration sensor; breath monitoring sensor; sleep monitoring sensor; food intake monitoring sensor; urine movement sensor; bowel movement sensor; tremor sensor; pain level sensor; orientation sensor; motion sensor; and combinations of one or more of these.

[69] The term “transducer” where used herein is to be taken to include any component or combination of components that receives energy or any input, and produces an output. For example, a transducer can include an electrode that receives electrical energy, and distributes the electrical energy to tissue (e.g. based on the size of the electrode). In some configurations, a transducer converts an electrical signal into any output, such as light (e.g. a transducer comprising a light emitting diode or light bulb), sound (e.g. a transducer comprising a piezo crystal configured to deliver ultrasound energy), pressure, heat energy, cryogenic energy, chemical energy, mechanical energy (e.g. a transducer comprising a motor or a solenoid), magnetic energy, and/or a different electrical signal (e.g. a Bluetooth or other wireless communication element). Alternatively or additionally, a transducer can convert a physical quantity (e.g. variations in a physical quantity) into an electrical signal. A transducer can include any component that delivers energy and/or an agent to tissue, such as a transducer configured to deliver one or more of: electrical energy to tissue (e.g. a transducer comprising one or more electrodes); light energy to tissue (e.g. a transducer comprising a laser, light emitting diode and/or optical component such as a lens or prism); mechanical energy to tissue (e.g. a transducer

comprising a tissue manipulating element); sound energy to tissue (e.g. a transducer comprising a piezo crystal); thermal energy to tissue (e.g. heat energy and/or cryogenic energy); chemical energy; electromagnetic energy; magnetic energy; and combinations of one or more of these.

[70] The term “transmission signal” where used herein is to be taken to include any signal transmitted between two components, such as via a wired or wireless communication pathway. For example, a transmission signal can comprise a power and/or data signal wirelessly transmitted between a component external to the patient and one or more components implanted in the patient. A transmission signal can include one or more signals transmitted using body conduction. Alternatively or additionally, a transmission signal can comprise reflected energy, such as energy reflected from any power and/or data signal.

[71] The term “data signal” where used herein is to be taken to include a transmission signal including at least data. For example, a data signal can comprise a transmission signal including data and sent between a component external to the patient and one or more components implanted in the patient. Alternatively, a data signal can comprise a transmission signal including data sent from an implanted component to one or more components external to the patient. A data signal can comprise a radiofrequency signal including data (e.g. a radiofrequency signal including both power and data) and/or a data signal sent using body conduction.

[72] The term “implantable” where used herein is to be taken to define a component which is constructed and arranged to be fully or partially implanted in a patient’s body and/or a component that has been fully or partially implanted in a patient. The term “external” where used herein is to be taken to define a component which is constructed and arranged to be positioned outside of the patient’s body.

[73] The terms “attachment”, “attached”, “attaching”, “connection”, “connected”, “connecting” and the like, where used herein, are to be taken to include any type of connection between two or more components. The connection can include an “operable connection” or “operable attachment” which allows multiple connected components to operate together such as to transfer information, power, and/or material (e.g. an agent to be delivered) between the components. An operable connection can include a physical connection, such as a physical connection including a connection between two or more: wires or other conductors (e.g. an “electrical connection”), optical fibers, wave guides, tubes such as fluid transport tubes, and/or linkages such as translatable rods or other mechanical linkages. Alternatively or additionally, an operable connection can include a non-physical or “wireless” connection, such as a wireless connection in which information and/or power is transmitted between components using

electromagnetic energy. A connection can include a connection selected from the group consisting of: a wired connection; a wireless connection; an electrical connection; a mechanical connection; an optical connection; a sound propagating connection; a fluid connection; and combinations of one or more of these.

[74] The term “connecting filament” where used herein is to be taken to define a filament connecting a first component to a second component. The connecting filament can include a connector on one or both ends, such as to allow a user to operably attach at least one end of the filament to a component. A connecting filament can comprise one or more elements selected from the group consisting of: wires; optical fibers; fluid transport tubes; mechanical linkages; wave guides; flexible circuits; and combinations of one or more of these. A connecting filament can comprise rigid filament, a flexible filament or it can comprise one or more flexible portions and one or more rigid portions.

[75] The term “connectorized” where used herein is to be taken to refer to a filament, housing or other component that includes one or more connectors (e.g. clinician or other user-attachable connectors) for operably connecting that component to a mating connector (e.g. of the same or different component).

[76] The terms “**stimulation parameter**”, “**stimulation signal parameter**” or “**stimulation waveform parameter**” where used herein can be taken to refer to one or more parameters of a stimulation waveform (also referred to as a stimulation signal). Applicable stimulation parameters of the present inventive concepts shall include but are not limited to: amplitude (e.g. amplitude of voltage and/or current); average amplitude; peak amplitude; frequency; average frequency; pulse width (also referred to as “pulse pattern on time”); period; phase; polarity; pulse shape; a duty cycle parameter (e.g. frequency, pulse width, and/or off time); inter-pulse gap (also referred to as “pulse pattern off time”, or “inter-pulse interval”); polarity; burst-on (also referred to as “dosage on”) period; burst-off (also referred to as “dosage off”) period; inter-burst period; pulse train; train-on period; train-off period; inter-train period; drive impedance; duration of pulse and/or amplitude level; duration of stimulation waveform; repetition of stimulation waveform; an amplitude modulation parameter; a frequency modulation parameter; a burst parameter; a power spectral density parameter; an anode/cathode configuration parameter; amount of energy and/or power to be delivered; rate of energy and/or power delivery; time of energy delivery initiation; method of charge recovery; and combinations of one or more of these. A stimulation parameter can refer to a single stimulation pulse, multiple stimulation pulses, or a portion of a stimulation pulse. The term “**amplitude**” where used herein can refer to an instantaneous or continuous amplitude of one or more stimulation pulses (e.g. the

instantaneous voltage level or current level of a pulse). The term “**pulse**” where used herein can refer to a period of time during which stimulation energy is relatively continuously being delivered. In some embodiments, stimulation energy delivered during a pulse comprises energy selected from the group consisting of: electrical energy; magnetic energy; electromagnetic energy; light energy; sound energy such as ultrasound energy; mechanical energy such as vibrational energy; thermal energy such as heat energy or cryogenic energy; chemical energy; and combinations of one or more of these. In some embodiments, stimulation energy comprises electrical energy and a pulse comprises a phase change in current and/or voltage. In these embodiments, an “**inter-phase gap**” can be present within a single pulse. The term inter-phase gap where used herein can refer to a period of time between two portions of a pulse comprising a phase change during which zero energy or minimal energy is delivered. The term “**quiescent period**” where used herein can refer to a period of time during which zero energy or minimal energy is delivered (e.g. insufficient energy to elicit an action potential and/or other neuronal response). The term “**inter-pulse gap**” where used herein can refer to a quiescent period between the end of one pulse to the onset of the next (sequential) pulse. The terms “**pulse train**” or “**train**” where used herein can refer to a series of pulses. The terms “**burst**”, “**burst of pulses**” or “**burst stimulation**” where used herein can refer to a series of pulse trains, each separated by a quiescent period. The term “**train-on period**” where used herein can refer to a period of time from the beginning of the first pulse to the end of the last pulse of a single train. The term “**train-off period**” where used herein can refer to a quiescent period between the end of one train and the beginning of the next train. The term “**burst-on period**” where used herein can refer to a period of time from the beginning of the first pulse of the first train to the end of the last pulse of the last train of a single burst. The term “**burst-off period**” where used herein can refer to a quiescent period between the end of one burst and the beginning of the next burst. The term “**inter-train period**” where used herein can refer to a quiescent period between the end of one train and the beginning of the next train. The term “**inter-burst period**” where used herein can refer to a quiescent period between the end of one burst and the beginning of the next burst. The term “**train envelope**” where used herein can refer to a curve outlining the amplitude extremes of a series of pulses in a train. The term “**burst envelope**” where used herein can refer to a curve outlining the amplitude extremes of a series of pulses in a burst. The term “**train ramp duration**” where used herein can refer to the time from the onset of a train until its train envelope reaches a desired target magnitude. The term “**burst ramp duration**” where used herein can refer to the time from the onset of a burst until its burst envelope reaches a desired target magnitude.

[77] It is appreciated that certain features of the invention, which are, for clarity, described in the context of separate embodiments, may also be provided in combination in a single embodiment. Conversely, various features of the invention which are, for brevity, described in the context of a single embodiment, may also be provided separately or in any suitable sub-combination. For example, it will be appreciated that all features set out in any of the claims (whether independent or dependent) can be combined in any given way.

[78] The present inventive concepts include a medical apparatus and clinical methods for treating a patient, such as to treat pain. The patient can comprise a human or other mammalian patient. The medical apparatus can comprise a stimulation apparatus. The medical apparatus can comprise an implantable system and an external system. The implantable system can comprise one or more similar and/or dissimilar implantable devices. Each implantable device comprises a housing surrounding one or more stimulation producing components. A lead comprising one or more stimulation elements can be pre-attached to the housing, or attachable to the housing (e.g. attached in a clinical procedure in which the implantable device is implanted in a patient).

[79] The apparatus can include a trialing interface which provides energy to the stimulation elements during the implantation procedure, such as to confirm proper placement of the stimulation elements and/or to titrate the stimulation delivered. In embodiments in which the lead is pre-attached to the housing of the implantable device, the trialing interface can be configured to provide power (e.g. wireless power) to the implantable device, the implantable device providing stimulation energy to the stimulation elements derived from the power provided by the trialing interface. In embodiments in which the lead is attachable to the housing of the implantable device, the trialing interface can attach to the lead (prior to its attachment to the housing of the implantable device), and the trialing interface can then provide the stimulation energy directly to the stimulation elements.

[80] In some embodiments, the implantable system comprises a first implantable device that delivers stimulation energy via energy received wirelessly from one or more external devices, and a second implantable device that delivers stimulation energy via an integral (e.g. implanted) battery. In these embodiments, the first implantable device can be configured to deliver stimulation energy during a limited period of time (e.g. a trial period in which stimulation settings are determined and/or acceptability of the apparatus is determined), and the second implantable device can be configured to deliver stimulation energy for a prolonged period of time in which long-term stimulation therapy is provided to a patient. In these embodiments, a single implantable lead comprising one or more stimulation energy delivery elements (e.g.

electrodes) can be connected to the first implantable device and then the second implantable device. In some embodiments, a first implantable device can be configured to remain implanted in the patient for a limited period of time, such as to reduce cost of manufacture, and a second implantable device is configured for a longer implant life. The first implantable device can be used in a trialing procedure in which the stimulation apparatus is assessed for acceptable use (e.g. by the patient and/or clinician) and/or one or more stimulation settings are optimized or otherwise determined.

[81] Each implantable device can comprise one or more implantable antennas configured to receive power and/or data. Each implantable device can comprise an implantable receiver configured to receive the power and/or data from the one or more implantable antennas. Each implantable device can comprise one or more implantable functional elements (e.g. an implantable stimulation element). An implantable functional element can be configured to interface with the patient (e.g. interface with tissue of the patient or interface with any patient location). Alternatively or additionally, an implantable functional element can interface with a portion of an implantable device (e.g. to measure an implantable device parameter). In some embodiments, the one or more implantable functional elements can comprise one or more transducers, electrodes, and/or other elements configured to deliver energy to tissue. Alternatively or additionally, the one or more implantable functional elements can comprise one or more sensors, such as a sensor configured to record a physiologic parameter of the patient. In some embodiments, one or more implantable functional elements are configured to record device information and/or patient information (e.g. patient physiologic or patient environment information).

[82] Each implantable device can comprise an implantable controller configured to control (e.g. modulate power to, send a signal to, and/or receive a signal from) the one or more implantable functional elements. In some embodiments, an implantable controller of a first implantable device is configured to control one or more other implantable devices. Each implantable device can comprise an implantable energy storage assembly (e.g. a battery and/or a capacitor) configured to provide power to the implantable controller (e.g. a controller comprising a stimulation waveform generator), the implantable receiver and/or the one or more implantable functional elements. In some embodiments, an implantable energy storage assembly is further configured to provide power to an assembly that transmits signals via the implantable antenna (e.g. when the implantable device is further configured to transmit data to one or more external devices). Each implantable device can comprise an implantable housing surrounding the implantable controller and the implantable receiver. In some embodiments, one or more

implantable antennas are positioned within the implantable housing. Alternatively or additionally, one or more implantable antennas and/or implantable functional elements can be positioned outside the implantable housing, and tethered (e.g. electrically tethered) to one or more electrical components of the implantable device positioned within the implantable housing. In some embodiments, one or more implantable functional elements are positioned on an implantable lead, such as a flexible lead mechanically fixed or attachable to the implantable housing and operably connected (e.g. electrically, fluidly, optically and/or mechanically) to one or more components internal to the implantable housing. The implantable lead can be inserted (e.g. tunneled) through tissue of the patient, such that its one or more functional elements are positioned proximate tissue to be treated and/or positioned at an area in which data is to be recorded. In some embodiments, the implantable lead is configured to operably attach to and/or detach from, multiple implantable devices.

[83] The external system of the medical apparatus of the present inventive concepts can comprise one or more similar and/or dissimilar external devices. Each external device can comprise one or more external antennas configured to transmit power and/or data to one or more implanted components of the implantable system. Each external device can comprise an external transmitter configured to drive the one or more external antennas. Each external device can comprise an external power supply configured to provide power to at least the external transmitter. Each external device can comprise an external programmer configured to control the external transmitter and/or an implantable device (e.g. when an external power transmitter is not included in the apparatus or otherwise not present during use). Each external device can comprise an external housing that surrounds at least the external transmitter. In some embodiments, the external housing surrounds the one or more external antennas, the external power supply and/or the external programmer.

[84] The external programmer can comprise a discrete controller separate from the one or more external devices, and/or a controller integrated into one or more external devices. The external programmer can comprise a user interface, such as a user interface configured to set and/or modify one or more treatment and/or data recording settings of the medical apparatus of the present inventive concepts. In some embodiments, the external programmer is configured to collect and/or diagnose recorded patient information, such as to provide the information and/or diagnosis to a clinician of the patient, to a patient family member and/or to the patient themselves. The collected information and/or diagnosis can be used to adjust treatment or other operating parameters of the medical apparatus. In some embodiments, at least two external

programmers are included, such as a first external programmer configured for use by the patient, and a second external programmer configured for use by a clinician of the patient.

[85] In some embodiments, a medical apparatus comprises a stimulation apparatus for activating, blocking, affecting or otherwise stimulating (hereinafter “stimulate” or “stimulating”) tissue of a patient, such as nerve tissue or nerve root tissue (hereinafter “nerve”, “nerves”, “nerve tissue” or “nervous system tissue”). The stimulation apparatus comprises an external system configured to transmit power, and an implanted system configured to receive the power from the external system and to deliver stimulation energy to tissue. The delivered stimulation energy can comprise one or more stimulation waveforms, such as a stimulation waveform configured to enhance treatment of pain while minimizing undesired effects. The stimulation signal (also referred to as “stimulation energy” herein) delivered by the implanted system can be independent of the power received from the external system, such as to be independent of one or more of: the position of one or more components of the external system; the changing position of one or more components of the external system; the frequency of the power received from the external system; the amplitude of the power received from the external system; changes in amplitude of the power received from the external system; duty cycle of the power received from the external system; envelope of the power received from the external system; and combinations of one or more of these.

[86] Referring now to Fig. 1, a schematic anatomical view of a stimulation apparatus for providing a therapy to a patient is illustrated, consistent with the present inventive concepts.

Apparatus 10 comprises **implantable system 20** and **external system 50**. External system 50 transmits transmission signals to one or more components of implantable system 20. These transmission signals can comprise power and/or data. Implantable system 20 comprises **implantable device 200** shown implanted beneath the skin of patient P. In some embodiments, implantable system 20 comprises multiple similar or dissimilar implantable devices 200 (singly or collectively implantable device 200), such as is described in applicant’s co-pending United States Patent Application Serial Number 16/104,829, titled “Apparatus with Enhanced Stimulation Waveforms”, filed August 17, 2018 [Docket nos. 47476-708.301; NAL-014-US]. Each implantable device 200 can be configured to receive power and data from a transmission signal transmitted by external system 50, such as when stimulation energy delivered to the patient (e.g. to nerve or other tissue of the patient) by implantable device 200 is provided via wireless transmissions signals from external system 50. In some embodiments, implantable system 20 comprises at least two implantable devices, such as implantable device 200 and **implantable device 200’** shown in Fig. 1. Implantable device 200’ can be of similar

construction and arrangement to implantable device 200, and it can include components of a different configuration. Each implantable device 200 comprises one or more housings, **housing 210** shown, which surrounds various other components of device 200. Each implantable device 200 comprises one or more stimulation and/or other functional elements, such as **stimulation element 260** shown, where stimulation elements 260 are configured to deliver stimulation energy, a stimulating drug or other agent, and/or another form of stimulation (e.g. another form of tissue stimulation) to the patient. In some embodiments, one or more stimulation elements 260 are further configured as a sensor (e.g. when comprising an electrode configured to both deliver electrical energy and record electrical signals). Each implantable device 200 can include one or more leads, **lead 265** shown, and each lead 265 can include one or more stimulation elements 260. Alternatively or additionally, one or more stimulation elements 260 can be positioned on housing 210 or one or more other components of implantable device 200.

[87] Each implantable device 200 can comprise one or more other types of functional elements, such as **functional element 299a** shown positioned proximate housing 210 (e.g. within and/or on the external surface of housing 210) and/or **functional element 299b** shown positioned on lead 265. Functional element 299a and/or 299b (singly or collectively **functional element 299**) can comprise a transducer, a sensor, and/or other functional element as described herein. In some embodiments, a functional element 299 comprises a visualizable marker, such as a radiopaque marker, an ultrasonically visible marker, and/or a magnetic marker.

[88] External system 50 can comprise an **external device 500**, which includes one or more housings, **housing 510** shown, which surrounds various other components of device 500. In some embodiments, external system 50 comprises multiple external devices 500 (singly or collectively external device 500), such as an external device as is described in applicant's co-pending United States Patent Application Serial Number 16/104,829, titled "Apparatus with Enhanced Stimulation Waveforms", filed August 17, 2018 [Docket nos. 47476-708.301; NAL-014-US]. In some embodiments, external system 50 comprises at least two, or at least three external devices (e.g. at least two external devices configured to deliver power and/or data to one or more implantable devices 200), such as external device 500, **external device 500'**, and **external device 500''** shown in Fig. 1. External device 500' and/or 500'' can be of similar construction and arrangement to external device 500, and these devices can include components of a different configuration.

[89] External system 50 can comprise one or more programming devices, **programmer 600**, such as **patient programmer 600'** and **clinician programmer 600''** shown. Patient programmer 600' and clinician programmer 600'' (singly or collectively programmer 600) each

comprise a user interface, such as **user interfaces 680' and 680''** shown (singly or collectively user interface 680). Programmer 600 can be configured to control one or more external devices 500. Alternatively or additionally, programmer 600 can be configured to control one or more implantable devices 200 (e.g. when no external device 500 is included in apparatus 10 or at least no external device 500 is available to communicate with an implantable device 200). Patient programmer 600' can be configured to be used by the patient, patient caregiver (e.g. clinician of the patient), and/or a family member of the patient.

[90] Clinician programmer 600'' can be of similar construction and arrangement to patient programmer 600'. In some embodiments, clinician programmer 600'' provides additional functions not available in patient programmer 600'. In some embodiments, clinician programmer 600'' can modify the programming of patient programmer 600' (e.g. modify the programming options available to the patient or family member of the patient).

[91] Patient programmer 600' can be further configured as a smart phone and/or a music playing device (e.g. an mp3 player). For example, patient programmer 600' can comprise a smart phone or other commercial device onto which a software program of apparatus 10 is embedded to cause the commercial device to function as patient programmer 600'. Clinician programmer 600'' can comprise a tablet-like device. For example, clinician programmer 600'' can comprise a commercial tablet device onto which a software program of apparatus 10 is embedded to cause the commercial tablet to function as clinician programmer 600''.

[92] Clinician programmer 600'' can configure multiple (e.g. all) external devices 500 used by a patient, as well as patient programmer 600', so that the set of devices are configured as a "trusted" network. After this configuration, patient programmer 600' can safely and effectively communicate with the one or more external devices 500 of the patient. The patient programmer 600' can upload (e.g. automatically upload) configuration information from an external device 500 (e.g. stimulation settings and the like). In some embodiments, patient programmer 600' and/or clinician programmer 600'' uploads configuration information from an external device 500 any time certain information (e.g. stimulation information) on that external device 500 has changed (e.g. a change is detected by the programmer 600 or otherwise).

[93] External system 50 can comprise one, two, three, or more functional elements, such as functional elements **599a, 599b, and/or 599c** (singly or collectively functional element 599), shown positioned in external device 500, patient programmer 600', and clinician programmer 600'', respectively.

[94] Apparatus 10 can be configured to stimulate tissue (e.g. stimulate nerve tissue such as tissue of the central nervous system or tissue of the peripheral nervous system, such as to

neuromodulate nerve tissue), such as by having one or more implantable devices 200 deliver and/or otherwise provide energy (hereinafter “deliver energy”) and/or deliver an agent (e.g. a pharmaceutical compound or other agent) to one or more tissue locations, such as via one or more stimulation elements 260. In some embodiments, one or more implantable devices 200 deliver energy and/or an agent while receiving power and/or data from one or more external devices 500. In some embodiments, one or more implantable devices 200 deliver energy and/or an agent (e.g. continuously or intermittently) using energy provided by an internal power source (e.g. a battery and/or capacitor) without receiving externally supplied power, such as for periods of at least 1 hour, at least 1 day, at least 1 month or at least 1 year. In some embodiments, one or more stimulation parameters are varied (e.g. systematically and/or randomly), during that period.

[95] In some embodiments, apparatus 10 is further configured as a patient diagnostic apparatus, such as by having one or more implantable devices 200 record a patient parameter (e.g. a patient physiologic parameter) from one or more tissue locations, such as while receiving power and/or data from one or more external devices 500. In some embodiments, during its use, one or more implantable devices 200 at least receives power from one or more external devices 500 (e.g. with or without also receiving data). Alternatively or additionally, one or more patient parameters can be recorded by an external device of apparatus 10, such as via a programmer 600 and/or an external device 500.

[96] Apparatus 10 can be configured as a patient information recording apparatus, such as by having one or more implantable devices 200 and/or one or more external devices 500 record patient information (e.g. patient physiologic information and/or patient environment information). In some embodiments, one or more implantable devices 200 and/or one or more external devices 500 further collect information (e.g. status information or configuration settings) of one or more of the components of apparatus 10.

[97] In some embodiments, apparatus 10 is configured to deliver stimulation energy to tissue to treat pain. In particular, apparatus 10 can be configured to deliver stimulation energy to tissue of the spinal cord and/or tissue associated with the spinal cord (“tissue of the spinal cord”, “spinal cord tissue” or “spinal cord” herein), the tissue including roots, dorsal root, dorsal root ganglia, spinal nerves, ganglia, and/or other nerve tissue. The delivered energy can comprise energy selected from the group consisting of: electrical energy; magnetic energy; electromagnetic energy; light energy such as infrared light energy, visible light energy and/or ultraviolet light energy; mechanical energy; thermal energy such as heat energy and/or cryogenic energy; sound energy such as ultrasonic sound energy (e.g. high intensity focused ultrasound and/or low intensity focused ultrasound) and/or subsonic sound energy; chemical energy; and

combinations of one or more of these. In some embodiments, apparatus 10 is configured to deliver to tissue energy in a form selected from the group consisting of: electrical energy such as by providing a controlled (e.g. constant or otherwise controlled) electrical current and/or voltage to tissue; magnetic energy (e.g. magnetic field energy) such as by applying controlled current or voltage to a coil or other magnetic field generating element positioned proximate tissue; and/or electromagnetic energy such as by providing both current to tissue and a magnetic field to tissue. A coil or other magnetic field generating element can surround (e.g. at least partially surround) the target nerve. Alternatively, or additionally, the magnetic energy can be applied externally and focused to specific target tissue via an implant comprising a coil and/or ferromagnetic materials. In some embodiments, the magnetic energy is configured to induce the application of mechanical energy. Delivered energy can be supplied in one or more stimulation waveforms, each waveform comprising one or more pulses of energy, as described in detail herebelow.

[98] In some embodiments, apparatus 10 is configured as a stimulation apparatus in which external system 50 transmits a power signal to one or more implantable devices 200, and the one or more implantable devices 200 deliver stimulation energy to tissue with a stimulation signal (also referred to as a stimulation waveform), with the power signal and the stimulation signal having one or more different characteristics (e.g. as described herebelow). The power signal can be modulated with data (e.g. configuration or other data to be sent to one or more implantable devices 200). In these embodiments, the characteristics of the stimulation signal delivered (e.g. amplitude, frequency, duty cycle and/or pulse width), can be independent (e.g. partially or completely independent) of the characteristics of the power signal transmission (e.g. amplitude, frequency, phase, envelope, duty cycle and/or modulation). For example, the frequency and modulation of the power signal can change without affecting those or other parameters of the stimulation signal, and/or the parameters of the stimulation signal can be changed (e.g. via programmer 600), without requiring similar or any changes to the power signal. In some embodiments, implantable system 20 is configured to rectify the received power signal, and to produce a stimulation waveform with entirely different characteristics (e.g. amplitude, frequency and/or duty cycle) from the rectified power signal. Each implantable device 200 can comprise an oscillator and/or controller configured to produce the stimulation signal. In some embodiments, one or more implantable devices 200 is configured to perform frequency multiplication, in which multiple signals are multiplexed, mixed, added, and/or combined in other ways to produce a broadband stimulation signal.

[99] In some embodiments, apparatus 10 is configured such that external system 50 transmits data (e.g. data and power) to implantable system 20, and implantable system 20

recovers (e.g. decodes, demodulates or otherwise recovers) the transmitted data without synchronizing to the carrier and/or data symbol rate of the transmitted signal from external system 50. In some embodiments, the transmitted signal comprises a power signal, and a clock and/or data is recovered without synchronizing to the power signal. In some embodiments, the transmitted signal comprises a clock and/or data signal, and a clock and/or data is recovered without synchronizing to the transmitted clock and/or data signal. In some embodiments, the recovered signal comprises a clock and/or data and a clock and/or data is recovered from the transmission signal without synchronizing to the recovered clock and/or data. Avoiding synchronization reduces power consumption of each implantable device 200, such as by obviating the need for (and avoiding the power consumed by) a frequency locked loop (FLL); phase locked loop (PLL); high frequency clock; and/or crystal oscillator needed to perform the synchronization. Avoiding these components can also be correlated to reduced package size of each implantable device 200 (e.g. avoidance of a relatively large sized crystal oscillator). Asynchronous data transfer between external system 50 and implantable system 20 is also advantageous as it relates to: increased communication data rate; power transfer efficiency; operation with more than one implantable device 200; and combinations of one or more of these. In some embodiments, one or more components of apparatus 10 are of similar construction and arrangement as similar components described in United States Patent Application Serial Number 13/591,188, titled “Method of Making and Using an Apparatus for a Locomotive Micro-Implant using Active Electromagnetic Propulsion”, filed August 21, 2012. In some embodiments, external system 50 and implantable system 20 provide asynchronous data transfer or are otherwise configured as described in United States Patent Application Serial Number 13/734,772, titled “Method and Apparatus for Efficient Communication with Implantable Devices”, filed January 4, 2013.

[100] Apparatus 10 can be configured to treat pain, such as back pain and/or limb pain treated by stimulating dorsal root ganglia and/or other nerves or locations of the spinal cord or other nervous system locations. In some embodiments, apparatus 10 is configured to treat a type of pain selected from the group consisting of: back pain; joint pain; neuropathic pain; tennis elbow; muscle pain; shoulder pain; chronic, intractable pain of the back and/or limbs including unilateral or bilateral pain; neuropathic groin pain; perineal pain; phantom limb pain; complex regional pain syndrome; failed back surgery syndrome; cluster headaches; migraines; inflammatory pain; arthritis; abdominal pain; pelvic pain; and combinations of one or more of these.

[101] In some embodiments, apparatus 10 is configured to treat a patient disease or disorder selected from the group consisting of: chronic pain; acute pain; migraine; cluster headaches; urge incontinence; pelvic dysfunction such as overactive bladder; fecal incontinence; bowel disorders; tremor; obsessive compulsive disorder; depression; epilepsy; inflammation; tinnitus; hypertension; heart failure; carpal tunnel syndrome; sleep apnea; obstructive sleep apnea; dystonia; interstitial cystitis; gastroparesis; obesity; mobility issues; arrhythmia; rheumatoid arthritis; dementia; Alzheimer's disease; eating disorder; addiction; traumatic brain injury; chronic angina; congestive heart failure; muscle atrophy; inadequate bone growth; post-laminectomy pain; liver disease; Crohn's disease; irritable bowel syndrome; erectile dysfunction; kidney disease; and combinations of one or more of these.

[102] In some embodiments, apparatus 10 is configured to treat one or more diseases or disorders by delivering stimulation to perform renal modulation. In some embodiments, apparatus 10 is configured to treat hypertension, such as when apparatus 10 is configured to deliver stimulation to perform renal neuromodulation.

[103] Apparatus 10 can be configured to treat heart disease, such as heart failure of a patient. In these embodiments, stimulation of the spinal cord can be performed. In canine and porcine animals with failing hearts, spinal cord stimulation has been shown to reverse left ventricular dilation and improve cardiac function, while suppressing the prevalence of cardiac arrhythmias. In canines, coronary artery occlusion has been associated with increased intracardiac nerve firing, and stimulation at spinal segment T1 has been shown to suppress that nerve firing. Stimulation via apparatus 10 at one or more spinal cord locations can be used to suppress undesired cardiac nerve firing in humans and other mammalian patients. In some embodiments, stimulation via apparatus 10 at multiple spinal cord locations is used to enhance a cardiac treatment. For example, one or more stimulation elements 260 of one or more implantable devices 200 can be implanted at one or more spinal cord locations, such as to deliver stimulation to tissue proximate those locations. In some embodiments, stimulation elements 260 comprise two or more stimulation elements (e.g. electrodes) that span multiple vertebra of the spinal column (e.g. multiple stimulation elements that span at least T8 to T9 and/or T-9 to T-10). Power and/or data can be transmitted to the one or more implantable devices 200 via one or more external devices 500 of external system 50. One or more stimulation signals can be delivered to spinal cord tissue, such as to treat heart failure or other cardiac disease or disorder. In some embodiments, one or more stimulation elements 260 are configured to deliver energy (e.g. electrical energy) to tissue to treat heart failure, such as tissue selected from the group consisting of: spinal canal; nerves in the spinal canal; nerves in the epidural space; peripheral nerves;

posterior spinal nerve root; dorsal root; dorsal root ganglion; pre-ganglionic tissue on posterior spinal nerve root; post-ganglionic tissue on posterior nerve root; dorsal ramus; grey ramus communicans; white ramus communicans; ventral ramus; and combinations of one or more of these. In some embodiments, one or more functional elements of apparatus 10 (e.g. one or more stimulation elements 260, functional elements 299, functional elements 599 and/or other functional elements of implantable system 20) are configured (e.g. further configured) to record a patient parameter (e.g. stimulation element 260, functional element 299, functional element 599, and/or another functional element of apparatus 10 are configured as a sensor), such as a patient heart or spine parameter, and the information recorded is used to adjust the delivered stimulation signals. The at least one heart parameter can comprise a parameter selected from the group consisting of: EKG; blood oxygen; blood pressure; heart rate; ejection fraction; wedge pressure; cardiac output; and combinations of one or more of these.

[104] Apparatus 10 can be configured to pace and/or defibrillate the heart of a patient. One or more stimulation elements 260 can be positioned proximate cardiac tissue and deliver a stimulation signal as described herein (e.g. based on power and/or data received by implantable system 20 from external system 50). The stimulation signal can be used to pace, defibrillate and/or otherwise stimulate the heart. Alternatively or additionally, apparatus 10 can be configured to record cardiac activity (e.g. by recording EKG, blood oxygen, blood pressure, heart rate, ejection fraction, wedge pressure, cardiac output, lung impedance and/or other properties or functions of the cardiovascular system via a sensor-based element 260, and/or other sensor of apparatus 10), such as to determine an onset of cardiac activity dysfunction or other undesired cardiac state. In some embodiments, apparatus 10 is configured to both record cardiac or other information and deliver a stimulation signal to cardiac tissue (e.g. stimulation varied or otherwise based on the recorded information). For example, apparatus 10 can be configured such that external system 50 transmits power and/or data to implantable system 20. Implantable system 20 monitors cardiac activity, and upon detection of an undesired cardiovascular state, implantable system 20 delivers a pacing and/or defibrillation signal to the tissue that is adjacent to one or more stimulation elements 260 configured to deliver a cardiac stimulation signal.

[105] Apparatus 10 can be configured to perform a diagnostic procedure including measuring one or more patient parameters (e.g. patient physiologic or other patient parameters), such as are described in detail herebelow. In some embodiments, apparatus 10 is configured to measure a physiologic parameter that can be sensed from one or more sensor-based stimulation elements 260, functional elements 299, and/or functional elements 599 positioned in

subcutaneous tissue. In these embodiments, external system 50 can comprise an external device 500 configured for placement proximate an implantable device 200 implanted in a position to record data from subcutaneous tissue (e.g. blood glucose data). External device 500 can comprise a wrist band, a wristwatch, and/or an arm band configuration such as when the implantable device 200 is positioned in subcutaneous tissue proximate the patient's wrist or upper arm. The external device 500 can comprise a leg, knee or ankle band configuration, such as when one or more implantable devices 200 are positioned in subcutaneous tissue proximate the patient's ankle, knee, and/or thigh. In some embodiments, external device 500 comprises a band or other attachment device for positioning about the thorax, neck, groin, and/or head of the patient. Power and/or data can be sent to the implantable device 200 from the external device 500, and data (e.g. blood glucose data) can be sent to external device 500 (or another component of external system 50) by implantable device 200, such as using a wireless communication configuration known to those of skill in the art. In some embodiments, external system 50 comprises a functional element 599 (e.g. functional element 599a, 599b, and/or 599c) configured to deliver an agent (e.g. insulin or glucose delivered by a needle-based functional element 599), based on the information received from implantable device 200. Alternatively, or additionally, implantable device 200 comprises a stimulation element 260 configured to deliver an agent (e.g. insulin or glucose delivered by a needle-based stimulation element 260), based on the information recorded by implantable device 200. Various closed loop sensing and agent delivery combinations and configurations should be considered within the spirit and scope of the present inventive concepts, including but not limited to: sensing a blood parameter such as white blood cell count and delivering a chemotherapeutic or other agent based on the blood parameter; sensing a hormone level and delivering a hormone or a hormone affecting agent; sensing blood pressure and delivering stimulation energy and/or a blood pressure affecting agent; sensing neural activity and delivering stimulation energy and/or a neural affecting agent or other agent based on the neural activity, such as for treating epilepsy; and combinations of one or more of these.

[106] As described hereabove, external system 50 can be configured to transmit power and/or data (e.g. implantable system 20 configuration data) to one or more implantable devices 200 of implantable system 20. Implantable system 20 configuration data provided by external system 50 (e.g. via one or more antennas, **antenna 540** shown, of one or more external devices 500) can include when to initiate stimulation delivery (e.g. energy delivery), and/or when to stop stimulation delivery, and/or it can include data related to the value or change to a value of one or more stimulation variables as described hereabove. The configuration data can include a

stimulation parameter such as an agent (e.g. a pharmaceutical agent) delivery stimulation parameter selected from the group consisting of: initiation of agent delivery; cessation of agent delivery; amount of agent to be delivered; volume of agent to be delivered; rate of agent delivery; duration of agent delivery; time of agent delivery initiation; and combinations of one or more of these. The configuration data can include a sensing parameter, such as a sensing parameter selected from the group consisting of: initiation of sensor recording; cessation of sensor recording; frequency of sensor recording; resolution of sensor recording; thresholds of sensor recording; sampling frequency of sensor recording; dynamic range of sensor recording; initiation of calibration of sensor recording; and combinations of one or more of these.

[107] As described hereabove, external system 50 can comprise one or more external devices 500. External system 50 can comprise one or more antennas 540, such as when a single external device 500 comprises one or more antennas 540, and/or when multiple external devices 500 each comprise one or more antennas 540. The one or more antennas 540 can transmit power and/or data to one or more **antennas 240** of implantable system 20, such as when a single implantable device 200 comprises one or more antennas 240, and/or when multiple implantable devices 200 each comprise one or more antennas 240. In some embodiments, one or more antennas 540 define a radiation footprint (e.g. a footprint defining a volume, such as a volume of tissue, in which electromagnetic transmissions radiated by antennas 540 can be properly received by antennas 240), such as is described in applicant's co-pending United States Patent Application Serial Number 15/664,231, titled "Medical Apparatus Including an Implantable System and an External System ", filed July 31, 2017 [Docket nos. 47476-706.301; NAL-011-US].

[108] External system 50 transmits power and/or data with a transmission signal comprising at least one wavelength, λ . External system 50 and/or implantable system 20 can be configured such that the distance between an external antenna 540 transmitting the power and/or data and one or more implantable antennas 240 receiving the power and/or data transmission signal is equal to between 0.1λ and 10.0λ , such as between 0.2λ and 2.0λ . In some embodiments, one or more transmission signals are delivered by a transmitter, **transmitter 530**, at a frequency range between 10MHz and 10.6GHz, such as between 0.1GHz and 10.6GHz, between 10MHz and 3.0GHz, between 40MHz and 1.5GHz, between 10MHz and 100MHz, between 0.902GHz and 0.928GHz, in a frequency range proximate to 40.68MHz, in a frequency range proximate to 866MHz, or approximately between 863MHz and 870MHz. Transmitter 530 can comprise a transmitter that produces a transmission signal with a power level between 0.01W and 4.0W, such as a transmission signal with a power level between 0.01W and 2.0W or between 0.2W and 1.0W.

[109] In addition to transmitting power and/or data to implantable system 20, external system 50 can be further configured to provide information (e.g. patient information and/or apparatus 10 performance information) to one or more other components of apparatus 10, such as **tool 60** shown in Fig. 1 and described in detail herebelow.

[110] One or more external devices 500 (singly or collectively external device 500) can be configured to transmit power and/or data (e.g. implantable system 20 configuration data) to one or more implantable devices 200 (singly or collectively implantable device 200). In some embodiments, one or more external devices 500 are configured to transmit both power and data (e.g. simultaneously and/or sequentially) to one or more implantable devices 200. In some embodiments, one or more external devices 500 are further configured to receive data from one or more implantable devices 200 (e.g. via data transmitted by one or more antennas 240 of one or more implantable devices 200). Each external device 500 can comprise housing 510, **power supply 570**, a transmitter 530, a **controller 550**, and/or one or more antennas 540, each shown in Fig. 1 and described in detail herebelow. Each external device 500 can further comprise one or more functional elements 599a, such as a functional element comprising a sensor, electrode, energy delivery element, a magnetic-field-generating transducer, and/or any transducer, also described in detail herebelow. In some embodiments, a functional element 599a comprises one or more sensors configured to monitor performance of external device 500 (e.g. to monitor voltage of power supply 570, quality of transmission of power and/or data to implantable system 20, temperature of a portion of an external device 500, and the like).

[111] One or more housings 510 (singly or collectively housing 510) of each external device 500 can comprise one or more rigid and/or flexible materials which surround various components of external device 500 such as antenna 540, transmitter 530, controller 550, and/or power supply 570 shown in Fig. 1. In some embodiments, a single external device 500 comprises multiple discrete (i.e. separate) housings 510, two or more of which can each transfer data and/or other signals via a wired or wireless connection to the other, to an implantable device 200, and/or to another component of apparatus 10. In some embodiments, a housing 510 further surrounds a programmer 600 (e.g. programmer 600' or 600'') and/or a power supply 570. In some embodiments, housing 510 comprises both a rigid material and a flexible material. In some embodiments, housing 510 comprises a material selected from the group consisting of: plastic; injection-molded plastic; an elastomer; metal; and combinations of one or more of these. In some embodiments, housing 510 comprises a shielded portion (e.g. shielded to prevent transmission of electromagnetic waves), and an unshielded portion, such as an unshielded portion surrounding antenna 540.

[112] Housing 510 can comprise an adhesive element (e.g. a spacer 511 configured as an adhesive element), such as an adhesive element configured to temporarily attach an external device 500 to the patient's skin. Alternatively or additionally, housing 510 can be constructed and arranged to engage (e.g. fit in the pocket of) a patient attachment device, such as **patient attachment device 70** described herebelow.

[113] One or more antennas 540 (singly or collectively antenna 540) can each comprise one, two, three, or more external antennas. Antenna 540 can comprise one or more polarizable antennas, such as one or more antennas with adjustable polarization. Antenna 540 can comprise an array of antennas, such as an array of antennas configured to: support beam shaping and/or focusing; allow adjustment of the amplitude and/or phase of the transmission signal; increase the radiation footprint; and combinations of one or more of these. An array of antennas 540 can be configured to be selectively activated, such as to improve coupling with one or more implanted antennas 240, such as to adjust for movement of the array of the antennas 540 relative to the implanted antennas 240. Antenna 540 can comprise an array of selectable conductors configured to adjust a radiation pattern and/or an electromagnetic field of a resultant antenna. Antenna 540 can comprise a surface and shield material positioned on the surface, such as when the shield material is positioned on the side facing away from the patient's skin. The shield material can comprise radio-absorptive shield material and/or radio-reflective shield material. For antenna 540 to operate effectively at higher frequencies, the shield material can comprise a ferrite material that has a low conductivity and low magnetic loss tangent at a frequency of interest, and whereby a higher permeability is achieved. By placing a material with a high magnetic permeability (μ'), low magnetic loss tangent (μ''/μ'), and low conductivity at the operating frequency (such as a high frequency ferrite) between the antenna and other elements of the transmitter, the losses or loading effects due to these elements can be dramatically reduced. In some cases, the magnetic field magnification of this shielding layer will enhance the overall performance. Additionally, this layer shields the outside environment from unwanted radiation from the antenna, and it protects the antenna from radiation originating in the environment.

[114] In some embodiments, a spacing layer is positioned between antenna 540 and the shield material. The spacing layer can comprise a thickness of between 0mm and 5mm, such as between 0.25mm and 1mm. The spacing layer can comprise non-conductive dielectric materials, air, or other materials that have minimal impact on antenna performance. The spacing layer can also be incorporated into a board thickness, with the antenna being constructed on the opposite side of the board in relation to the shielding layer. The shielding layer can comprise a ferrite material as described hereabove, or any material with the desired permeability, magnetic

loss, and conductivity at the frequency of interest. The thickness of the shielding layer can be dependent on its specific material properties and the application. In some embodiments, a conductive layer on the side of the shielding layer is positioned opposite the antenna to further shield unwanted radiation. To reduce weight, the shielding layer material can be porous or incorporate holes or slots spaced in a way to minimize the reduction in performance. The holes and spacings can be sized smaller than a wavelength of the RF signal. If no spacing layer is used, the shielding layer can extend inside the antenna. Additionally or alternatively, the shielding layer can be positioned on the other side or both sides of the antenna because of the field magnification effect. In some embodiments, the shielding layer is constructed to increase the directivity of the antenna or focus the electromagnetic energy.

[115] One or more antennas 540 can be positioned in a housing 510 that is otherwise void of other components (e.g. void of power supply 570, controller 550 and/or transmitter 530), such as when an antenna 540 is positioned within a first housing 510 and communicates with components positioned in a second housing 510.

[116] In some embodiments, one or more spacers, **spacer 511** shown, is positioned between antenna 540 and the patient's skin, such as a spacer comprising a thickened portion of housing 510 or a discrete spacer 511 placed on a side of housing 510 (as shown) or on a side of antenna 540. Spacer 511 can comprise one or more materials that match the impedance of antenna 540 to the impedance of the patient's tissue. Spacer 511 can comprise a thickness of between 0.1cm to 3cm, such as a thickness between 0.2cm and 1.5cm. Spacer 511 can comprise materials which isolate heat (e.g. a spacer 511 comprising thermally insulating material). Alternatively, or additionally, housing 510 can comprise a heat insulating and/or dissipating material. Spacer 511 can comprise a soft or otherwise compressible material (e.g. foam) for patient comfort. Spacer 511 can be inflatable, such as to control the separation distance of an external antenna 540 from the patient's skin. An inflatable spacer 511 can be compartmentalized into several sections with independently controlled air pressure or volume to adjust the separation distance of an external antenna 540 and the patient's skin and/or its angle (e.g. tilt) with respect to the tissue surface.

[117] In some embodiments, antenna 540 comprises a multi-feed point antenna, such as a multi-feed point antenna configured to: support beam shaping and/or focusing; allow adjustment of amplitude and/or phase of a transmission signal; increase the radiation footprint; or combinations of one or more of these.

[118] In some embodiments, antenna 540 comprises one or more antennas selected from the group consisting of: patch antenna; slot antenna; array of antennas; a loop antenna (e.g. a

concentric loop antenna); antenna loaded with reactive elements; dipole antenna; polarizable antenna; selectable conductors that form an antenna; and combinations of one or more of these.

[119] Antenna 540 can comprise a major axis between 1cm and 10cm, such as a major axis between 2cm and 5cm, and/or a major axis of approximately 4cm. Antenna 540 can be further configured to receive a signal, such as when an antenna 240 is configured to transmit data to an external device 500. Antenna 540 can be positioned on (e.g. fabricated onto) a substrate, such as a flexible printed circuit board or other printed circuit board (e.g. a single or multiple layer printed circuit board comprising electrical traces connecting components).

[120] A single external antenna 540 can be configured to transmit power and/or data to multiple implantable devices 200 (e.g. each containing one or more antennas 240). In some embodiments, a single external device 500, comprising one or more antennas 540 can be configured to transmit power and/or data to multiple implantable devices 200.

[121] One or more antennas 540 can comprise a multi-turn spiral loop antenna, such as a multi-turn spiral loop antenna configured to desensitize coupling sensitivity and/or boost input voltage. In some embodiments, one or more antennas 540 comprise multiple concentric loops with varied dimensions, such as concentric loops configured to desensitize coupling sensitivity. In these embodiments, the multiple concentric loops can be: connected in parallel and driven from the same feed point; driven from the same feed point and connected using one or more of a capacitor, inductor, varactor, and combinations of one or more of these; and/or driven from multiple feed points.

[122] In some embodiments, one or more external devices 500 comprise a first antenna 540 and a second antenna 540. In these embodiments, the first antenna 540 can be similar or dissimilar to the second antenna 540. In some embodiments, a first antenna 540 and a dissimilar second antenna 540 are positioned within a single external device 500 (e.g. within housing 510). In other embodiments, a first antenna 540 is positioned in a first external device 500, and a dissimilar second antenna 540 is positioned in a second external device 500. The similarity or dissimilarity of the antennas can be configured to enhance one or more design and/or performance parameters selected from the group consisting of: implantable device 200 operation depth; polarization; power efficiency; a radiation footprint; directional gain; beam shaping and/or focusing; sensitivity to implantable device 200 placement; patient comfort; patient usability; data transfer; and combinations of one or more of these. In some embodiments, the first antenna 540 is optimized for a different design parameter than the second antenna 540, and each antenna 540 can be activated independently or simultaneously to realize both benefits. In some embodiments, the first antenna 540 is similar to the second antenna 540 and placed in an array to increase the

radiation footprint or placed in different external locations to operate with multiple implantable devices 200 implanted at different sites.

[123] In some embodiments, a first external antenna 540 and a second external antenna 540 transmit power and/or data to a single implantable antenna 240. In some embodiments, a first antenna 540 and a second antenna 540 transmit power and/or data to one or more antennas 240, the transmissions performed simultaneously or sequentially. In sequential power and/or data transfers, a first external device 500 comprising a first one or more antennas 540 can be replaced (e.g. swapped) with a second external device 500 comprising a second one or more antennas 540. Alternatively or additionally, sequential power and/or data transfer can be initiated by one or more of the following conditions: when a first external antenna 540 moves (e.g. moves relative to an implanted antenna 240); when a second external device 500 comprising a second antenna 540 is turned on or otherwise activated; when a second antenna 540 provides improved power and/or data transfer to antenna 240 than that which is provided by a first antenna 540; and/or when power received from a first antenna 540 decreases (e.g. decreases below a threshold). In some embodiments, an antenna 240 receives power from a first antenna 540 and a second antenna 540, but only receives data from the first antenna 540. In some embodiments, a first antenna (e.g. an antenna 240 or an antenna 540) is driven with a different carrier signal than a second antenna (e.g. an antenna 240 or an antenna 540). The two carrier signals can comprise differences in amplitudes and/or relative phases as compared to each other. Each carrier signal can include a data transmission signal (e.g. data to be transmitted to an implantable device 200 from an external device 500 or to an external device 500 from an implantable device 200).

[124] External device 500 can comprise an electronics module, controller 550 shown, configured to control one or more other components of external device 500.

[125] One or more transmitters 530 (singly or collectively external transmitter 530) can each comprise one or more external transmitters that drive one or more antennas 540 (e.g. one or more antennas 540 positioned in a single external device 500 or multiple external devices 500). Transmitter 530 is operably attached to antenna 540 and is configured to provide one or more drive signals to antenna 540, such as one or more power signals and/or data signals transmitted to one or more implantable devices 200 of implantable system 20. Transmitter 530 can be configured to perform multi-level amplitude shift keying. The amplitude shift-keying can be configured to provide adjustable-depth modulation between 0-100% depth, such as between 5-75% depth, or such as between 10-50% depth.

[126] As described herein, one or more external devices 500 can be configured to transmit data (e.g. configuration data) to one or more implantable devices 200, such as via a data

transmission produced by transmitter 530 and sent to one or more antennas 540. In some embodiments, a transmitter 530 is configured to perform data modulation comprising amplitude shift keying with pulse width modulation. In these embodiments, the transmitter can be configured to perform multi-level amplitude shift keying. The amplitude shift-keying can be configured to provide adjustable-depth modulation between 0-100% depth, such as between 5-75% depth, or such as between 10-50% depth. In some embodiments, one or more external devices 500 transmit data to one or more implantable devices 200 using time division multiple access (TDMA). In some embodiments, one or more implantable devices 200 are independently addressable through unique identification (ID) codes. Alternatively or additionally, transmitter 530 can be configured to transmit one or more data signals with a bandwidth between 1kHz and 100MHz, between 0.1MHz and 100MHz, or between 1MHz and 26MHz.

[127] As described herein, one or more external devices 500 can be configured to transmit power to one or more implantable devices 200, such as via a power transmission produced by transmitter 530 and set to one or more antennas 540. One or more transmitters 530 can deliver power to one or more implantable devices 200 simultaneously or sequentially. In some embodiments, one or more transmitters 530 are configured to adjust the level of power transmitted to one or more implantable devices 200, such as by adjusting one or more duty cycling parameters. In these embodiments, power transmitted can be adjusted to: set a power transfer based on a stimulation level produced by implantable system 20; prevent oversaturation; to reduce interference with implantable system 20 data transmissions (e.g. when one or more implantable devices 200 are further configured to transmit data to external system 50); set a power transfer based on charge information and/or discharge information related to an implantable device 200 (e.g. charge rate and/or discharge rate of implantable **energy storage assembly 270** described herebelow); and combinations of one or more of these. In some embodiments, implantable system 20 comprises a first **receiver 230** (e.g. of a first implantable device 200) and a second receiver 230 (e.g. of a second implantable device 200'). One or more transmitters 530 can be configured to transmit a first power transmission to the first receiver 230, and a second power transmission to the second receiver 230. The first power transmission and the second power transmission can be adjusted or otherwise be different, such as to prevent oversaturation.

[128] In some embodiments, transmitter 530 (and/or another component of external system 50) is further configured as a receiver (e.g. can further include a receiver, in addition to a transmitter or include a transmitter that further functions as a receiver), such as to receive data from implantable system 20. For example, a transmitter 530 can be configured to receive data

via one or more antennas 240 of one or more implantable devices 200. Data received can include patient information (e.g. patient physiologic information, patient environment information or other patient information) and/or information related to an implantable system 20 parameter (e.g. an implantable device 200 stimulation parameter and/or other configuration parameter as described herein).

[129] In some embodiments, transmitter 530 comprises a first transmitter to transmit power and/or data to one or more implantable devices 200, and a second transmitter to transmit data to a different device, as described herein. In these embodiments, a second transmitter of transmitter 530 can be configured to transmit data to tool 60 or another device such as a programmer 600; cell phone; computer; tablet; computer network such as the internet or a LAN; and combinations of one or more of these. In some embodiments, the second transmitter of transmitter 530 comprises a wireless transmitter; a Bluetooth transmitter; a cellular transmitter; and combinations of one or more of these. In some embodiments, a functional element 599 comprises a transmitter such as a Bluetooth transmitter.

[130] Each power supply 570 (singly or collectively power supply 570) can be operably attached to a transmitter 530, and one or more other electrical components of each external device 500. Power supply 570 can comprise a power supplying and/or energy storage element selected from the group consisting of: battery; replaceable battery (e.g. via a battery door of housing 510); rechargeable battery; AC power converter; capacitor; and combinations of one or more of these. In some embodiments, power supply 570 comprises two or more batteries, such as two or more rechargeable batteries, such as to allow the first battery to be replaced (e.g. serially replaced) by the second battery (e.g. external device 500 can function with a single battery). In some embodiments, power supply 570 is configured to provide a voltage of at least 3V. In some embodiments, power supply 570 is configured to provide a capacity between 1Watt-hour and 75Watt-hours, such as a battery or capacitor with a capacity of approximately 5Watt-hours. In some embodiments, power supply 570 comprises an AC power source. Power supply 570 can include voltage and/or current control circuitry. Alternatively or additionally, power supply 570 can include charging circuitry, such as circuitry configured to interface a rechargeable battery with an external charging device. In some embodiments, apparatus 10 includes one or more charging devices, **charger 61 shown**, which can be configured to recharge a component of apparatus 10, such as to recharge power supply 570 of one or more external devices 500, such as is described herebelow in reference to Figs. 17A-D.

[131] Each external device 500 can include one or more user interface components, **user interface 580 shown**, such as to allow the patient or other user to adjust one or more parameters

of apparatus 10. User interface 580 can include one or more user input components (e.g. buttons, slides, knobs, and the like) and/or one or more user output components (e.g. lights, displays and the like). In some embodiments, user interface 580 includes one or more controls configured to provide a water-ingress-resistant barrier, such as controls 581 described herebelow in reference to Fig. 3A-D.

[132] Each patient programmer 600' or clinician programmer 600'' (singly or collectively programmer 600) comprises a programming device configured to control one or more components of apparatus 10. Programmer 600 can comprise a user interface 680. Programmer 600 can send and/or receive commands to and/or from one or more external devices 500 via a wireless or wired connection (wired connection not shown but such as one or more insulated conductive wires). In some embodiments, one or more external devices 500 comprise all or a portion of programmer 600, such as when all or a portion of user interface 680 is integrated into housing 510 of external device 500. In some embodiments, apparatus 10 comprises multiple programmers 600, such as one or more patient programmers 600' and/or one or more clinician programmers 600''.

[133] Programmer 600 can be configured to adjust one or more parameters of apparatus 10, such as a stimulation parameter (e.g. a stimulation waveform parameter as described herein); a sensing parameter; a therapy parameter; a data recording parameter (e.g. a patient data recording parameter and/or an implantable device 200 data recording parameter); power transfer; data rate; activity of one or more external transmitters 530; activity of one or more external antennas 540; a stimulation element 260 parameter; a functional element 299 and/or 599 parameter; and combinations of one or more of these, such as is described hereabove. Programmer 600 can be further configured to provide information, such as patient physiologic information recorded by apparatus 10 (e.g. by one or more implantable devices 200 and/or one or more external devices 500), or apparatus 10 information, such as performance and/or configuration information (singly or collectively "status information") of one or more components of apparatus 10 (e.g. one or more external devices 500 and/or implantable devices 200). In some embodiments, programmer 600 uses information recorded by one or more implantable devices 200, apparatus 10 information, and/or information from external devices 500 to adapt configuration parameters of one or more components of apparatus 10.

[134] In some embodiments, programmer 600 is configured to confirm that an adequate power transmission and/or an adequate data transmission has occurred between one or more external devices 500 and one or more implantable devices 200. In these embodiments, programmer 600 can comprise **diagnostic assembly 62** described herebelow, or otherwise be

configured to detect one or more of: power transmission to the implantable system 20 (e.g. to detect power transmission to implantable system 20 below a threshold); power transmission to the implantable system 20 trending in an undesired direction; improper and/or inadequate data transfer to the implantable system 20; and combinations of one or more of these. In some embodiments, programmer 600 monitors power transfer in real time and adjusts power transmission accordingly to optimize the rectifier efficiency (e.g. efficiency of rectifier 232 described herebelow) of one or more implantable devices 200. In some embodiments, apparatus 10 can be configured to adjust (e.g. in real time) the power transmission from one or more external devices 500 of external system 50 to one or more implantable devices 200 of implantable system 20, such as to optimize or otherwise improve an efficiency of apparatus 10, such as to improve the efficiency of transmissions between an external device 500 and an implantable device 200. These adjustments can include adjustment to one or more of: power transmission amplitude, duty cycle, frequency, phase, and periodicity.

[135] In some embodiments, programmer 600 and/or another component of apparatus 10 comprises a matching network configured to match the impedance of one or more antennas 540 to one or more transmitters 530. The matching network can comprise an adjustable matching network. The matching network can comprise a directional coupler configured to measure a reflection coefficient. A transmitter 530 can comprise an output, and a programmer 600 can be configured to monitor a standing wave pattern at the output of the transmitter 530.

[136] In some embodiments, programmer 600 comprises a lookup table of stimulation signal waveform patterns, such as to allow a clinician, patient and/or other operator of apparatus 10 to view and/or select a predetermined stimulation pattern (e.g. using user interface 680). In some embodiments, programmer 600 comprises a set of adjustable stimulation signal parameters configured to be varied to allow an operator to construct customized waveforms, such as to vary one or more stimulation parameters described hereabove. In some embodiments, programmer 600 is configured to allow an operator to create a customized waveform by specifying an amplitude of one or more discrete pulses or steps of a stimulation signal. In some embodiments, a clinician programmer 600'' can include stimulation waveform customization options not provided by a patient programmer 600'.

[137] In some embodiments, programmer 600 comprises a transmitter configured to transmit data to tool 60 or another device such as a cell phone; computer; tablet; computer network such as the internet or a LAN; and combinations of one or more of these. In these embodiments, programmer 600 can comprise a wireless transmitter; a Bluetooth transmitter; a cellular transmitter; and combinations of one or more of these. In some embodiments,

programmer 600 comprises a receiver configured to receive data, or a transceiver configured to both transmit and receive data.

[138] User interface 680 of programmer 600 can comprise one or more user input components and/or user output components, such as a component selected from the group consisting of: keyboard; mouse; keypad; switch; membrane switch; touchscreen; display; audio transducer such as a speaker or buzzer; vibrational transducer; light such as an LED; and combinations of one or more of these.

[139] In some embodiments, one or more components of external system 50 and/or other external component of apparatus 10, comprises one or more functional elements 599, such as functional elements 599a, 599b, and/or 599c, shown positioned in external device 500, programmer 600', and in programmer 600'', respectively. Each functional element 599 can comprise a functional element as defined hereabove (e.g. a sensor, a transducer, and/or other functional element as described herein). In some embodiments, a functional element 599 comprises a needle, a catheter (e.g. a distal portion of a catheter), an iontophoretic element or a porous membrane, such as an agent delivery element configured to deliver one or more agents contained (e.g. one or more agents in a reservoir, such as **reservoir 525** described herebelow) within an external device 500 and delivered into the patient (e.g. into subcutaneous tissue, into muscle tissue and/or into a blood vessel such as a vein).

[140] In some embodiments, the functional element 599 comprises an electrode for sensing electrical activity and/or delivering electrical energy. In some embodiments, apparatus 10 is configured to cause stochastic resonance, and the addition of white noise can enhance the sensitivity of nerves to be stimulated and/or boost weak signals to be recorded by the one or more stimulation elements 260.

[141] In some embodiments, one or more functional elements 599 comprise a sensor, such as a sensor configured to record data related to a patient parameter (e.g. a patient physiologic parameter), an external system 50 parameter and/or an implantable system 20 parameter. In some embodiments, operation of one or more implantable devices 200 (e.g. stimulation energy delivered by one or more implantable devices 200) is configured to be delivered based on the data recorded by one or more sensor-based functional elements 599, such as in a closed-loop energy delivery mode.

[142] Functional element 599 can comprise one or more sensors configured to record data regarding a patient parameter selected from the group consisting of: blood glucose; blood pressure; EKG; heart rate; cardiac output; oxygen level; pH level; pH of blood; pH of a bodily fluid; tissue temperature; inflammation level; bacteria level; type of bacteria present; gas level;

blood gas level; neural activity; neural spikes; neural spike shape; action potential; local field potential (LFP); EEG; muscular activity (e.g. as measured using electromyography, EMG); electrical activity produced by skeletal muscles (e.g. as measured using EMG); gastric volume; peristalsis rate; impedance; tissue impedance; electrode-tissue interface impedance; physical activity level; pain level; body position; body motion; organ motion; respiration rate; respiration level; perspiration rate; sleep level; sleep cycle; digestion state; digestion level; urine production; urine flow; bowel movement; tremor; ion concentration; chemical concentration; hormone level; viscosity of a bodily fluid; patient hydration level; and combinations of one or more of these.

[143] Functional element 599 can comprise one or more sensors configured to record data representing a parameter of external system 50 or any component of apparatus 10. Functional element 599 can comprise one or more sensors selected from the group consisting of: an energy sensor; a voltage sensor; a current sensor; a temperature sensor (e.g. a temperature of one or more components of external device 500 or programmer 600); an antenna matching and/or mismatching assessment sensor; power transfer sensor; link gain sensor; power use sensor; energy level sensor; energy charge rate sensor; energy discharge rate sensor; impedance sensor; load impedance sensor; instantaneous power usage sensor; average power usage sensor; bit error rate sensor; signal integrity sensor; and combinations of one or more of these. Apparatus 10 can be configured to analyze (e.g. via **controller 250** described herebelow) the data recorded by functional element 599 to assess one or more of: power transfer; link gain; power use; energy within power supply 570; performance of power supply 570; expected life of power supply 570; discharge rate of power supply 570; ripple or other variations of power supply 570; matching of antennas 240 and 540; communication error rate between implantable device 200 and external device 500; integrity of transmission between implantable device 200 and external device 500; and combinations of one or more of these.

[144] In some embodiments, one or more functional elements 599 are positioned on a housing 510. A functional element 599 can comprise a body conduction sensor, such as a body conduction sensor configured to record and/or receive data via skin conduction. A functional element 599 can be configured to record data associated with stimulation delivered by one or more implantable devices 200 (e.g. record data associated with stimulation energy delivered by one or more stimulation elements 260), such as to provide closed loop or semi-closed loop stimulation. A functional element 599 can be configured to record temperature, such as when apparatus 10 is configured to deactivate or otherwise modify the performance of an external device 500 when the recorded temperature (e.g. patient temperature and/or external device 500 temperature) exceeds a threshold.

[145] In some embodiments, an external device 500, programmer 600', and/or programmer 600'' comprises a temperature sensor, such as when functional elements 599a, 599b, and/or 599c, respectively, comprise a temperature sensor. The temperature-based functional element 599 can be positioned proximate a portion of programmer 600, housing 510 and/or one or more antennas 540 (e.g. to measure the temperature of one or more portions of a programmer 600 and/or external device 500). In these embodiments, the temperature data recorded by the functional element 599 is used to adjust one or more of: matching network; stimulation level (e.g. stimulation energy delivered by one or more implantable devices 200); power transmission level (e.g. level of power transmitted between one or more external devices 500 and one or more implantable devices 200); and combinations of one or more of these. In some embodiments, the temperature sensor-based functional element 599 is a part of a safety mechanism that deactivates programmer 600 and/or an external device 500 if the recorded temperature exceeds a threshold. Alternatively or additionally, a temperature sensor-based functional element 599 can be configured to measure temperature of the patient, such as when placed on housing 510, such as to adjust energy and/or agent delivery performed by implantable device 200 based on the recorded patient temperature.

[146] In some embodiments, an external device 500, programmer 600', and/or programmer 600'' comprise an accelerometer, vibration sensor, and/or other motion or shock sensor, such as when functional elements 599a, 599b, and/or 599c comprise this type of sensor. In these embodiments, the functional elements 599 can comprise a sensor configured to produce a signal used to detect when an external device 500, programmer 600', and/or programmer 600'' is dropped, as well as assess the forces generated during the drop. Alternatively or additionally, this sensor can be configured to produce a signal configured to detect a tap (e.g. on a housing) of the device, such that a tap gesture can be used in place of a control (e.g. a discrete switch) on the device.

[147] As described hereabove, implantable system 20 comprises one or more implantable devices 200, such as one or more implantable devices 200 provided sterile or configured to be sterilized for implantation into the patient. A first implantable device 200 can be of similar or dissimilar construction and arrangement to a second implantable device 200'. Each implantable device 200 can be configured to treat a patient (e.g. treat pain of the patient) and/or record patient information, such as by delivering energy and/or an agent to tissue and/or by recording one or more physiologic parameters of the patient (e.g. parameters of tissue of the patient).

[148] One or more portions of an implantable device 200 or other component of implantable system 20 can be configured to be visualized or contain a visualizable portion or

other visualizable element, such as **visualizable element 222** shown. Visualizable element 222 can comprise a material selected from the group consisting of: radiopaque material; ultrasonically reflective material; magnetic material; and combinations of one or more of these. In these embodiments, each implantable device 200 can be visualized (e.g. during and/or after implantation) via an imaging device such as a CT, X-ray, fluoroscope, ultrasound imager and/or MRI.

[149] In some embodiments, implantable system 20 comprises multiple implantable devices 200 (e.g. implantable device 200 and implantable device 200' shown in Fig. 1) and implantable system 20 comprises a "multi-point ready" system, in which the operation (e.g. energy delivery, agent deliver, data recording and/or other function) of the multiple implantable devices 200 is performed simultaneously, asynchronously, and/or sequentially. The implantable devices 200 can be part of a network including one or more external devices 500 (e.g. external device 500 and external device 500' shown in Fig. 1) in which the treating of a patient and/or the recording of patient information relies on operation of the implantable devices 200 at one or more implantation sites in a synchronized, asynchronous, and/or otherwise coordinated way. The synchronization or otherwise coordination can be controlled by a single and/or multiple external devices 500, which can further be synchronized (e.g. to a single clock). Each implantable device 200 of implantable system 20 can receive a power signal and/or a data signal from one or more external devices 500. In some embodiments of the multi-point ready implantable system 20, each implantable device 200 comprises a unique ID, such that each implantable device 200 is individually addressed (e.g. receive unique signals from external system 50). In some embodiments, external system 50 transmits high-bandwidth signals to implantable system 20, such that time-domain multiple access communication is performed while operating in near real time. In some embodiments, implantable system 20 is configured as a multi-point ready system such that stimulation energy delivered by implantable system 20 is independent of power received by implantable system 20 from external system 50.

[150] Two implantable devices 200, or two discrete components of a single implantable device 200 (e.g. two components comprising or positioned in different housings), can be attached to each other by a connecting filament as defined hereabove. In some embodiments, a connecting filament comprises a user-attachable (e.g. clinician-attachable) connector on at least one end. The filament connector is configured to operably attach to a mating connector on a component (e.g. a housing 210) of an implantable device 200.

[151] Each implantable device 200 is configured to receive power and/or data (e.g. implantable system 20 configuration data) from one or more external devices 500. In some

embodiments, one or more implantable devices 200 are configured to receive both power and data (e.g. simultaneously and/or sequentially) from one or more external devices 500. In some embodiments, a single external device 500 sends power and/or data to multiple implantable devices 200. Alternatively or additionally, a single implantable device 200 can receive power and/or data from multiple external devices 500. In some embodiments, a first external device 500 is positioned on or near the patient's skin at a location proximate an implanted first implantable device 200, and a second external device 500 is positioned on or near the patient's skin (generally "on" the patient's skin) at a location proximate an implanted second implantable device 200. In these embodiments, the first external device 500 transmits data and/or power to at least the first implantable device 200 and the second external device 500 transmits data and/or power to at least the second implantable device 200.

[152] Each implantable device 200 can comprise one or more stimulation elements 260, configured to stimulate, deliver energy to, deliver an agent to, record information from and/or otherwise interface with the patient. Alternatively or additionally, the one or more stimulation elements 260 can be configured as a sensor, such as to record patient information. Each implantable device 200 can comprise housing 210, receiver 230, **controller 250**, **energy storage assembly 270** and/or one or more antennas 240, each described in detail herein. Each stimulation element 260 can comprise a sensor and/or any transducer, as described in detail herein. One or more stimulation elements 260 can be positioned on a lead, **lead 265** shown (e.g. a flexible filament including wires or other conductors that connect each stimulation element 260 to electronics within housing 210). Each implantable device 200 can comprise one or more leads 265, such as two leads attached to a single housing 210, or a first lead 265 attached to a first housing 210 and a second lead 265 attached to a second housing 210. Each implantable device 200 can comprise one or more other functional elements, such as functional elements 299a and 299b described herein. Each implantable device 200 can further comprise one or more anchoring or other fixation elements, **anchor element 223** shown., as described in detail herebelow.

[153] In some embodiments, one or more implantable devices 200 are further configured to transmit data to one or more external devices 500, such as via one or more antennas 240 transmitting a signal to one or more antennas 540, or otherwise. Data transmitted by an implantable device 200 can comprise patient information (e.g. patient physiologic information recorded by one or more stimulation elements 260 configured as a physiologic sensor), or implantable device 200 information (e.g. data recorded by one or more stimulation elements 260

configured as a sensor and positioned in implantable device 200, or other implantable device 200 configuration and/or performance data).

[154] Housing 210 of each implantable device 200 can comprise one or more rigid and/or flexible materials which surround various components, such as antenna 240, energy storage assembly 270, controller 250 and/or receiver 230 as shown in Fig. 1. In some embodiments, one or more stimulation elements 260 are positioned in, on and/or within housing 210. In some embodiments, housing 210 surrounds a substrate, such as a flexible and/or foldable printed circuit board, such as multiple discrete or continuous printed circuit boards positioned in different planes (e.g. a flexible or foldable printed circuit board). In some embodiments, one or more antennas 240 and/or other components (e.g. a functional element 299) are positioned outside of housing 210, such as when at least one antenna 240 or other components is operably connected to one or more components (e.g. electrical components) positioned within housing 210 via a tether comprising one or more electrical conduits.

[155] Housing 210 can comprise one or more shapes or combination of shapes, such as one or more shapes selected from the group consisting of: disc; pill; cylinder; sphere; oblate spheroid; dish-like shape; bowl-like shape; cone; rectangular prism; trapezoidal prism; a portion of a toroid; and combinations of one or more of these.

[156] Housing 210 can comprise a major axis and a minor axis, defined hereabove. In some embodiments, housing 210 comprises a major axis less than or equal to 20mm, such as a major axis less than or equal to 15mm, 12mm or 10mm. In some embodiments, housing 210 comprises a minor axis less than or equal to 8mm, such as a minor axis less than or equal to 6mm, or less than or equal to 5mm. Housing 210 can comprise a wall thickness between 0.1mm and 1.0mm, such as a wall thickness between 0.2mm and 0.5mm, such as a wall thickness of approximately 0.3mm. Housing 210 can comprise a displacement volume less than or equal to 2000mm³, such as less than or equal to 600mm³.

[157] Housing 210 can comprise one or more portions that are transmissive to radiofrequency (RF) signals. In some embodiments, housing 210 comprises glass. In some embodiments, housing 210 comprises a material selected from the group consisting of: glass; ceramic; stainless steel; titanium; polyurethane; an organic compound; liquid crystal polymer (LCP); gold; platinum; platinum iridium; tungsten; epoxy; a thermoplastic; a thermoset plastic; and combinations of one or more of these. In some embodiments, one or more portions of housing 210 comprises one or more coatings, such as one or more coatings configured to cause or prevent a physiologic reaction and/or a coating configured to block (e.g. shield) an electromagnetic transmission.

[158] Housing 210 can comprise one or more passageways or other feedthroughs, such as for the passage of a lead, wire, optical fiber, fluid delivery tube, mechanical linkage and/or other conduit through a wall of housing 210, such as is described in applicant's co-pending United States Patent Application Serial Number 15/664,231, titled "Medical Apparatus Including an Implantable System and an External System ", filed July 31, 2017 [Docket nos. 47476-706.301; NAL-011-US].

[159] In some embodiments, one or more inner or outer surfaces (or portions of surfaces) of housing 210 includes an insulating and/or shielding layer (e.g. a conductive electromagnetic shielding layer), such as inner coating 219a and/or outer coating 219b shown (singly or collectively coating 219). Coating 219 can comprise an electrically insulating and/or a thermally insulating layer or other coating. In some embodiments, one or more portions of housing 210 comprise an electrically shielding coating, coating 219, while other portions are transmissive to electromagnetic signals such as radiofrequency signals.

[160] In some embodiments, housing 210 comprises an array of feedthroughs, not shown. In some embodiments, housing 210 is surrounded (e.g. partially or fully surrounded) by a covering, such as a flexible and/or non-conductive covering, such as a covering made of an elastomer.

[161] In some embodiments, implantable device 200 and/or another component of apparatus 10 can include one or more features to prevent or at least reduce migration of implant 200 within the patient's body. In some embodiments, one or more implantable devices 200 comprises one or more anchor elements configured to secure one or more portions of implantable device 200 to tissue (e.g. anchor element 223 described hereabove and/or an anchor element in an overmold positioned about a portion of housing 210). Anchor element 223 can comprise one or more anchoring elements selected from the group consisting of: a sleeve such as a silicone sleeve; suture tab; suture eyelet; bone anchor, wire loops; porous mesh; penetrable wing; penetrable tab; bone screw eyelet; tine; pincers; suture slits; and combinations of one or more of these. While anchor element 223 is shown proximate housing 210 (e.g. to fixedly attach housing 210 to tissue), in some embodiments anchor element 223 surrounds or is otherwise proximate lead 265 (e.g. to fixedly attach lead 265 to tissue), such as is described herebelow in reference to Figs. 8A-C. In some embodiments, anchor element 223 comprises a porous mesh that surrounds all or a portion of housing 210. The porous mesh can be configured to promote tissue ingrowth, such as to prevent or at least limit ("prevent" herein) migration of housing 210 when implantable device 200 is implanted in the patient. In some embodiments, anchor element 223 comprises a mesh that is attached to the top side of implantable device 200 (side in closest proximity to the

patient's skin), such as to prevent housing 210 from migrating away from the patient's skin (e.g. prevent from migrating deeper into the patient).

[162] One or more antennas 240 (singly or collectively antenna 240) can be configured to receive power and/or data, and receiver 230 can receive the power and/or data from the one or more antennas 240. Each antenna 240 can comprise one or more implantable antennas, such as one or more antennas positioned within housing 210, and/or one or more antennas electrically attached to a connecting filament. In some embodiments, one or more implantable devices 200 comprise at least two antennas 240, or at least three antennas 240. Antenna 240 can be configured to receive power and/or data from one or more external devices 500, such that an attached receiver 230 receives the power and/or data. In some embodiments, implantable system 20 comprises at least two implantable devices 200, each of which comprise one or more (e.g. two or three) antennas 240 which are positioned within a housing 210 and/or electrically tethered to a housing 210. In some embodiments, an implantable device 200 comprises a first antenna 240 positioned in a first plane and a second antenna 240 positioned in a second plane. The first plane and second plane can be relatively orthogonal planes, or planes oriented between 30° and 90° relative to each other, such as between 40° and 90°, approximately 30°, approximately 45° and/or approximately 60° relative to each other. In some embodiments, an implantable device 200 comprises a first antenna 240 positioned in a first plane, a second antenna 240 positioned in a second plane, and a third antenna 240 positioned in a third plane.

[163] In some embodiments, implantable device 200 comprises one or more antennas 240 positioned on a substrate, such as a printed circuit board (PCB), a flexible printed circuit board and/or a foldable substrate (e.g. a substrate comprising rigid portions and hinged portions). In some embodiments, the substrate is folded or otherwise pivoted to position the various antennas 240 on differently oriented planes, such as multiple planes oriented between 5° and 90° relative to each other, such as two antennas 240 positioned on two planes oriented between 30° and 90° or between 40° and 90° relative to each other, or three antennas 240 positioned on three planes oriented between 5° and 60° relative to each other. Two or more antennas 240 can be positioned on two or more different planes that are approximately 45° relative to each other, or approximately 60° or approximately 90° relative to each other.

[164] Implantable device 200 can comprise three antennas 240. In some embodiments, a first antenna 240 comprises an electrical dipole antenna, and the second and third antennas 240 can be positioned in different planes than the first antenna 240. In some embodiments, the three antennas 240 each comprise a loop antenna, such as when each loop antenna is positioned on a different plane. In some embodiments, a first antenna 240 comprises an electrical dipole

antenna, and a second antenna 240 and a third antenna 240 each comprise a loop antenna. In these embodiments, the second antenna 240 and the third antenna 240 can be positioned relatively orthogonal to each other (e.g. positioned on two relatively orthogonal planes). In some embodiments, a first antenna (e.g. an electrical dipole antenna) is positioned outside of housing 210, while a second antenna (e.g. a loop antenna) and a third antenna (e.g. a loop antenna) are each positioned on, in and/or within housing 210. In some embodiments, implantable device 200 comprises one or more antennas 240 in which any combination of antenna types (as described herein) are used in combination.

[165] One or more antennas 240 can comprise an antenna selected from the group consisting of: loop antenna; multiple-turn loop antenna; planar loop antenna; coil antenna; dipole antenna; electric dipole antenna; magnetic dipole antenna; patch antenna; loaded dipole antenna; concentric loop antenna; loop antenna with ferrite core; and combinations of one or more of these. One or more antennas 240 can comprise a loop antenna, such as an elongated loop antenna or a multiple-turn loop antenna.

[166] One or more antennas 240 can comprise a multi-turn spiral loop antenna, such as a multi-turn spiral loop antenna configured to desensitize coupling sensitivity and/or boost input voltage. In some embodiments, one or more antennas 240 comprise multiple concentric loops with varied dimensions, such as concentric loops configured to desensitize coupling sensitivity. In these embodiments, the multiple concentric loops can be arranged as follows: connected in parallel and driven from the same feed point; driven from the same feed point and connected using one or more of a capacitor, inductor, varactor, and combinations of one or more of these; and/or driven from multiple feed points.

[167] One or more antennas 240 can comprise a minor axis and a major axis. In some embodiments, one or more antennas 240 comprise a minor axis between 1mm and 8mm, such as between 2mm and 5mm. In some embodiments, one or more antennas 240 comprise a major axis between 3mm and 15mm, such as between 4mm and 8mm. In some embodiments, one or more antennas 240 comprise a major axis above 3mm, such as between 3mm and 15mm, such as when the antenna 240 is positioned outside of housing 210.

One or more antennas 240 can comprise a foldable and/or unfoldable antenna, such as is described in applicant's co-pending United States Patent Application Serial Number 14/975,358, titled "Method and Apparatus for Minimally Invasive Implantable Modulators", filed December 18, 2015 [Docket nos. 47476.703.301; NAL-005-US].

[168] One or more antennas 240 can be positioned inside of housing 210. Alternatively or additionally, one or more antennas 240 can be positioned outside of housing 210.

[169] Implantable system 20, one or more implantable devices 200 and/or one or more antennas 240 can be configured to be positioned at a desired depth beneath the patient's skin, such as at a depth between 0.5cm and 7.0cm, such as a depth of between 1.0cm and 3.0cm.

[170] One or more energy storage assemblies 270 (singly or collectively energy storage assembly 270) can comprise one or more implantable energy storage components, such as one or more batteries (e.g. rechargeable batteries) and/or capacitors (e.g. a supercapacitor). Energy storage assembly 270 can be configured to provide power to one or more of: one or more stimulation elements 260; controller 250; receiver 230; and combinations of one or more of these. In some embodiments, energy storage assembly 270 further provides power to one or more antennas 240 and/or circuitry configured to transmit data via antenna 240. In some embodiments, energy storage assembly 270 includes digital control for charge/discharge rates, voltage outputs, current outputs, and/or system power distribution and/or management.

[171] Energy storage assembly 270 can comprise one or more capacitors with a single or collective capacitance between 0.01 μ F and 10F, such as a capacitance between 1 μ F and 1.0mF, or between 1 μ F and 10 μ F. The energy storage assembly 270 can comprise one or more capacitors with capacitance between 1mF and 10F, such as when energy storage assembly 270 comprises a super-capacitor and/or an ultra-capacitor. Such large capacitance can be used to store sufficient charge to maintain operation (e.g. maintain delivery of stimulation energy and/or delivery of an agent) without the use (e.g. sufficient proximity) of an associated external device 500. A capacitor or other energy storage element (e.g. a battery) can be chosen to provide sufficient energy to maintain operation for at least 30 seconds, at least 2 minutes, at least 5 minutes, at least 30 minutes, and up to several hours or more (e.g. during showering, swimming or other physical activity). In some embodiments, energy storage assembly 270 is configured to provide continuous and/or intermittent stimulation energy for at least one charge-balanced pulse (e.g. for the duration of at least one charge-balanced pulse). In some embodiments, a capacitor, battery or other energy storage element is configured to provide stimulation energy without receiving externally supplied power for periods of at least 1 hour, at least 1 day, at least 1 month or at least 1 year. Energy storage assembly 270 can comprise one or more capacitors with a breakdown voltage above 1.0V, such as a breakdown voltage above 1.5V, 4.0V, 10V, or 15V. In some embodiments, energy storage assembly 270 can comprise capacitors distributed outside of housing 210, such as when one or more capacitors are distributed along lead 265. Energy storage assembly 270 can comprise one or more capacitors with low self-leakage, such as to maintain stored energy for longer periods of time.

[172] In some embodiments, energy storage assembly 270 comprises a temporary energy storage component, such as a super-capacitor, configured to store a sufficient quantity of energy to provide uninterrupted stimulation, such as during time periods in which the link gain may be of poor quality or it may be temporarily unavailable (e.g. an external device 500 not being in place such as during a shower, swimming, and the like). An energy storage assembly 270 comprising an ultra-capacitor, super-capacitor or flexible battery can be charged via the wireless power transmission of the present inventive concepts, such as to store a sufficient amount of energy for one or more stimulation elements 260 to deliver stimulation energy during subsequent (intended or unintended) unavailability of one or more external devices 500 (e.g. an external device 500 is intentionally removed or unintentionally falls off or otherwise loses its position sufficiently proximate one or more implantable devices 200). An energy storage assembly 270 comprising one or more high capacity energy storage components can be beneficial in applications where therapy interruption provides a significant risk or is otherwise relatively unacceptable, such as for life support therapies, cardiac resynchronization therapies, and the like. The high capacity energy storage components of energy storage assembly 270 can be positioned in an assembly positioned within housing 210, on an inner or outer surface of housing 210, within a separate housing, and/or within lead 265.

[173] In some embodiments, during use (e.g. during period of providing stimulation or other function) implantable device 200 receives power regularly from external system 50 (e.g. relatively continuously while implantable device 200 delivers stimulation energy), and energy storage assembly 270 comprises a relatively small battery or capacitor, such as a battery or capacitor that has an energy storage capacity of less than or equal to 0.6 Joules, 7 Joules or 40 Joules.

[174] One or more controllers 250 (singly or collectively controller 250) can be configured to control one or more stimulation elements 260, such as a stimulation element 260 comprising a stimulation-based transducer (e.g. an electrode or other energy delivery element) and/or a sensor (e.g. a physiologic sensor and/or a sensor configured to monitor an implantable device 200 parameter). In some embodiments, controller 250 is configured to transmit a stimulation signal (e.g. transmit stimulation energy configured in one or more stimulation waveforms) to one or more stimulation elements 260 (e.g. one or more stimulation elements 260 comprising an electrode and/or other energy delivery element), independent of the power signal received by one or more antennas 240 (e.g. independent of power transmitted by external system 50), such as by using energy stored in energy storage assembly 270. In these embodiments, the power signal and/or the RF path for the power signal can be adjusted to optimize power efficiency (e.g. by

tuning matching network on transmitter 530 and/or receiver 230; configuring antennas 540 and/or 240 in an array; tuning operating frequency; duty cycling the power signal; adjusting antenna 540 and/or 240 position; and the like), and a stimulation signal can be precisely delivered (e.g. by using energy stored on energy storage assembly 270 and generating stimulation signal locally on the implantable device 200) to ensure clinical efficacy. Also, if the power signal transmission (also referred to as “power link”) is perturbed unexpectedly, the stimulation signal can be configured so that it is not significantly affected (e.g. unaffected). In some configurations, the stimulation signal being delivered by one or more implantable devices 200 is insensitive to interference that may be present. In these embodiments, a power transmission signal and stimulation signal can vary in one or more of: amplitude; changes in amplitude; average amplitude; frequency; changes in frequency; average frequency; phase; changes in phase; average phase; waveform shape; pulse shape; duty cycle; polarity; and combinations of one or more of these.

[175] Controller 250 can receive commands from receiver 230, such as one or more commands related to one or more implantable device 200 configuration parameters selected from the group consisting of: stimulation parameter; data rate of receiver; data rate of data transmitted by the first implantable device 200 at least one implantable antenna 240; stimulation element 260 configuration; state of controller 250; antenna 240 impedance; clock frequency; sensor configuration; electrode configuration; power management parameter; energy storage assembly parameter; agent delivery parameter; sensor configuration parameter; and combinations of one or more of these.

[176] In some embodiments, one or more stimulation elements 260 comprise a stimulation element configured to deliver energy (e.g. one or more electrodes configured to deliver monopolar or bipolar electrical energy) to tissue, and controller 250 is configured to control the energy delivery, such as to control one or more stimulation parameters. Each of these stimulation parameters can be held relatively constant, and/or varied, such as a variation performed in a continuous or intermittent manner. In some embodiments, one or more stimulation parameters are varied in a random or pseudo-random (hereinafter “random”) manner, such as a variation performed by apparatus 10 using a probability distribution as described in applicant’s co-pending United States Patent Application Serial Number 16/104,829, titled “Apparatus with Enhanced Stimulation Waveforms”, filed August 17, 2018 [Docket nos. 47476-708.301; NAL-014-US]. In some embodiments, stimulation (e.g. stimulation comprising high frequency and/or low frequency signal components) is varied randomly to eliminate or at least reduce synchrony of neuronal firing with the stimulation signal (e.g. to reduce paresthesia or

other patient discomfort). In some embodiments, one or more stimulation elements 260 comprise a stimulation element configured to stimulate a target (e.g. nerve tissue such as spinal nerve tissue and/or peripheral nerve tissue). The amount of stimulation delivered to the target can be controlled by varying a parameter selected from the group consisting of: stimulation element 260 size and/or configuration (e.g. electrode size and/or configuration); stimulation element 260 shape (e.g. electrode shape, magnetic field generating transducer shape or agent delivering element shape); shape of a generated electric field; shape of a generated magnetic field; stimulation signal parameters; and combinations of one or more of these.

[177] In some embodiments, one or more stimulation elements 260 comprise an element configured to deliver electrical energy to tissue (e.g. one or more electrodes configured to deliver monopolar or bipolar electrical energy), and controller 250 is configured to control charge balance, such as to actively and/or passively control charge balance, as described herebelow. Charge balance can be essential for patient safety in electrical stimulation of nerves or other tissue. Imbalanced stimulation waveforms can cause electrode corrosion and/or dissolution which can lead to deposition of toxic materials in tissue, implant rejection, and nerve damage. The stimulation waveform can be balanced such that net outflow charge approximately equals net inflow charge. With stimulation waveform amplitudes that can vary between 0.01mA to 15mA (such as between 0.1mA and 15mA, between 0.1mA and 12mA, or between 0.1mA and 10mA), depending on the treatment, the error in charge balance can be on the order of 0.001% to 0.01%. Alternatively or additionally, controller 250 can comprise AC coupling capacitors that are configured to balance stimulation waveforms passively. The AC coupling capacitance can be fairly large (e.g. greater than 10 μ F), in order to pass the stimulation waveform with minimal filtering. In some embodiments, apparatus 10 is configured to perform active charge balancing. In some embodiments, an implantable device 200 comprises a precise resistor in series with a stimulation electrode-based stimulation element 260. The precise resistor can be used to measure outflow and inflow currents, such as when controller 250 comprises an analog to digital converter (ADC). Controller 250 can integrate current over time during a first phase in which stimulation energy is delivered, and during a second phase in which a reverse current is applied (e.g. a reverse current used to balance charge). Controller 250 can be configured to balance the total charge in the two phases, to ensure that the net DC current is approximately zero. The integration can be achieved using an analog integrator and/or a digital summer of controller 250, with controller 250 keeping track of one or more parameters of the pulses delivered (e.g. pulses delivered within a train or a burst). Implantable device 200 can comprise a precise series resistance comprising an “on-chip” trimmed resistor or an “off-chip resistor”. In some

embodiments, implantable device 200 comprises a bank of trimmed resistors that are used to control the net series resistance, such as to adjust resistance based on stimulation amplitude requirements (e.g. to take advantage of the full dynamic range of an ADC of controller 250). In some embodiments, controller 250 comprises a shunt path with an RC-based low pass filter used for both outflow and inflow of current. RC elements of controller 250 can be chosen such that the shunt current is only a fraction of the stimulation current. Since the same RC elements can be used for both outflow and inflow current, the precision required for the RC components can be lower. An ADC can be used to sense the voltage on the capacitor at the end of a stimulation pulse. After the stimulation pulse, the capacitor can be discharged and the polarity of the stimulation current can be reversed and set to any amplitude, until the capacitor is charged to approximately the same voltage (according to the ADC precision) as it was charged during the stimulation pulse. The ADC resolution can be high enough to ensure the residual error is less than what would cause an undesired charge accumulation. ADC resolution requirements can be further reduced by reducing the net capacitance in a shunt RC circuit, to cause accelerated charging of the capacitor. The capacitor can be discharged every time the voltage exceeds a certain predefined threshold, while controller 250 keeps track of the number of times the capacitor has been charged and reset. By resetting the capacitor through a low resistance path, the discharge time can be insignificant compared to the charge time, reducing the error due to the discharge period. Since the net charge equivalent to full scale voltage on the ADC can be divided into multiple cycles, the required resolution of the ADC to achieve the same residual error can be divided by the number of cycles.

[178] In some embodiments, controller 250 is configured to produce a stimulation signal comprising a waveform or a waveform pattern (hereinafter stimulation waveform), for one or more stimulation elements 260 configured as a stimulation element (e.g. such that one or more stimulation elements 260 deliver stimulation energy comprising or at least resembling that stimulation waveform). Controller 250 can produce a stimulation signal comprising a waveform selected from the group consisting of: square wave; rectangle wave; sine wave; sawtooth; triangle wave (e.g. symmetric or asymmetric); trapezoidal; ramp; waveform with exponential increase; waveform with exponential decrease; pulse shape which minimizes power consumption; Gaussian pulse shape; pulse train; root-raised cosine; bipolar pulses; and combinations of one or more of these. In some embodiments, controller 250 is configured to produce a stimulation signal comprising a waveform including a combination of two or more waveforms selected from the group consisting of: square wave; rectangle wave; sine wave; triangle wave (symmetric or asymmetric); ramp; waveform with exponential increase; waveform

with exponential decrease; pulse shape which minimizes power consumption; Gaussian pulse shape; pulse train; root-raised cosine; bipolar pulses; and combinations of one or more of these. In some embodiments, controller 250 is configured to construct a custom waveform (e.g. an operator customized waveform), such as by adjusting amplitude at specified time steps (e.g. for one or more pulses). In some embodiments, controller 250 is configured to generate a waveform including one or more random parameters (e.g. random timing of pulses or random changes in frequency, rate of change or amplitude).

[179] In some embodiments, controller 250 is configured to provide a stimulation signal comprising waveforms and/or pulses repeated at a frequency (e.g. includes a frequency component) between 1.0Hz and 50KHz, such as between 10Hz and 500Hz, between 40Hz and 160Hz and/or between 5KHz and 15KHz. In some embodiments, controller 250 is configured to produce a stimulation signal comprising a frequency between 1Hz and 1000Hz, such as a stimulation signal with a frequency between 10Hz and 500Hz. In some embodiments, controller 250 is configured to produce a stimulation signal comprising a duty cycle between 0.1% and 99%, such as a duty cycle between 1% and 10% or between 1% and 25%. In some embodiments, controller 250 is configured to produce a stimulation signal comprising a frequency modulated stimulation waveform, such as a stimulation waveform comprising a frequency component (e.g. signal) between 1kHz and 20kHz. In some embodiments, controller 250 is configured to produce a stimulation signal comprising a mix and/or modulation of low frequency and high frequency signals, which comprise any of the waveform types, shapes and other configurations. In these embodiments, the stimulation signal can comprise low frequency signals between 1Hz and 1000Hz, and high frequency signals between 600Hz and 50kHz, or between 1kHz and 20kHz. Alternatively or additionally, the stimulation signal can comprise a train of high frequency signals and bursts of low frequency signals, and/or a train of low frequency signals and bursts of high frequency signals. Alternatively or additionally, the stimulation signal can comprise one or more high frequency signals modulated with one or more low frequency signals, such as one or more high frequency signals frequency modulated (FM), amplitude modulated (AM), phase modulated (PM) and/or pulse width modulated (PWM) with one or more low frequency signals. The stimulation signal can cycle among different waveform shapes at specified time intervals. The stimulation signal can comprise a pseudo random binary sequence (PRBS) non-return-to-zero or return-to-zero waveform, such as with a fixed and/or time-varying pulse width and/or frequency of the pulses.

[180] Controller 250 can comprise a clamping circuit configured to allow fast charging and/or discharging of the energy storage assembly 270, stimulation element 260 drivers (e.g.

electrode drivers) of controller 250, and/or other components of implantable device 200. The clamping circuit can improve pulse shape by offering additional control and/or configuration of rise and fall times in the shape of the waveform (e.g. to create rapid rise or fall times). In some embodiments, the clamping circuit can be configured to limit the rise and/or fall time to be less than or equal to one-tenth (10%) of the pulse width of an applied stimulation pulse (e.g. less than or equal to 1 μ sec rise and/or fall time for a 10 μ sec stimulation pulse).

[181] In some embodiments, controller 250 comprises a matching network configured to match the impedance of a first antenna 240 with the impedance of the receiver 230. In these embodiments, controller 250's matching network can be adjustable. Alternatively or additionally, controller 250 can comprise an adjustable loading impedance to stabilize the load seen at an antenna 240 under different operating conditions. In some embodiments, the adjustable loading impedance is controlled according to the charge rate of the energy storage assembly 270.

[182] Controller 250 and/or any other component of each implantable device 200 can comprise an integrated circuit comprising one or more components selected from the group consisting of: matching network; rectifier; DC-DC converter; regulator; bandgap reference; overvoltage protection; overcurrent protection; active charge balance circuit; analog to digital converter (ADC); digital to analog converter (DAC); current driver; voltage driver; digital controller; clock generator; data receiver; data demodulator; data modulator; data transmitter; electrode drivers; sensing interface analog front end; power management circuit; energy storage interface; memory register; timing circuit; and combinations of one or more of these.

[183] One or more receivers 230 (singly or collectively receiver 230) can comprise one or more components, such as **demodulator 231**, **rectifier 232**, and/or **power converter 233** shown in Fig. 1. In some embodiments, receiver 230 can comprise a DC-DC converter such as a boost converter. Receiver 230 can comprise a data receiver, such as a data receiver including an envelope detector and demodulator and/or an envelope averaging circuit. In some embodiments, one more antennas 240 separately connect to one or more receivers 230. In some embodiments, one or more antennas 240 connect to a single receiver 230, such as via a series connection or a parallel connection.

[184] One or more implantable devices 200 can be configured to transmit a data signal to external system 50. In some embodiments, receiver 230 is configured to drive one or more antennas 240 to transmit data to external system 50 (e.g. to an antenna 540 of an external device 500). Alternatively or additionally, implantable device 200 can be configured to transmit a data signal by having receiver 230 adjust a load impedance to backscatter energy, such as a

backscattering of energy which can be detected by external system 50. In some embodiments, data transmission is accomplished by receiver 230 manipulating a signal at a tissue interface, such as to transmit a data signal using body conduction.

[185] In some embodiments, receiver 230 comprises a matching network, such as a matching network configured to detune to prevent oversaturation. For example, implantable system 20 can comprise two or more implantable devices 200 each of which includes a receiver 230 comprising a matching network. A first implantable device 200's receiver 230's matching network can be configured to detune based on power received by the second implantable device 200's receiver 230.

[186] Demodulator 231 can comprise circuitry that asynchronously recovers signals modulated on the power signal provided by external system 50, and that converts the modulated signals into digital signals. In some embodiments, demodulator 231 asynchronously recovers the modulated signal by comparing a dynamically generated moving average with the envelope, outputting a high voltage when the envelope is greater than the moving average and a low voltage when the envelope is less than the moving average. Data can then be extracted from this resulting digital signal from the width and/or amplitude of the pulses in the signal, according to the encoding method used by external system 50. In some embodiments, demodulator 231 recovers a digital signal that is used as timing information for an implantable device 200, similar to an on-chip clock. The recovered clock signal can also be used to synchronize an on-chip clock generator of controller 250, such as through the use of a frequency and/or phase locked loop (FLL or PLL).

[187] Rectifier 232 can comprise a power signal rectifier, such as to provide power to the energy storage assembly 270 and/or controller 250. In some embodiments, rectifier 232 comprises one or more self-driven synchronous rectifier (SDSR) stages connected in charge-pump configuration, to boost the voltage from input RF amplitude to the rectifier to a higher voltage. The boosted voltage can directly charge energy storage assembly 270, or it can be further boosted by a DC-DC converter or boost converter. In some embodiments, rectifier 232 comprises diode-capacitor ladder stages instead of, or in addition to, SDSR stages. On-chip diodes, such as Schottky diodes, or off-chip diodes can be used in one or more rectifier 232 stages. For maximum efficiency, the rectification elements, such as diodes, can be optimized to minimize forward conduction and/or reverse conduction losses by properly sizing the components and selecting appropriate number of stages based on the input RF voltage and load current.

[188] Power converter 233 can comprise one or more voltage conversion elements such as DC-DC converters that boost or otherwise change the voltage to a desired level. In some embodiments, voltage conversion is achieved with a buck-boost converter, a boost converter, a switched capacitor, and/or charge pumps. One or more power converters 233 can interface with energy storage assembly 270 and charge up associated energy storage components to desired voltages. In some embodiments, power converter 233 receives control signals from controller 250, such as to configure voltages, currents, charge/discharge rates, switching frequencies, and/or other operating parameters of power converter 233.

[189] One or more implantable leads 265 (singly or collectively lead 265) can be attached to one or more housings 210, such as a lead 265 comprising one or more stimulation elements 260. Lead 265 can comprise one or more stimulation elements 260 configured as a stimulation element (e.g. an electrode configured to deliver electrical energy in monopolar or bipolar mode or an agent delivery element such as an output port fluidly connected to a reservoir within housing 210). Alternatively or additionally, lead 265 can comprise one or more stimulation elements 260 and/or functional elements 299b that is configured as a physiologic sensor (e.g. an electrode configured to record electrical activity of tissue or another physiologic sensor as described herein). Alternatively or additionally, lead 265 can comprise one or more stimulation elements 260 and/or functional elements 299b that is configured to transmit signals through tissue to external system 50, such as through body conduction.

[190] In some embodiments, implantable device 200 comprises a connector, **connector 215**, that operably attaches (e.g. electrically attaches) one or more stimulation elements 260 to one or more components (e.g. electronic components) internal to housing 210 (e.g. to transfer power and/or data therebetween). Connector 215 can be constructed and arranged as described herebelow in reference to any of Figs. 13A-C and/or 14A-B. In some embodiments, connector 215 is operably attached (e.g. in a manufacturing process) or attachable (e.g. in a clinical procedure) to lead 265 as shown in Fig. 1. Alternatively, connector 215 can be operably attached and/or attachable to a lead connection assembly, **assembly 280**, which in turn can be attached to a lead 265, such as is described herebelow in reference to any of Figs. 7A-D, 13A-C, and/or 14A-B. In some embodiments, connector 215 passes through an opening in housing 210, in a feed-through arrangement. In some embodiments, an overmold or other sealing element, **sealing element 205** shown, provides a seal about connector 215, the opening in housing 210 and/or the interface between connector 215 and housing 210.

[191] In some embodiments, lead 265 comprises a removable stylet configured to aid in the implantation of lead 265, such as is described in applicant's co-pending United States Patent

Application Serial Number 15/664,231, titled "Medical Apparatus Including an Implantable System and an External System ", filed July 31, 2017 [Docket nos. 47476-706.301; NAL-011-US]. In some embodiments, implantable system 20 comprises more than one lead 265, comprising one or more stimulation elements 260 and attached to one or more housings 210 of one or more implantable devices 200. In some embodiments, one or more leads 265 can be attached to a single housing 210.

[192] In some embodiments, lead 265 comprises a diameter between 1mm and 4mm, such as a diameter between 1mm and 2mm, such as a lead with a diameter of approximately 1.35mm. In some embodiments, lead 265 comprises a length between 3cm and 60cm, such as a length between 6cm and 30cm. One or more leads 265 can include between 2-64 stimulation elements 260, such as when a lead 265 comprises between 2 and 64 electrodes, such as between 4 and 32 electrodes. In some embodiments, lead 265 comprises a paddle lead. In some embodiments, lead 265 comprises a single or multi-lumen catheter, such as when an attached implantable device 200 is configured as an agent delivery apparatus as described herein (e.g. a stimulation element 260 configured as a catheter comprises at least a portion of lead 265).

[193] In some embodiments, lead 265 comprises one or more tines, such as **tines 266** shown. Tines 266 can be configured to anchor or otherwise stabilize ("anchor" or "stabilize" herein) lead 265 relative to patient tissue, such as to prevent undesired movement during and/or after an implantation procedure for lead 265. One or more tines 266 can be configured to biodegrade after implantation in the patient, such that the stabilization provided is temporary. Tines 266 can be configured to biodegrade over a time period of approximately 4 to 12 weeks. In some embodiments, biodegradable tines 266 are configured to be incorporated when lead stimulation elements 260 are positioned to stimulate a peripheral nerve (e.g. lead 265 is implanted such that one or more stimulation elements 260 are positioned proximate one or more peripheral nerves).

[194] In some embodiments, one or more tines 266 are configured to be deployed, such as via an operator-accessible control.

[195] One or more stimulation elements 260 (singly or collectively stimulation element 260) and/or functional element 299 (e.g. functional element 299a and/or 299b) can comprise one or more sensors, transducers and/or other functional elements. In some embodiments, one or more stimulation elements 260 and/or functional elements 299 comprise at least one sensor and/or at least one transducer (e.g. a single stimulation element 260 or multiple stimulation elements 260). In some embodiments, stimulation element 260 and/or functional element 299 comprises a functional element configured to provide a therapy, such as one or more stimulation

elements 260 configured to deliver an agent to tissue (e.g. a needle or catheter), to deliver energy to tissue and/or to otherwise therapeutically affect tissue. In some embodiments, stimulation element 260 and/or functional element 299 comprises one or more functional elements configured to record patient information, such as when stimulation element 260 and/or functional element 299 comprises one or more sensors configured to measure a patient physiologic parameter, as described herein. In some embodiments, stimulation element 260 and/or functional element 299 comprises one or more sensors configured to record an implantable device 200 parameter, also as described herein.

[196] One or more stimulation elements 260 can be positioned on lead 265 as shown in Fig. 1. Alternatively or additionally, one or more stimulation elements 260 can be positioned on housing 210. One or more functional elements 299 can be positioned on lead 265 (e.g. functional element 299b shown) and/or positioned on and/or within housing 210 (e.g. functional element 299a shown).

[197] Stimulation element 260 can comprise one or more stimulation elements positioned at one or more internal body locations. Stimulation element 260 can comprise one or more stimulation elements positioned to interface with (e.g. deliver energy to and/or record a physiologic parameter from) spinal cord tissue, spinal canal tissue, epidural space tissue, spinal root tissue (dorsal or ventral), dorsal root ganglion, nerve tissue (e.g. peripheral nerve tissue, spinal nerve tissue or cranial nerve tissue), brain tissue, ganglia (e.g. sympathetic or parasympathetic) and/or a plexus. In some embodiments, stimulation element 260 comprises one or more elements positioned proximate and/or within one or more tissue types and/or locations selected from the group consisting of: one or more nerves; one or more locations along, in and/or proximate to the spinal cord; peripheral nerves of the spinal cord including locations around the back; the knee; the tibial nerve (and/or sensory fibers that lead to the tibial nerve); the occipital nerve; the sphenopalatine ganglion; the sacral and/or pudendal nerve; brain tissue, such as the thalamus; baroreceptors in a blood vessel wall, such as in the carotid artery; one or more muscles; the medial nerve; the hypoglossal nerve and/or one or more muscles of the tongue; cardiac tissue; the anal sphincter; the dorsal root ganglion; motor nerves; muscle tissue; the spine; the vagus nerve; the renal nerve; an organ; the heart; the liver; the kidney; an artery; a vein; bone; and combinations of one or more of these, such as to stimulate and/or record data from the tissue and/or location in which the stimulation element 260 is positioned proximate to and/or within. In some embodiments, apparatus 10, implantable device 200 and/or stimulation element 260 are configured to stimulate spinal nerves, peripheral nerves and/or other tissue as described in applicant's co-pending United States Patent Application Serial Number 15/916,023,

titled "Apparatus for Peripheral or Spinal Stimulation ", filed March 8, 2018 [Docket nos. 47476-707.301; NAL-012-US].

[198] In some embodiments, stimulation element 260 and/or functional element 299 comprises one or more sensors configured to record data representing a physiologic parameter of the patient. Stimulation element 260 and/or functional element 299 can comprise one or more sensors selected from the group consisting of: electrode; sensor configured to record electrical activity of tissue; blood glucose sensor; gas sensor; blood gas sensor; ion concentration sensor; oxygen sensor; pressure sensor; blood pressure sensor; heart rate sensor; cardiac output sensor; inflammation sensor; neural activity sensor; neural spike sensor; muscular activity sensor; EMG sensor, bladder volume sensor, bladder pressure sensor, gastric volume sensor; peristalsis rate sensor; pH sensor; strain gauge; accelerometer; gyroscope; GPS; respiration sensor; respiration rate sensor; flow sensor; viscosity sensor; temperature sensor; magnetic sensor; optical sensor; MEMs sensor; chemical sensor; hormone sensor; impedance sensor; tissue impedance sensor; electrode-tissue interface impedance sensor; body position sensor; body motion sensor; organ motion sensor; physical activity level sensor; perspiration sensor; patient hydration sensor; breath monitoring sensor; sleep monitoring sensor; food intake monitoring sensor; digestion monitoring sensor; urine movement sensor; bowel movement sensor; tremor sensor; pain level sensor; and combinations of one or more of these.

[199] Apparatus 10 (e.g. via stimulation element 260, functional element 299, and/or functional element 599) can be configured to record a patient parameter (e.g. patient physiologic and/or patient environment parameter) selected from the group consisting of: blood glucose; blood pressure; EKG; heart rate; cardiac output; oxygen level; pH level; pH of blood; pH of a bodily fluids; tissue temperature; inflammation level; bacteria level; type of bacteria present; gas level; blood gas level; neural activity; neural spikes; neural spike shape; action potential; local field potential (LFP); EEG; muscular activity (e.g. as measured using EMG); skeletal muscle activity; bladder volume; bladder pressure; gastric volume; peristalsis rate; impedance; tissue impedance; electrode-tissue interface impedance; physical activity level; pain level; body position; body motion; organ motion; respiration rate; respiration level; perspiration rate; sleep level; sleep cycle; digestion state; digestion level; urine production; urine flow; bowel movement; tremor; ion concentration; chemical concentration; hormone level; viscosity of a bodily fluid; patient hydration level; and combinations of one or more of these.

[200] In some embodiments, stimulation element 260 and/or functional element 299 comprises one or more sensors configured to record data representing a parameter of implantable device 200. In these embodiments, stimulation element 260 and/or functional element 299 can

comprise one or more sensors selected from the group consisting of: an energy sensor; a voltage sensor; a current sensor; a temperature sensor (e.g. a temperature of one or more components of implantable device 200); a contamination detector (e.g. to detect undesired material that has passed through housing 210); an antenna matching and/or mismatching assessment sensor; power transfer sensor; link gain sensor; power use sensor; energy level sensor; energy charge rate sensor; energy discharge rate sensor; impedance sensor; load impedance sensor; instantaneous power usage sensor; average power usage sensor; bit error rate sensor; signal integrity sensor; and combinations of one or more of these. Apparatus 10 can be configured to analyze (e.g. via implantable controller 250, programmer 600 and/or diagnostic assembly 62 described herebelow) the data recorded by stimulation element 260 and/or functional element 299 to assess one or more of: power transfer; link gain; power use; energy within energy storage assembly 270; performance of energy storage assembly 270; expected life of energy storage assembly 270; discharge rate of energy storage assembly 270; ripple or other variations of energy storage assembly 270; matching of antenna 240 and 540; communication error rate between implantable device 200 and external device 500; integrity of transmission between implantable device 200 and external device 500; and combinations of one or more of these. A stimulation element 260 can be configured to record temperature, such as when apparatus 10 is configured to deactivate or otherwise modify the performance of an implantable device 200 when the recorded temperature exceeds a threshold.

[201] In some embodiments, one or more stimulation elements 260 comprise a transducer configured to deliver energy to tissue, such as to treat pain and/or to otherwise stimulate or affect tissue. In some embodiments, stimulation element 260 comprises a stimulation element, such as one or more transducers selected from the group consisting of: an electrode; an energy delivery element such as an electrical energy delivery element, a light energy delivery element, a laser light energy delivery element, a sound energy delivery element, a subsonic sound energy delivery element and/or an ultrasonic sound delivery element; an electromagnetic field generating element; a magnetic field generating element; a mechanical transducer (e.g. delivering mechanical energy to tissue); a tissue manipulating element; a heat generating element; a cooling (e.g. cryogenic or otherwise heat extracting energy) element; an agent delivery element such as a pharmaceutical drug delivery element; and combinations of one or more of these.

[202] In some embodiments, one or more stimulation elements 260 comprises a drug or other agent delivery element, such as a needle, port, iontophoretic element, catheter, or other agent delivering element that is connected to a reservoir of agent positioned within housing 210

(e.g. **reservoir 225** described herebelow). In some embodiments, one or more stimulation elements 260 comprise a drug eluting element configured to improve biocompatibility of implantable system 20.

[203] In some embodiments, one or more stimulation elements 260 comprise one or more electrodes configured to deliver energy to tissue and/or to sense a patient parameter (e.g. electrical activity of tissue or other patient physiologic parameter). In these embodiments, one or more stimulation elements 260 can comprise one or more electrodes selected from the group consisting of: microelectrode; cuff electrode; array of electrodes; linear array of electrodes; circular array of electrodes; paddle-shaped array of electrodes; bifurcated electrodes; and combinations of one or more of these.

[204] In some embodiments, apparatus 10 (e.g. via stimulation element 260, functional element 299, and/or functional element 599) is configured to both record one or more patient parameters, and also to perform a medical therapy (e.g. stimulation of tissue with energy and/or an agent). In these embodiments, the medical therapy can be performed in a closed-loop fashion, such as when energy and/or agent delivery is modified based on the measured one or more patient physiologic parameters.

[205] In some embodiments, one or more stimulation elements 260 comprise an agent delivery element, such as a fluid delivery element (e.g. a catheter, a porous membrane, an iontophoretic element or a needle) in fluid communication with a reservoir of the agent positioned within housing 210, such as reservoir 225 described herebelow.

[206] In some embodiments, apparatus 10 comprises one or more tools, **tool 60** shown. Tool 60 can comprise a data logging and/or analysis tool configured to receive data from external system 50 or implantable system 20, such as data comprising: diagnostic information recorded by external system 50 and/or implantable system 20; therapeutic information recorded by external system 50 and/or implantable system 20; patient information (e.g. patient physiologic information) recorded by implantable system 20; patient environment information recorded by implantable system 20; and combinations of one or more of these. Tool 60 can be configured to receive data from wired or wireless (e.g. Bluetooth) means. Tool 60 can comprise a tool selected from the group consisting of: a data logging and/or storage tool; a data analysis tool; a network such as a LAN or the Internet; a cell phone; and combinations of one or more of these.

[207] In some embodiments, tool 60 comprises a battery charging assembly, such as an assembly configured to recharge one or more power supplies 570 comprising a rechargeable battery or capacitor.

[208] Apparatus 10 can include one or more placement tools, positioning **tool 67** shown, which can be configured to aid in the positioning and/or maintenance of one or more external devices 500 on the patient's skin (e.g. at a location proximate an implanted implantable device 200).

[209] Apparatus 10 can include one or more implantation tools, **tool 65** shown. Implantation tool 65 can comprise an introducer, tunneller (e.g. tunneling tool 6504 described herein), and/or other implantation tool constructed and arranged to aid in the implantation of housing 210, implantable antenna 240, lead 265 and/or one or more stimulation elements 260. In some embodiments, tool 65 comprises a component configured to anchor implantable device 200 to tissue, such as a mesh or wrap that slides around at least a portion of implantable device 200 and is configured to engage tissue (e.g. via tissue ingrowth) or be engaged with tissue (e.g. via suture or clips).

[210] In some embodiments, one or more components (and/or portions of components) of tool 65 comprises a lubricious coating and/or a lubricous material ("lubricious coating" herein), such as to reduce tissue trauma and/or reduce pain to the patient. For example, tool 65 can comprise an introducer, tunneller, pocket formation tool, needle, and/or other insertion tool with at least a portion comprising a lubricious coating configured to ease insertion of the tool. Typical coatings and materials include but are not limited to: a polytetrafluoroethylene coating or material; a hydrophilic coating or material; and combinations of these.

[211] In some embodiments, one or more components (and/or portions of components) of tool 65 comprises one or more "visualizable portions", such as a radiopaque portion that is visible in X-ray imaging (e.g. fluoroscopy) and/or ultrasonically visible portion that is visible in ultrasound imaging. For example, tool 65 can comprise an introducer including an ultrasonically visible or otherwise visible portion that is used to position the introducer, such as during the implantation of lead 265 or another portion of implantable device 200.

[212] In some embodiments, lead 265 comprises a paddle lead or other stimulating lead and tool 65 comprises an introducer (e.g. a needle or an extended-width introducer) configured to deliver at least a distal portion of lead 265 into an epidural space of a patient. Tool 65 can comprise an introducer comprising a Tuohy needle, such as a Tuohy needle of 12 gauge or smaller. Tool 65 can comprise a handle for manipulating lead 265. Tool 65 can be configured to place lead 265 at an entry point above the lumbar spinal column (e.g. between L1 and L2 vertebrae). Tool 65 can include extension tubing used to insert lead 265. Tool 65 can further comprise a tool configured to anchor lead 265, such as when tool 65 comprises sutures, clips, other anchoring elements and/or an anchor securing tool (e.g. a needle or a stapling device), such

as to secure lead 265 in subcutaneous tissue. Lead 265 and/or tool 65 can comprise extension tubing used to place lead 265, such as extension tubing that remains in place after removal of an introducer of tool 65. Tool 65 can be configured to place lead 265 against the dura of the spinal cord of the patient.

[213] In some embodiments, tool 65 and/or lead 265 are constructed and arranged to implant lead 265 to stimulate one or more multifidus (MF) muscle fascicles, such as at least three sets of multifidus muscle fascicles. Lead 265 can be secured to a vertebra (e.g. on the transverse process, lamina or vertebral body). Lead 265 can be placed via tool 65 such that one or more stimulation elements 260 (e.g. electrodes) are positioned within the multifidus muscle structures. One or more stimulation elements 260 can be positioned to deliver electrical energy and/or to otherwise stimulate tissue selected from the group consisting of: muscle motor point(s) or the deep fibers of lumbar multifidus; quadratus lumborum; the erector spinae; psoas major; transverse abdominis; connective tissue such as the annulus or facet capsule; ligaments coupling bony structures of the spine; and combinations of one or more of these. Stimulation elements 260 can be positioned to: depolarize, hyperpolarize and/or block innervated sections of the muscle that will then propagate an activating and/or inhibiting stimulus along the nerve fibers recruiting muscle tissue remote from the site of stimulation and/or modulate nerve activity (including inhibiting nerve conduction, improving nerve conduction and/or improving muscle activity). In some embodiments, stimulation elements 260 are positioned to cause transvascular stimulation (e.g. transvascular stimulation from arteries and/or veins in a leg or arm). In some embodiments, stimulation elements 260 are positioned to stimulate nerve tissue selected from the group consisting of: dorsal ramus nerve; medial branch of dorsal ramus nerve; nervous tissue associated with multifidus muscle; and combinations of one or more of these. In some embodiments, stimulation elements 260 are configured to deliver stimulation energy to contract the multifidus muscle. In some embodiments, stimulation elements 260 are configured to stimulate tissue by providing episodic electrical stimulation. In some embodiments, apparatus 10 comprises a tool 60 configured to diagnose a defect in spinal muscle or the motor control system. In some embodiments, apparatus 10 comprises a tool 60 configured to test function of the multifidus muscle, such as when tool 60 comprises an MRI; ultrasound imager; electromyogram; tissue biopsy device; and/or a device configured to test displacement as a function of load for a spine.

[214] In some embodiments, two or more external system 50 components are connected by a connecting filament, such as is described hereabove. Alternatively or additionally, two or more implantable system 20 components are connected by a conduit, such as a connecting filament as

described herein. Alternatively or additionally, two more external system 50 components and/or two or more implantable system 20 components transmit information and/or power via a wireless transmitter (e.g. an RF transmitter), magnetic coupling, inductive coupling; capacitive coupling and/or other wireless transmission means.

[215] Apparatus 10 can include one or more positioning devices, such as **patient attachment device 70** shown in Fig. 1, that is used to attach one or more components of external system 50 to a location on or at least proximate the patient. In some embodiments, patient attachment device 70 is constructed and arranged as described in applicant's co-pending United States Patent Application Serial Number 16/408,989, titled "Method and Apparatus for Neuromodulation Treatments of Pain and Other Conditions ", filed May 10, 2019 [Docket nos. 47476.705.302; NAL-008-US-CON1].

[216] Patient attachment device 70 can comprise one or more elements configured to attach one or more external devices 500 and/or programmer 600 at one or more locations on or proximate the patient's skin, that are relatively close to one or more implantable devices 200 that have been implanted in the patient. Patient attachment device 70 can comprise a component selected from the group consisting of: belt; belt with pockets; belt with adhesive; adhesive; strap; strap with pockets; strap with adhesive shoulder strap; shoulder band; shirt; shirt with pockets; clothing; clothing with pockets; epidural electronics packaging; clip (e.g. **patient attachment device 70a** described herebelow in reference to Fig. 3A-D); bracelet; wrist band; wrist watch; anklet; ankle bracelet; knee strap; knee band; thigh strap; thigh band; necklace; hat; headband; collar; glasses; goggles; earpiece; behind-the-earpiece; and combinations of one or more of these. In some embodiments, patient attachment device 70 comprises a belt configured to surround at least one antenna 540 (e.g. at least one antenna 540 mounted to or otherwise positioned on a printed circuit board such as a flexible printed circuit board). Patient attachment device 70 can include one or more pockets, such as one or more pockets configured to collectively surround one or more of: external device 500; one or more antennas 540; power supply 570; programmer 600; and combinations of one or more of these. In some embodiments, patient attachment device 70 comprises multiple pockets, such as to allow repositioning of an external antenna 540, programmer 600, external transmitter 530 and/or external power supply 570 to various different locations, such as to improve transmission of power and/or data to one or more implantable devices 200 and/or improve patient comfort. In some embodiments, one or more antennas 540, power supplies 570, and/or transmitters 530 are connected through flexible cables positioned in patient attachment device 70. In some embodiments, the flexible cables are small coax cables that accommodate the power levels and frequencies of the carried signals. In

some embodiments, the one or more antennas 540 are connected to one or more additional components of external device 500 through a single cable with a local power splitting component and/or active matching element that adjusts signal power to each of the one or more antennas 540.

[217] In some embodiments, patient attachment device 70 and/or external device 500 can be configured to prevent adversely affecting portions of the skin contacted by either device. Alternatively or additionally, patient attachment device 70 and/or external device 500 can be configured to clean and/or to promote healing of one or more skin-contacting portions. For example, patient attachment device 70 can include an agent (e.g. a coating or other included agent) selected from the group consisting of: a bactericidal agent; an anti-fungal agent; and combinations thereof.

[218] In some embodiments, an anchoring-based tool, patient attachment device 70, is used on a patient-by-patient basis, such as when used on overweight patients and/or to otherwise avoid migration of implantable device 200 sideways and/or downward (e.g. into fat tissue).

[219] Apparatus 10 can comprise a device configured to operate (e.g. temporarily operate) one or more implantable devices 200, such as **trialing interface 80** shown in Fig. 1. Trialing interface 80 can be configured to wirelessly deliver power to an implantable device 200, wirelessly deliver data to an implantable device 200, and/or wirelessly receive data from an implantable device 200. Trialing interface 80 can be configured to interface with one or more implantable devices 200 during an implantation procedure in which one or more implantable devices 200 are implanted in a patient (e.g. a sterile clinical procedure in which an implantable device 200 comprising a pre-attached lead 265 is implanted in a patient). Trialing interface 80 can be configured to be sterilized one or more times. Trialing interface 80 can comprise one or more antennas, such as an antenna similar to antenna 540 of an external device 500. Trialing interface 80 can comprise a transmitter, such as a transmitter similar to transmitter 530 of external device 500, and a power supply, such as a power supply similar to power supply 570 of external device 500. In some embodiments, trialing interface 80 is of similar construction and arrangement to the trialing interface described in applicant's co-pending United States Patent Application Serial Number 16/408,989, titled "Method and Apparatus for Neuromodulation Treatments of Pain and Other Conditions ", filed May 10, 2019 [Docket nos. 47476.705.302; NAL-008-US-CON1]. In some embodiments, trialing interface 80 includes a housing to be positioned proximate at least a portion of implantable device 200, such as a housing 210 that surrounds an antenna and a transmitter that is configured to operatively couple to (e.g. transmit power and/or data to) one or more antennas 240 of one or more implantable devices 200.

[220] In some embodiments, trialing interface 80 is constructed and arranged as described an applicant's co-pending United States Patent Application Serial Number 16/672,921, titled "Stimulation Apparatus", filed November 4, 2019 [Docket nos. 47476-714.301; NAL-020-US].

[221] As described hereabove, trialing interface 80 can be used in clinical procedures in which an implantable device 200 including a pre-attached lead 265 is implanted. In some embodiments, implantable device 200 includes an attachable lead 265, and apparatus 10 includes trialing interface 90. Trialing interface 90 can be configured to operably (e.g. electrically) attach to lead 265, such as to deliver stimulation energy via a wired connection during a trialing procedure, as described herein. For example, trialing interface 90 can deliver stimulation energy to one or more stimulation elements 260 of lead 265 during a trialing procedure in which proper position of stimulation element 260 is confirmed and/or modified, and/or one or more stimulation waveforms are tested. Trialing interface 90 can include an interface connector 95 configured to operably attach (e.g. electrically attach) trialing interface 90 to lead 265 (e.g. after lead 265 has been implanted in tissue of the patient). Connector 95 can be configured to be used in a single trialing procedure (e.g. on a single patient), while the remainder of trialing interface 90 can be reused (e.g. in multiple trialing procedures for multiple patients). Trialing interface 90 can comprise a device that is sterilized, and it can be a device that can be re-sterilized (e.g. to be used in multiple sterile clinical procedures). In some embodiments, interface connector 95 and other portions of trialing interface 90 are constructed and arranged as described herebelow in reference to Figs. 12A-B. In some embodiments, trialing interface 80 and trialing interface 90 include similar components, (e.g. similar components used to create similar stimulation waveforms to be used in a trialing procedure).

[222] In some embodiments, one or more implantable devices 200 of implantable system 20 comprises an implantable transmitter configured to transmit data, such as to transmit data (e.g. stimulation information, patient physiologic information, patient environment information, implantable device 200 performance and/or configuration information, and the like) to one or more external devices 500. In these embodiments, receiver 230 can be configured as both a receiver and a transmitter. One or more implantable devices 200 can be configured to transmit data by sending a signal to (i.e. "driving") one or more antennas 240 or another antenna of implantable device 200. An implantable device 200 can be configured to transmit data using one or more of: load modulation; a signal carrier; and/or body conduction. An implantable device 200 can be configured to adjust the transmission, such as to adjust a data transmission parameter selected from the group consisting of: data rate; pulse width; duration of carrier signal; amplitude

of carrier signal; frequency of carrier signal; configurable load; and combinations of one or more of these.

[223] In some embodiments, apparatus 10 comprises a diagnostic assembly, **diagnostic assembly 62** shown in Fig. 1. In some embodiments, programmer 600 and/or implantable controller 250 comprise all or a portion of diagnostic assembly 62. Diagnostic assembly 62 can be configured to assess, monitor, determine and/or otherwise analyze patient information and/or implantable device 200 information, such as when one or more stimulation elements 260, functional elements 299, and/or functional elements 599 are configured as a sensor configured to record patient information (e.g. patient physiologic information and/or patient environment information) and/or apparatus 10 information (e.g. implantable device 200 information) as described herein. Diagnostic assembly 62 can be configured to analyze communication and/or the power link between an implantable device 200 and an external device 500. In some embodiments, such a communication link analysis can be performed by measuring bit error rate (BER) of a known data stream during communication signal transmission (also referred to as “communication link”) measurement phase (e.g. such as during a calibration procedure). The BER can be tracked by the implant controller 250 or programmer 600, such as to monitor and keep track of any trends in the link. This trend can be used to adjust the link and/or provide feedback to an operator of apparatus 10 (e.g. the patient), in case the link cannot be automatically adjusted to compensate for a negative trend (e.g. such that the operator can perform physical re-adjustment of the external system 50). Alternatively or additionally, a power link analysis can be performed by monitoring charge/discharge rate of the implanted energy storage assembly 270. Similar to the communication link, the power link status and/or trending can be monitored and recorded for link adjustment and/or feedback purposes. Diagnostic assembly 62 can be configured to analyze a result of stimulation energy delivered by implantable device 200, such as when a stimulation element 260 comprises an electrode to record electrical activity of tissue (e.g. in addition to delivering electrical energy to stimulate tissue). A stimulation element 260, a functional element 299, and/or a functional element 599 can comprise a sensor configured to record neural activity and/or muscular activity, and the diagnostic assembly configured to analyze the recorded sensor data. In some embodiments, diagnostic assembly 62 is configured to analyze impedance, such as when a stimulation element 260, a functional element 299, and/or functional element 599 comprises a sensor configured to record data related to impedance, such as when implantable device 200 performs a frequency sweep, performs an impulse response and/or compares voltage and current of a stimulation waveform. In some embodiments, diagnostic assembly 62 is configured to assess the impedance of one or more implantable

antennas 240 and/or one or more external antennas 540. In these embodiments, impedance can be assessed by performing a function selected from the group consisting of: performing a frequency sweep; performing an impulse response; comparing voltage and current of a waveform; and combinations of one or more of these.

[224] In some embodiments, diagnostic assembly 62 is configured to test or otherwise assess the link between one or more implantable antennas 240 and one or more external antennas 540 (e.g. during a procedure in which one or more implantable devices 200 are implanted in a patient). In these embodiments, diagnostic assembly 62 can be configured to perform a test prior to anchoring housing 210 to tissue (e.g. prior to initial or final suturing into tissue such as the fascia layer). For example, lead 265 can be implanted at a location to stimulate target tissue (e.g. one or more nerves identified to treat pain or another patient condition). Prior to suturing housing 210 in its implant location, diagnostic assembly 62 can be configured to confirm that one or more external antenna 540 transmission links to one or more implantable antennas 240 are above an efficiency threshold, for example such that sufficient power will be received by the one or more implantable devices 200. Additionally, the procedure can be performed to optimize or otherwise improve the position of the one or more implantable devices 200 to be implanted and subsequently secured to tissue.

[225] In these link testing embodiments, diagnostic assembly 62 can comprise a handheld assembly (e.g. a sterile assembly comprising a wand or other handheld housing). Diagnostic assembly 62 can be configured to send a simple signal to one or more implantable devices 200 (e.g. a diagnostic assembly 62 with similar power and/or data transmission capabilities as an external device 500). Each implantable device 200 can respond (e.g. via data sent via an implantable antenna 240 or other transmitter) with information related to the quality of the transmission link (e.g. information about the power received by the one or more implantable devices 200). Diagnostic assembly 62 could provide a user interface (e.g. a speaker, a text screen and/or a video display) that provides quality or other information (go/no go information, digital or other discrete level information, and/or analog information). Diagnostic assembly 62 could be further configured to provide information confirming detection of one or more implantable devices 200, status of one or more implantable devices 200 (e.g. parameter level and/or fault detection status), and/or self-diagnostic status (i.e. diagnostic assembly 62 status).

[226] Each implantable device 200 can be configured to specifically identify and/or specifically reply to diagnostic assembly 62 (e.g. in a different form than communications with an external device 500). Each implantable device 200 can be configured to provide information related to one or more of: the charge and/or discharge rate of energy storage assembly 270 (e.g.

the charge and/or discharge rate of a capacitor or battery of energy storage assembly 270); or the frequency of a voltage-controlled oscillator that is driven by an unregulated voltage of power converter 233. Diagnostic assembly 62 can be configured to perform numerous performance tests (e.g. of one or more implantable devices 200 or implantation locations for one or more implantable devices 200), prior to completion of the implantation procedure (e.g. prior to closing one or more incisions).

[227] In some embodiments, apparatus 10 is configured to provide a therapy by delivering stimulation energy to tissue, such as electrical energy delivered to tissue by one or more stimulation elements 260 comprising one or more electrodes. Alternatively or additionally, apparatus 10 can be configured as an agent-delivery apparatus (e.g. a pharmaceutical or other agent delivery apparatus). In some embodiments, apparatus 10 comprises one or more reservoirs for storing the agent, such as **reservoir 525** of external device 500 and/or **reservoir 225** of implantable device 200, each shown in Fig. 1. Reservoirs 525 and/or 225 can be fluidly connected to one or more functional elements 599 and/or functional elements 299, respectively (e.g. via one or more tubes). Reservoirs 525 and/or 225 can comprise one or more chambers (e.g. independent chambers configured to separately contain incompatible drugs or otherwise prevent undesired multiple drug interactions). Reservoirs 525 and/or 225 can comprise a volume (e.g. a volume to store one or more agents) between 0.1ml and 50ml, such as between 0.1 ml and 3.0ml, or between 0.1ml and 1.0ml. Reservoirs 525 and/or 225 can comprise pressurized reservoirs or otherwise comprise a fluid pumping mechanism (e.g. a peristaltic mechanism, syringe pump or other fluid pump). Reservoirs 525 and/or 225 and can comprise refillable reservoirs (e.g. when reservoir 225 of an implantable device 200 comprises a valved opening such as a silicone septum or a mechanical valve, either accessible via a needle for refilling). The fluidly attached functional elements 599 and/or functional elements 299 can comprise a fluid delivery element selected from the group consisting of: a catheter; a porous membrane; an iontophoretic element; a needle; or combinations of one or more of these. Delivered and/or stored (e.g. in a reservoir) agents can comprise an agent selected from the group consisting of: an analgesic agent such as morphine, fentanyl, lidocaine or other agent delivered to treat pain; a chemotherapeutic agent such as a chemotherapeutic agent delivered systemically (e.g. throughout the blood system of the patient) and/or to a location in or proximate an organ such as the liver or brain to treat cancer; an antibiotic configured to treat or prevent an infection; a hormone such as a hormone delivered intravenously in hormonal therapy; heart medications such as nitroglycerin, a beta blocker or a blood pressure lowering medication; a carbohydrate such as glucose or dextrose delivered to treat a low blood sugar condition; insulin such as to treat a high

blood sugar condition; a diabetic medication; a neurological medication; an epilepsy medication; and combinations of one or more of these. In some embodiments, apparatus 10 comprises the one or more agents stored in reservoir 225 and/or 525. In some embodiments, apparatus 10 is constructed and arranged to deliver the agent (e.g. via a catheter-based functional element 599, functional element 299, and/or stimulation element 260) to a patient location selected from the group consisting of: a vessel; a blood vessel; a vein; an artery; heart; brain; liver; spine; epidural space; intrathecal space; subcutaneous tissue; bone; intraperitoneal space, intraventricular space, and combinations of one or more of these.

[228] In some embodiments, an external device 500 is attached to the patient via a patient attachment device 70 comprising a wrist band, wrist watch, leg band, ankle band or other band configured to position an external device 500 about a limb of the patient (i.e. arm or leg of the patient). In these embodiments, one or more implantable devices 200 are implanted under the skin proximate the intended (limb) location of external device 500 and patient attachment device 70. Apparatus 10 can be configured such that external device 500 comprises one or more antennas 540; one or more implantable devices 200 each comprise one or more antennas 240; and each implantable device 200 one or more antennas 240 receive power and/or data from the one or more antennas 540 of the limb-attached external device 500. The limb-attached external device 500 can comprise one or more reservoirs 525 described hereabove and/or one or more functional elements 599 configured as agent delivery elements and/or sensors. The one or more implantable devices 200 can comprise one or more reservoirs 225 described hereabove and/or one or more stimulation elements 260 configured as agent delivery elements and/or sensors.

[229] In some embodiments, apparatus 10 comprises an agent delivery apparatus and agent is delivered into the patient (e.g. into a blood vessel, muscle or subcutaneous tissue) by an external device 500 functional element 599 (e.g. a needle) based on signals recorded by an implantable device 200 functional element 299 and/or stimulation element 260 (e.g. a sensor). Alternatively or additionally, agent can be delivered into the patient (e.g. into a blood vessel, muscle or subcutaneous tissue) by an implantable device 200 stimulation element 260 (e.g. a needle, catheter, porous membrane or iontophoretic delivery element). The amount of agent delivered by stimulation element 260 can be based on signals recorded by an implantable device 200 stimulation element 260 (e.g. a sensor) and/or an external device 500 functional element 599a (e.g. a sensor). External device 500 can provide power to one or more implantable devices 200 and/or it can send data (e.g. sensor data from a functional element 599) to implantable device 200, such as to control agent delivery by implantable device 200.

[230] Apparatus 10 can be configured to prevent an electromagnetic field (e.g. an electromagnetic field produced by one or more devices not included in apparatus 10 and/or other present in the patient environment) from adversely affecting and/or otherwise affecting the patient treatment and/or patient information recording (e.g. patient tissue stimulation and/or patient physiologic information gathering) performed by apparatus 10. Electromagnetic fields from one or more apparatus 10 devices and/or otherwise present in the patient environment can potentially interfere with apparatus 10. The architecture of the wireless signal transmissions of apparatus 10 can be configured to include certain unique and/or identifiable patterns in the signals transmitted by apparatus 10 to confirm (upon receipt) that the signal originated from a component of apparatus 10. Alternatively or additionally, the stimulation signal produced by an implantable device 200 can be created independent from a power signal received from an external device 500, so that any electromagnetic interference in the wireless link does not affect generation and delivery of the stimulation signal. In some embodiments, each implantable device 200 and/or external device 500 includes unique identification codes that are required to be transmitted prior to any changes in stimulation or other implantable device 200 configuration, ensuring correct operation in the presence of interference. Alternatively or additionally, the communication link can incorporate handshaking protocols, confirmation protocols, data encryption and/or scrambling, coding and other security measures to ensure that interfering signals do not adversely affect the implantable system 20 performance (e.g. stimulation). In some embodiments, external system 50 and/or implantable system 20 incorporate electromagnetic absorptive and/or reflective materials to minimize external interference from other sources and/or minimize the probability of apparatus 10 interfering with other systems. Alternatively or additionally, apparatus 10 can incorporate error detection and protocols for entering an alarm state (e.g. and shutting down normal operation) and/or otherwise ensuring safe operation.

[231] In some embodiments, implantable system 20 of apparatus 10 is configured to perform magnetic field modulation, such as targeted magnetic field neuromodulation (TMFN), electro-magnetic field neuromodulation, such as targeted electro-magnetic field neuromodulation (TEMFN), transcutaneous magnetic field stimulation (TMS), or any combination of these. Each implantable device 200, via one or more of its stimulation elements 260 (e.g. electrodes) can be configured to provide localized (e.g. targeted) magnetic and/or electrical stimulation. Combined electrical field stimulation and magnetic field stimulation can be applied by using superposition, and this combination can reduce the overall energy requirement. In some embodiments, implantable apparatus 10 comprises one or more stimulation elements 260 comprising a

magnetic field generating transducer (e.g. microcoils or cuff electrodes positioned to partially surround or otherwise be proximate to one or more target nerves). Stimulation elements 260 comprising microcoils can be aligned with nerves to minimize affecting non-targeted tissue (e.g. to avoid one or more undesired effects to non-target tissue surrounding or otherwise proximate the target tissue). In some embodiments, the target tissue comprises dorsal root ganglia (DRG) tissue, and the non-target tissue comprises ventral root tissue (e.g. when the stimulation energy is below a threshold that would result in ventral root tissue stimulation).

[232] In some embodiments, external system 50 of apparatus 10 is configured to provide mechanically adjustable alignment of one or more external antennas 540 alignment. Link gain between one or more external antennas 540 and one or more implantable antennas 240 can degrade over time due to physical misalignment of the antennas, relative orientation changes between antennas and/or relative angular misalignment between antennas. In order to compensate for misaligned antennas, electrical beam steering can be included in apparatus 10. Antennas comprising a multi-feed antenna structure and/or those comprising an array of antennas can be incorporated (e.g. into external antenna 540, implantable antenna 240 or both) for electrical beam steering. Alternatively or additionally, mechanical antenna steering can be implemented to physically realign one or more external antennas 540 with one or more implanted antennas 240 (or vice versa). A substrate of an implantable antenna 240 and/or an external antenna 540 can be flexible and/or rigid (e.g. a substrate comprising polyamide, polyimide, liquid crystal polymer (LCP), Rogers, FR4, or a similar material). One or more antennas 540 can be connected to electronics (e.g. a transmitter, receiver or transceiver) using a flexible waveguide or cable (e.g. 50 ohm 0.047" coaxial cable designed to provide patient comfort) and/or a flexible PCB substrate transmission line. Mechanical or physical realignment of antennas 240 and/or 540 can be accomplished using one or more of: use of motorized positioners, such as a mechanism including one or more small pulleys and/or tensioners used to translate one or more antennas 240 and/or 540 about one or more axes; an actuator (e.g. a piezoelectric actuator) with directional gears configured to translate one or more antennas 240 and/or 540 about one or more axes; a micro-pump with fluid reservoir (e.g. liquid or gas reservoir) configured to hydraulically and/or pneumatically translate one or more antennas 240 and/or 540 about one or more axes, such as by creating a local pressure difference. In some embodiments, a micro-pump with fluid reservoir is used to move one or more antennas 240 and/or 540, such as to move an external antenna 540 away from tissue to reduce specific absorption rate (SAR). In these embodiments, external antenna 540 can be positioned in mechanical contact with an expandable reservoir (e.g. a balloon) positioned between external

antenna 540 and tissue. The reservoir can be inflated or deflated to control separation distance of the external antenna 540 from the patient's skin surface. In some embodiments, apparatus 10 comprises one or more algorithm positioning algorithms, algorithm 15, beam steering functionality and/or mechanical antenna steering as described in applicant's co-pending United States Patent Application Serial Number 14/975,358, titled "Method and Apparatus for Minimally Invasive Implantable Modulators", filed December 18, 2015 [Docket nos. 47476.703.301; NAL-005-US], and United States Patent Application Serial Number 15/664,231, titled "Medical Apparatus Including an Implantable System and an External System ", filed July 31, 2017 [Docket nos. 47476-706.301; NAL-011-US], the content of each of which is incorporated herein in its entirety for all purposes.

[233] In some embodiments, implantable system 20 of apparatus 10 is configured to provide paresthesia-reduced (e.g. paresthesia-free) high frequency pain management and rehabilitation therapy (e.g. via delivery of a stimulation signal above 600Hz or 1kHz, or other stimulation signal resulting in minimal paresthesia). Apparatus 10 can be configured to provide both low frequency (e.g. <1kHz) stimulation and high frequency stimulation, such as when providing low frequency stimulation to elicit feedback from a patient during intraoperative or other (e.g. post-implantation) stimulation configuration. For example, trialing interface 80 and/or 90 can be used during an intra-operative titration of stimulation configuration using low frequency stimulation (e.g. to position and/or confirm position of one or more stimulation elements 260, such as to confirm sufficient proximity to target tissue to be stimulated and/or sufficient distance from non-target tissue not to be stimulated). In some embodiments, high frequency stimulation is delivered to reduce pain over extended periods of time, and low frequency stimulation is used in these intraoperative and/or post-implantation titration or other stimulation configuration procedures. Intentional elicitation of paresthesia (e.g. via low frequency stimulation and/or high frequency stimulation) is beneficial during stimulation element 260 (e.g. electrode) implantation because a patient can provide feedback to the implanting clinician to ensure that the stimulation elements 260 are positioned close to the target neuromodulation or energy delivery site. This implantation position-optimizing procedure can advantageously reduce the required stimulation energy due to stimulation elements 260 being closer to target tissue, since a minimum threshold for efficacious stimulation amplitude is proportional to the proximity of stimulation elements 260 to target tissue (e.g. target nerves). The patient can inform the clinician of the sensation of paresthesia coverage, and the clinician can adjust stimulation element 260 position to optimize stimulation element 260 location for efficacious treatment while minimizing unintentional stimulation of non-target tissue (e.g. motor

nerves or other nerves which are not causing the patient's pain). These paresthesia-inducing techniques (e.g. using low frequency stimulation and/or high frequency stimulation) can be used during or after implantation of one or more implantable devices 200.

[234] In some embodiments, apparatus 10 is configured to deliver low frequency stimulation energy (e.g. electrical energy comprising a low frequency signal) to stimulate motor nerves, such as to improve tone and structural support (e.g. physical therapy). In these embodiments, apparatus 10 can be further configured to provide high frequency stimulation, such as to treat pain (e.g. suppress and/or control pain). The combined effect can be used not only for pain management but also muscle strengthening and gradual healing of supportive structures. Alternatively or additionally, as described herein, apparatus 10 can be configured to deliver low frequency stimulation energy (e.g. electrical energy) to induce paresthesia, which can also be accompanied by the delivery of high frequency stimulation (e.g. to suppress and/or control pain). In some embodiments, apparatus 10 is configured to deliver low frequency stimulation (e.g. electrical energy comprising a low frequency signal) and burst stimulation, delivered simultaneously or sequentially. The low frequency stimulation and the burst stimulation can be delivered on similar and/or dissimilar stimulation elements 260 (e.g. similar or dissimilar electrode-based stimulation elements 260).

[235] As described herein, apparatus 10 can be configured for treating numerous disease and disorders, such as when apparatus 10 is configured to deliver electrical or other stimulation energy to treat pain (e.g. by delivering electrical or other energy to the spine or other neural location). Apparatus 10 can be configured to stimulate tissue with various stimulation waveforms, such as those described in applicant's co-pending United States Patent Application Serial Number 16/104,829, titled "Apparatus with Enhanced Stimulation Waveforms", filed August 17, 2018 [Docket nos. 47476-708.301; NAL-014-US].

[236] Apparatus 10 can be configured to treat neuropathy, neuralgia and/or other nerve pain that is related to: surgery; trauma; infection (e.g. a herpetic infection); and/or diabetes (e.g. diabetic neuropathy). One or more stimulation elements 260 can be configured to deliver stimulation energy (e.g. electrical energy, magnetic energy, light energy, thermal energy, sound energy, and/or chemical energy (e.g. energy from a drug or reagent) to nerve tissue such as tissue of the central nervous system and/or peripheral nervous system. One or more leads 265 (each comprising one or more stimulation elements 260) can be implanted in and/or proximate the spinal cord, the groin and/or a joint such as the hip. For example, apparatus 10 can be configured to treat one or more of: post-surgical neuralgia (e.g. following hernia repair such as a hernia repair including an implanted mesh); headache (e.g. due to occipital neuralgia); post-

herpetic neuralgia; chronic pelvic and/or hip pain; knee pain; and combinations of one or more of these.

[237] To treat pain related to hernia or hernia repair, one or more stimulation elements 260 (e.g. on a lead 265 and/or on a housing 210) can be positioned to stimulate tissue of the peripheral nervous system and/or the central nervous system. In some embodiments, one or more stimulation elements 260 are positioned to stimulate the cutaneous branch of the ilioinguinal, inguinal and/or genital branch of the genitofemoral nerves. In some embodiments, one or more stimulation elements 260 are positioned to stimulate corresponding branches of spinal nerves correlating to one or more dermatomes related to pain associated with at least one of hernia or hernia repair.

[238] Hernia or hernia repair can lead to: inguinal pain; ilioinguinal neuralgia; post-traumatic neuropathic pain; ilioinguinal nerve entrapment; neuropathic pain of ilioinguinal origin; post-surgical inguinal pain; genitofemoral pain; genitofemoral neuralgia; genitofemoral nerve entrapment; neuropathic pain of genitofemoral origin; post-surgical genitofemoral pain; iliohypogastric pain; iliohypogastric neuralgia; iliohypogastric nerve entrapment; neuropathic pain of iliohypogastric origin; post-surgical iliohypogastric pain; testicular pain; scrotal pain; penis pain; groin pain; thigh pain; anal pain; rectal pain; perineal pain; abdominal adhesions; pelvic adhesions; scar pain; diffuse polyneuropathy; and combinations of one or more of these. In some embodiments, apparatus 10 is configured to treat hernia pain by delivering a low frequency stimulation signal (e.g. an electrical signal less than or equal to 1kHz delivered by one or more electrode-based stimulation elements 260). Alternatively or additionally, apparatus 10 can treat hernia pain with a high frequency stimulation signal, such as a signal comprising a frequency greater than 1kHz. Stimulation can be accomplished either via subcutaneous field stimulation and/or by stimulation elements 260 positioned adjacent or at least near the nerves and/or their branches. In some embodiments, stimulation is accomplished transvascularly (e.g. stimulation including low and/or high frequencies).

[239] The apparatus of the present inventive concepts can be configured to stimulate the ilioinguinal nerve, genitofemoral nerve and/or iliohypogastric nerves, such as to ameliorate pain following hernia repair. One or more leads 265 (e.g. one or more leads 265 comprising one or more electrode-based or otherwise stimulation-based stimulation elements 260) can be inserted over the inguinal region (which may include the inguinal ring) to stimulate any or all three of these nerves (e.g. in a unilateral or bilateral fashion). Both the ilioinguinal and genital branch of the genitofemoral nerves pass through the inguinal ring. The anterior cutaneous iliohypogastric and femoral branch of the genitofemoral nerve can be stimulated at one or more locations

proximate but rostral (iliohypogastric) or lateral (genitofemoral) to the inguinal ring. Leads 265 can comprise one or more stimulation elements 260 comprising cylindrical, paddle, cuff and/or hemi-cuff electrodes (electrodes placed surgically near and/or around these nerves). The nerves can be localized via ultrasound or other imaging modalities. Contrast can be used to image the vessels nearby (e.g. the testicular and/or ovarian vein and/or artery). The genital branch of the genitofemoral nerve can be stimulated in a transvascular manner through the testicular vein and/or artery. The genitofemoral and/or the ilioinguinal nerves can also be stimulated (e.g. transvascularly stimulated) through the femoral vein and/or artery, or via the superficial or deep external pudendal vein and/or artery, and/or via the superficial epigastric vein and/or artery.

[240] The painful areas innervated by the ilioinguinal nerve, genitofemoral nerve and/or iliohypogastric nerves, can also be treated via spinal cord stimulation provided by apparatus 10 in the L1-L5 region of the spinal cord. In some embodiments, direct stimulation of the L1-L2 dorsal root ganglia is provided in a similar treatment. Leads 265 (e.g. percutaneous or paddle) including stimulation-based stimulation elements 260 can be placed over the dorsal columns, over the dorsal roots and/or in the dorsal root entry zone, in a unilateral, bilateral and/or midline fashion.

[241] To treat occipital neuralgia, also known as C2 neuralgia, one or more stimulation elements 260 can be positioned to stimulate peripheral nerve tissue to reduce pain. Occipital neuralgia is a medical condition characterized by chronic pain in the upper neck, back of the head and/or behind the eyes (areas corresponding to the locations of the lesser and greater occipital nerves). In some embodiments, one or more leads 265, each comprising one or more stimulation elements 260, are implanted transversely, either unilaterally or bilaterally, at the level of the appropriate target cervical nerve (C1, C2, etc.). The C1, 2, 3 cervical roots include the greater occipital nerve which originates primarily from C2, and the lesser occipital nerves. Relevant trigeminal branches include both the supraorbital and supratrochlear nerves from V1, the infraorbital branches from V2, and the superficial temporal nerves from V3. A partial convergence of these two systems occurs at the Trigemino-Cervical Complex (TCC). In some embodiments, one or more stimulation elements 260 are positioned to stimulate the trigeminal and/or occipital nerves. One or more leads 265 can be anchored to the fascia proximate the tissue to be stimulated.

[242] To treat post-herpetic neuralgia (e.g. neuralgia associated with shingles), one or more stimulation elements 260 can be positioned to stimulate corresponding branches of the spinal nerves and/or peripheral nerves correlating to one or more dermatomes related to the patient's shingles.

[243] In some embodiments, apparatus 10 is configured to treat pelvic, bladder and/or bowel disorders, such as by stimulating sacral, pudendal and/or tibial nerves. In some embodiments, apparatus 10 is configured to treat pelvic pain by stimulating the tibial nerve.

[244] Apparatus 10 can be configured to treat a bladder, bowel or other dysfunction selected from the group consisting of: overactive bladder; urinary urgency; urinary frequency; urinary urgency frequency; urinary urge incontinence; urinary stress incontinence; urge incontinence; stress incontinence; non-obstructive urinary retention; female sexual dysfunction; fecal incontinence; accidental bowel leakage; constipation; diarrhea; irritable bowel syndrome; colitis; detrusor instability; detrusor dysfunction; spastic bladder; neurogenic bladder; detrusor sphincter dyssynergia; detrusor hyperreflexia; detrusor areflexia; and combinations of one or more of these.

[245] Apparatus 10 can be configured to treat a pelvic disorder selected from the group consisting of: pelvic pain; painful bladder syndrome; Hunner's ulcers or lesions; interstitial cystitis; pelvic floor dysfunction; endometriosis; vulvodynia; dyspareunia; pelvic adhesions; abdominal adhesions; irritable bowel syndrome; pelvic girdle pain; pudendal nerve entrapment; pudendal neuralgia; dysmenorrhea; Müllerian abnormalities; pelvic inflammatory disease; ovarian cysts; ovarian torsion; Loin pain hematuria syndrome; proctitis; prostatitis; prostatic pain; post-abdominal surgical pain; post-pelvic surgical pain; hernia pain; post-hernia surgical pain; anal pain; rectal pain; perineal pain; groin pain; vulvar pain; vaginal pain; clitoral pain; colitis; and combinations of one or more of these.

[246] Apparatus 10 can be configured to treat one or more of the pelvic disorders, bladder dysfunctions and/or and bowel dysfunctions listed above, by stimulating (e.g. using bilateral and/or unilateral stimulation) one or more of the targets listed below.

[247] In some embodiments, the stimulated targets include the sacral nerves (roots) S2, S3 and/or S4. One or more leads 265 (e.g. each including one or more stimulation-delivering stimulation elements 260) can be positioned to stimulate any or all of the three roots, on a single side or both sides, in any bilateral or unilateral combination. The roots can be accessed, with the patient lying in the prone position, by positioning one or more leads 265 (e.g. percutaneously), with or without the use of fluoroscopy, ultrasound or any other imaging modality, into one/any of the sacral foramen(a) from the posterior aspect of the sacrum. One or more leads 265 can be passed through the foramen to the anterior side of the sacrum, and/or one or more leads 265 can remain inside the foramen(a).

[248] In some embodiments, the sacral roots are approached rostrally, via the sacral canal in a retrograde manner. In these embodiments, one or more leads 265 can be passed through the

ligamentum flavum, just caudal to L5 or via any of the intervertebral spaces from L5 to T12, into the spinal canal. One or more leads 265 are then threaded, with or without the aid of visualization (fluoroscopy, ultrasound or other imaging modality), in a caudal (retrograde) manner to enter the sacral canal. One or more leads 265 can be placed along the sacral canal, and each root can be stimulated individually and/or each root can be stimulated in concert, via one or more leads 265 positioned along the internal surface of the sacral canal, and spanning one or more foramina.

[249] In some embodiments, one or more leads 265 are threaded from the spinal canal into each and/or all sacral foramen(a), in an anterior direction. The sacral canal can also be accessed caudally by one or more leads 265, via the sacral hiatus in an anterograde manner.

[250] In some embodiments, the sacral roots (S2, S3 and/or S4) are accessed as they enter the spinal cord at the cauda equina. This access can be achieved by inserting the one or more leads 265 through the ligamentum flavum, at a location just caudal to L5, or via any of the intervertebral spaces from L5 to T12, into the spinal canal. The one or more leads 265 can then be threaded, with or without the aid of visualization (fluoroscopy, ultrasound or other imaging modality), up to the cauda equina, where the S2, S3 and/or S4 roots can be stimulated where they enter the spinal cord, and/or the conus medullaris can be stimulated directly (e.g. in the same location).

[251] In some embodiments, the pudendal nerve is stimulated through one or more different approaches. The pudendal nerve contains both afferent and efferent fibers carried by S2, S3 and S4 roots. The pudendal fibers exit Alcock's canal near the ischial spine, where they spread out to innervate to the bladder wall, perineum, anus, genitals and urethra. Pelvic and voiding disorders can be treated by stimulating pudendal nerve fibers. The fibers can be accessed at the Alcock's canal via various approaches. In one embodiment, a transperineal approach is achieved by positioning the patient in the lithotomy position and inserting the lead 265 midpoint between the ischial tuberosity and the anus. A lead 265 is inserted toward the ischial spine, which can be palpated transvaginally or transrectally. The ischial spine can also be visualized through a number of imaging modalities (e.g. fluoroscopy, x-ray, ultrasound, and the like). In another embodiment, a transvaginal approach is achieved by positioning the patient in the lithotomy position and inserting a lead 265 through the vaginal wall, adjacent to the ischial spine (e.g. through the vaginal wall toward the ischial spine). In another embodiment, a posterior approach is achieved by laying the patient in the prone position and inserting a lead 265 just medial to the ischial tuberosity toward the ischial spine. This insertion can be facilitated by rectal palpation of

the ischial spine and through visualization via a number of imaging modalities (e.g. fluoroscopy, x-ray, ultrasound, and the like).

[252] In some embodiments, apparatus 10 is configured to stimulate pudendal afferents, such as by stimulating the dorsal genital nerve. These fibers are located just below the skin on the dorsum of the penis or just rostral to the clitoris. In some embodiments, pudendal afferents are stimulated periurethrally. One or more leads 265 can be inserted alongside the urethra to stimulate the pudendal fibers.

[253] In some embodiments, apparatus 10 is configured to stimulate tibial nerve fibers, such as to treat one or more pelvic disorders (e.g. voiding dysfunction). In order to provide stimulation of the tibial nerve, lead 265 can be inserted at a location close to the knee and/or at a location near the ankle. For example, the tibial nerve can be accessed a few mm below the skin surface in the ankle immediately posterior to the medial malleolus. Lead 265 can comprise a cylindrical SCS-type lead, which can be inserted percutaneously in this location. Alternatively or additionally, a direct (surgical) cut-down procedure can be used to insert a cylindrical lead or to apply a cuff electrode directly to the nerve. The tibial nerve can also be accessed approximately half way up the lower leg adjacent to the tibia. One or more leads 265 can be inserted percutaneously in this location. Alternatively or additionally, a direct cut-down can be used to insert lead 265 (e.g. a cylindrical lead or a cuff electrode and/or hemi-cuff electrode applied directly to the nerve in the mid-shin location). Tibial nerve fibers can be accessed in the popliteal fossa behind the knee, for example percutaneously with a lead 265 comprising a cylindrical lead, and/or via a direct cut-down, for example with a lead 265 comprising either a cylindrical or cuff electrode.

[254] In some embodiments, apparatus 10 and one or more leads 265 are constructed and arranged to stimulate the tibial and/or pudendal nerves via a transvascular approach (i.e. stimulation energy delivered from inside a blood vessel to nerve tissue proximate the blood vessel), such as via the femoral vein and/or artery, each of which provide intraluminal access to many other blood vessels (e.g. using standard interventional techniques). The tibial nerve can be transvascularly stimulated by the popliteal vein and/or artery (e.g. by placing one or more stimulation elements 260 in the popliteal vein and/or artery), at a location behind the knee. The popliteal vein and/or artery can be intraluminally accessed from the femoral artery and vein. The tibial nerve also passes near the small saphenous vein, where it branches off of the popliteal vein. The posterior tibial vein and/or artery are positioned adjacent to the tibial nerve, from the knee to the foot. One or more leads 265 can utilize one or more of these above locations to stimulate the tibial nerve.

[255] In some embodiments, apparatus 10 and one or more leads 265 are constructed and arranged to stimulate the pudendal nerve and/or sacral roots, such as using a lead 265 placed via the femoral vein and/or artery, which in turn provides intraluminal access to many vessels. One or more leads 265 can be configured to utilize any of the following arteries and veins to stimulate the pudendal nerve and/or the sacral roots. One or more leads 265 can be constructed and arranged to stimulate a target site via a blood vessel selected from the group consisting of: the internal pudendal artery or vein (which branch off of common iliac artery or vein, respectively); the inferior and superior gluteal vein and/or artery; middle rectal, pudendal plexus and internal iliac vein and/or artery; medial and lateral sacral vein and/or artery; uterine and obturator vein and/or artery; and combinations of one or more of these.

[256] In some embodiments, apparatus 10 is configured to treat pelvic dysfunction, overactive bladder, and/or urinary incontinence (singly or collectively “overactive bladder” herein). In some embodiments, apparatus 10 is configured to treat overactive bladder such as to reduce the effects of overactive bladder and/or to decrease use of one or more medications taken by the patient to treat overactive bladder. In some embodiments, one or more stimulation elements 260 are positioned to stimulate tissue of the central nervous system or tissue and/or tissue of the peripheral nervous system to treat overactive bladder, such as to stimulate one or more nerves that control and/or are otherwise related to bladder function (e.g. to increase bladder capacity, improve bladder emptying, reduce urge incontinence and/or reduce stress incontinence). For example, one or more stimulation elements 260 are positioned to stimulate tibial nerve tissue and/or sacral nerve tissue (e.g. at least the S3 nerve root) to treat overactive bladder. In some embodiments, one or more stimulation elements 260 can be positioned to stimulate sacral nerve tissue to treat urinary urgency, urinary frequency (e.g. urinary urgency frequency), and/or painful bladder syndrome. In some embodiments, lead 265 is constructed and arranged to be positioned along one or more locations of the tibial nerve, such as a positioning performed using percutaneous technique (e.g. when lead 265 comprises a cylindrical SCS-type lead) and/or surgical (cut-down) techniques (e.g. when lead 265 comprise a cuff electrode and/or hemi-cuff electrode applied directly to the nerve). The tibial nerve branches off of the sciatic nerve just above the knee, and runs along the length of the tibia, medial and lateral to the tibia. The tibial nerve then passes posterior to the medial malleolus prior to innervating the plantar surface of the foot. Lead 265 can be constructed and arranged to access sites proximate the tibial nerve percutaneously and/or through an incision at the back of the knee in the popliteal fossa, along the tibia or behind the medial malleolus. The housing 210 can be placed anywhere in the leg when stimulating the tibial nerve. Lead 265 can be constructed and arranged to stimulate the

tibial nerve through a transvascular approach, via the femoral vein and/or artery, each of which provide intraluminal access to many vessels. The tibial nerve can be accessed by the popliteal artery and vein behind the knee, which are intraluminally accessible from the femoral artery and vein, respectively. The tibial nerve also passes near the small saphenous vein, where it branches off of the popliteal vein. The posterior tibial vein and artery travel adjacent to the tibial nerve from the knee to the foot. One or more leads 265 can be constructed and arranged to utilize any of these locations to transvascularly stimulate the tibial nerve (e.g. transvascularly stimulate the tibial nerve via the popliteal artery, popliteal vein, saphenous vein, posterior tibial artery and/or posterior tibial vein via a lead 265 advanced via the femoral vein and/or artery). In these transvascular embodiments, the housing 210 can be placed near the femoral or popliteal access point at locations in the groin, perineum, scrotum, pelvis, hip, thigh, leg, behind the knee, buttocks, abdomen and/or low back. In the case of sacral nerve stimulation, one or more leads 265 can be inserted through an incision(s) made in the lower back, such that one or more stimulation elements 260 are positioned proximate (e.g. in contact) with the sacral nerve root(s). The housing 210 can be placed anywhere in the groin, perineum, scrotum, pelvis, hip, thigh, leg, behind the knee, buttocks, abdomen and/or low back. Lead 265 (e.g. a lead 265 comprising a lead extension) can be extended underneath the skin (e.g. tunneled) to a second incision (e.g. across the flank to the lower abdomen, across the midline to the buttocks, or low back), and a third incision can be made (e.g. in the abdomen, back or buttocks) where housing 210 can be inserted and connected to lead 265. Alternatively, housing 210 can be inserted at another internal location. If lead 265 is already connected (e.g. attached in manufacturing) to housing 210, lead 265 can be advanced in the opposite direction, such as from the third incision, to the second incision, to the first incision (if three incisions are made), or housing 210 can be advanced under the tissue from incision 1 to incision 2 or from incision 2 to incision 3. In some embodiments, only 1 or 2 incisions are performed. In some embodiments, such as when lead 265 is already connected (e.g. attached in manufacturing) to housing 210, lead 265 and housing 210 are implanted. In some embodiments, a first lead 265 and a first housing 210 (pre-attached or attachable) are utilized in a dose titration or other “trialing procedure”, and a second lead 265 and housing 210 (pre-attached or attachable) are implanted in the patient for subsequent treatment of the patient.

[257] In some embodiments, one or more stimulation elements 260 are positioned to perform posterior tibial nerve stimulation (PTNS), such as to perform an indirect form of neuromodulation to treat bladder voiding dysfunction. The posterior tibial nerve is derived from the lumbar-sacral nerves (L4-S3), which innervate the bladder detrusor and pelvic floor. In some

embodiments, one or more stimulation elements 260 are positioned to perform retrograde stimulation of the sacral nerve plexus and restore the balance between bladder inhibitory and excitatory control systems of the bladder. One or more stimulation elements 260 can be positioned above the ankle, proximate and/or into the tibial nerve. Implantable device 200 can deliver stimulation energy to the stimulation elements 260 comprising low-voltage electrical stimulation configured to produce sensor and/or motor responses. Apparatus 10 can be configured to provide continuous and/or intermittent stimulation to tissue, such as to modulate transmission of excitatory nerve signals to the bladder muscles. In some embodiments, implantable system 20 is configured to deliver a series of repeated stimulation periods, such as a regimen of approximately: weekly thirty-minute sessions of stimulation for twelve weeks. In some embodiments, implantable system 20 is configured to provide weekly, daily and/or hourly sessions that deliver stimulation for between 10 minutes and 60 minutes. Implantable system 20 can deliver stimulation for any number of minutes per day. In some embodiments, apparatus 10 is configured to achieve an approximate 50% reduction in urinary urge incontinence and/or urinary urgency/frequency episodes.

[258] In some embodiments, apparatus 10 is configured to provide temporary stimulation of tissue to treat overactive bladder, such as by using trialing interface 80 and/or 90 described hereabove, such as to provide power and/or data to one or more implantable devices 200 to confirm acceptable improvement of the patient's overactive bladder (e.g. successful stimulation of one or more sacral nerves, tibial nerves or other tissue), before closing an incision or otherwise fully implanting one or more implantable devices 200. In some embodiments, a temporary stimulation (for overactive bladder or in a trialing procedure for any therapy) is provided for up to one week, up to one month, more than 1 month, more than 2 months, or more than 3 months. In some embodiments, one or more implantable devices 200 are left in place if the temporary stimulation period is successful or unsuccessful (e.g. left implanted due to its small size or otherwise minimal impact on the patient).

[259] In some embodiments, apparatus 10 is configured to stimulate a region of the pelvic floor, such as to: change the reflex thresholds of the bladder muscles responsible for bladder emptying, strengthen and/or otherwise improve the condition of the muscles that maintain closure on the bladder outlet; change the state of the neural pathways, musculature and/or bladder during and beyond the period stimulation; and/or otherwise decrease the severity of urinary incontinence. In some embodiments, one or more stimulation elements 260 are positioned to stimulate periurethral muscles. In some embodiments, one or more stimulation elements 260 are positioned to stimulate tissue of the vagina or anus. In some embodiments, one

or more stimulation elements 260 are positioned to stimulate sphincter muscles for controlling the bladder, such as two stimulation elements 260 positioned on either side of the urethral orifice. In these embodiments, housing 210 can be implanted in suprapubic region or in the perineum. In some embodiments, lead 265 comprises (e.g. on a distal portion) a pessary ring comprising two stimulation elements 260. In some embodiments, stimulation elements 260 comprise periurethral electrodes configured to stimulate pudendal afferents.

[260] As described above, apparatus 10 can be configured for treating numerous diseases, disorders or other undesirable patient conditions, such as fecal incontinence. Injury of nerves that sense stool in the rectum can lead to fecal incontinence. In some embodiments, one or more stimulation elements 260 (e.g. one or more electrical, magnetic, light or other energy delivery elements) of one or more leads 265 and/or one or more implantable devices 200 are configured to stimulate tissue to treat fecal incontinence, such as to treat tissue selected from the group consisting of: sacral nerve tissue; tissue whose stimulation strengthens muscles of the bowel and/or rectum; and combinations of one or more of these. In these fecal incontinence applications, leads 265 can be implanted in a location selected from the group consisting of: the pelvic girdle; the sacral foramina; the lower back; the upper buttock; and combinations of one or more of these, such as to stimulate sacral nerve tissue. Leads 265 can be anchored via lead anchors (silicone or other materials), suture, staples, clips, adhesive and the like, such as an attachment to the underlying fascia of target tissue to be stimulated. In some embodiments, apparatus 10 is configured to treat both fecal incontinence and a bladder disorder such as overactive bladder, such as when one or more stimulation elements 260 are configured to deliver energy to sacral nerve or other tissue.

[261] In some embodiments, apparatus 10 is configured to treat fecal incontinence, overactive bladder (i.e. overactive bladder and/or urinary incontinence), and/or pelvic disorders, and implantable device 200: comprises between 1 and 16 stimulation elements 260, such as four or more electrodes; delivers electrical stimulation energy at a range of approximately between 10Hz and 15Hz (or a range of between 5Hz and 25Hz); delivers electrical stimulation energy with a pulse width of approximately between 180 μ sec and 240 μ sec (or between 1 μ sec and 200 μ sec); provides electrical stimulation energy with an amplitude of approximately 0.1V to 8.5V (e.g. providing a current between 0.1mA to 10mA, which can be adjusted in increments between 0.01mA and 0.1mA), such as an amplitude between 0.4V and 2.0V; delivers continuous electrical stimulation energy; delivers intermittent electrical stimulation energy, such as with a period between 8 seconds and 24 seconds and/or an on time between 8 seconds and 16 seconds; or an on time of several hours followed by an off time of several hours (such as 8 hours of

stimulation ON and 16 hours of stimulation OFF or 16 hours on and 8 hours off, and 12 hour on and 12 hours off; delivers monopolar electrical energy; delivers bipolar electrical energy; and combinations of one or more of these.

[262] In some embodiments, apparatus 10 is configured to treat an occipital neuralgia, such as migraine headache, headache and/or cluster headache, and one or more stimulation elements 260 (e.g. small column paddle electrodes, standard paddle electrodes or other electrodes) are positioned to stimulate nerve tissue selected from the group consisting of: occipital; supraorbital; infraorbital; greater occipital nerve (GON); lesser occipital nerve (LON); both supraorbital and GON; supratroclear; sphenopalantine (SPG); and combinations of one or more of these.

[263] In some embodiments, apparatus 10 is configured to treat neuralgia, such as a neuralgia resulting from surgery (e.g. groin, shoulder, lung and/or amputation), trauma and/or phantom pain, and one or more stimulation elements 260 are positioned to stimulate nerve tissue.

[264] In some embodiments, apparatus 10 is configured to treat neuralgia, such as a neuralgia resulting from groin surgery (e.g. hernia or other groin surgery), and one or more stimulation elements 260 are positioned to stimulate nerve tissue selected from the group consisting of: ilioinguinal; genitofemoral; iliohypogastric; and combinations of one or more of these.

[265] In some embodiments, apparatus 10 is configured to treat neuralgia, such as a neuralgia resulting from shoulder surgery, and one or more stimulation elements 260 are positioned to stimulate axial nerve tissue (e.g. one or more stimulation elements 260 positioned on a lead 265 implanted in a suprascapular location).

[266] In some embodiments, apparatus 10 is configured to treat neuralgia, such as a neuralgia resulting from lung surgery, and one or more stimulation elements 260 are positioned to stimulate intercostal nerve tissue.

[267] In some embodiments, apparatus 10 is configured to treat neuralgia, such as a neuralgia associated with carpal tunnel syndrome, and one or more stimulation elements 260 are positioned to stimulate median nerve tissue.

[268] In some embodiments, apparatus 10 is configured to treat neuralgia, such as a neuralgia associated with temporomandibular joint disorder (TMJ), and one or more stimulation elements 260 are positioned to stimulate V2 of trigeminal nerve tissue.

[269] In some embodiments, apparatus 10 is configured to treat neuralgia, such as a facial neuralgia, and one or more stimulation elements 260 are positioned to stimulate trigeminal nerve tissue.

[270] In some embodiments, apparatus 10 is configured to treat neuralgia, such as a leg (sciatic) neuralgia, and one or more stimulation elements 260 are positioned to stimulate nerve tissue proximal a contributing lesion.

[271] In some embodiments, apparatus 10 is configured to treat pelvic pain, such as interstitial cystitis and/or bladder pain, and one or more stimulation elements 260 are positioned to stimulate peripheral nervous system tissue (e.g. pudendal tissue and/or S-2, S-3 and/or S-4 roots) and/or central nervous system tissue (e.g. lower spinal cord and/or S3 neural foramen).

[272] In some embodiments, apparatus 10 is configured to treat pelvic pain, such as anal pain, and one or more stimulation elements 260 are positioned to stimulate peripheral nerve tissue such as pudendal tissue and/or S-2, S-3 and/or S-4 roots.

[273] In some embodiments, apparatus 10 is configured to treat subcutaneous pain, and one or more stimulation elements 260 (e.g. paddle electrodes) are positioned to stimulate nerve tissue.

[274] In some embodiments, apparatus 10 is configured to treat diabetic neuropathy, such as painful diabetic neuropathy, and one or more stimulation elements 260 are positioned proximate the lower spinal cord (e.g. to stimulate S3 nerves) or other body location to stimulate nerve tissue.

[275] In some embodiments, apparatus 10 is configured to treat visceral pain, angina and/or other pain, and one or more stimulation elements 260 are positioned to stimulate the vagus nerve.

[276] In some embodiments, apparatus 10 is configured to treat peripheral vascular disease, diabetic neuropathy and/or other conditions associated with diabetes, such as to treat a disease or disorder selected from the group consisting of: peripheral diabetic neuropathic pain; painful diabetic peripheral neuropathy; peripheral vascular disease; peripheral arterial disease; peripheral artery disease; cardiac autonomic neuropathy; diabetic autonomic neuropathy; diabetic sensory neuropathy; diabetic motor neuropathy; diabetic sensorimotor neuropathy; diabetic muscular atrophy; diabetic neurovascular disease; and combinations of one or more of these. In these embodiments, lead 265 can be positioned proximate a nerve in the foot, leg, arm and/or sacrum (e.g. such that one or more stimulation elements 260 are positioned proximate the nerve to be stimulated). In some embodiments, lead 265 is positioned to stimulate the dorsal root ganglia to treat diabetic neuropathy (e.g. diabetic neuropathy of the hand and/or foot). Lead 265 can be implanted percutaneously and/or surgically as described herein. Lead 265 and/or one or more stimulation elements 260 can comprise a paddle electrode, such as one or more paddle electrodes implanted in the foot, leg and/or arm. Lead 265 and/or one or more stimulation elements 260 can comprise a cuff or hemi-cuff electrode surgically implanted around a nerve in the foot, leg

and/or arm. Apparatus 10 can be configured to provide spinal cord stimulation, either through percutaneous insertion of one or more leads 265 in the epidural space or surgical implantation of a lead 265 comprising a paddle lead positioned in the epidural space. Apparatus 10 can be configured to provide transvascular stimulation of nerves in the foot, leg and/or arm, (e.g. to treat diabetic neuropathy) such as when one or more leads 265 are interventionally advanced into the venous or arterial system. Leads 265 can be positioned using percutaneous transforaminal placement in the sacral foramina, such as for treatment of foot or leg disorders. Leads 265 can be constructed and arranged for cephalocaudal insertion (retrograde) into the epidural space or sacral canal, such as for treatment of foot or leg disorders. Leads 265 can be constructed and arranged to provide dorsal root ganglion stimulation, such as for treatment of trunk, neck, head, back, foot, leg, arm and/or hand disorders.

[277] One or more leads 265 (e.g. each including one or more stimulation elements 260) can be constructed and arranged to stimulate tibial nerve fibers, such as to treat diabetic neuropathy and/or diabetic related maladies of the foot. The tibial nerve can be accessed as described herein.

[278] One or more leads 265 can be configured to stimulate the peroneal nerve or saphenous nerve, such as at one or more locations described herebelow. The peroneal nerve can be accessed percutaneously or surgically behind the knee in the popliteal fossa where it branches off the sciatic nerve. It can also be accessed as it wraps around the lateral aspect of the knee just prior to diving under the fibularis longus and extensor digitorum longus muscles. The deep fibular nerve (a branch of the peroneal nerve) innervates top medial foot, whereas the superficial fibular (peroneal) innervates top of both medial and lateral foot. In some embodiments, stimulation element 260 comprises one or more electrodes positioned in the anterior tibial vein and/or artery to transvascularly stimulate the deep fibular nerve. The saphenous nerve comes off the femoral nerve deep in the thigh. It passes around the medial aspect of the knee medial to the patella. It then runs down the medial shin adjacent to the tibia, gastrocnemius and soleus muscles where it can be accessed surgically or percutaneously. It then surfaces just as it warps around the anterior aspect of the medial malleolus where it supplies the medial posterior foot in front of heel. The medial sural cutaneous nerve comes off the tibial at the popliteal fossa, then runs down the back of the calf (over the gastrocnemius) and wraps around the posterior aspect of the lateral malleolus before innervating the lateral aspect of the sole and heel. In some embodiments, the saphenous nerve is transvascularly stimulated by positioning one or more stimulation elements 260 in a blood vessel selected from the group consisting of: femoral vein; femoral artery; great saphenous vein; great saphenous artery; and combinations of one or more of

these. In some embodiments, the sural nerve is stimulated. In these embodiments, the sural nerve can be transvascularly stimulated by positioning one or more stimulation elements 260 in the saphenous vein.

[279] One or more leads 265 can be configured to stimulate the median nerve, ulnar nerve and/or radial nerve. The median nerve can be accessed percutaneously in the upper arm lateral to the brachial vein and/or artery, but medial to the biceps muscle, whereas the ulnar nerve runs medial to the brachial artery in the upper arm. The median nerve passes through the anterior aspect of the elbow under the bicipital aponeurosis. The ulnar nerve runs medial and posterior to the medial epicondyle of the humerus. The median nerve can also be accessed in the wrist just proximal to the palm and the palmar carpal ligament. The ulnar nerve can be accessed just proximal to the palmar carpal ligament adjacent to the pisiform. The radial nerve can be accessed percutaneously just as it passes anterior to the lateral epicondyle. In some embodiments, apparatus 10 is configured to transvascularly stimulate at least one of a median nerve, an ulnar nerve or a radial nerve, and stimulation element 260 comprises one or more electrodes positioned in a vessel selected from the group consisting of: brachial vein; brachial artery; basilic vein; basilic artery; deep vein of the arm; deep artery of the arm; and combinations of one or more of these. In some embodiments, apparatus 10 is configured to transvascularly stimulate at least one of a median nerve or an ulnar nerve, and stimulation element 260 can comprise one or more electrodes positioned in a vessel selected from the group consisting of: brachial vein; brachial artery; and combinations of one or more of these. In some embodiments, apparatus 10 is configured to transvascularly stimulate the radial nerve, and stimulation element 260 comprises one or more electrodes positioned in a vessel selected from the group consisting of: deep vein of arm; deep artery of arm; basilic vein; radial collateral vein; radial collateral artery; medial collateral vein; medial collateral artery; radial vein; radial artery; and combinations of one or more of these. In some embodiments, apparatus 10 can be configured to transvascularly stimulate the medial cutaneous nerve, and stimulation element 260 comprises one or more electrodes positioned in the basilic vein. In some embodiments, apparatus 10 is configured to transvascularly stimulate the ulnar nerve, and stimulation element 260 comprises one or more electrodes positioned in a vessel selected from the group consisting of: ulnar collateral vein; ulnar collateral artery; ulnar vein; ulnar artery; and combinations of one or more of these. In some embodiments, apparatus 10 is configured to transvascularly stimulate the median nerve, and stimulation element 260 can comprise one or more electrodes positioned in a vessel selected from the group consisting of: brachial vein; brachial artery; ulnar vein; ulnar artery; and combinations of one or more of these.

[280] As described herein, one or more leads 265 can be positioned to stimulate the spinal cord, such as via percutaneous insertion of a lead 265 in the epidural space or surgical implantation of the lead 265 (e.g. a paddle lead) in the epidural space. A lead 265 can be placed such that one or more stimulation elements 260 (e.g. one or more electrodes) are positioned from T5-S5, such as to capture the area of pain or reduced circulation of the leg or foot. One or more stimulation elements 260 of one or more leads 265 can be positioned from C2 to T8, such as to capture the area of pain or reduced circulation of the arm or hand. One or more leads 265 can be placed along the midline, unilaterally and/or bilaterally over the dorsal columns, in the gutter (over dorsal roots) and/or in the dorsal root entry zone. Leads 265 can span several vertebral levels or they can be positioned to span a single level.

[281] One or more stimulation elements 260 (e.g. one or more electrodes attached to one or more leads 265) can be positioned to transvascularly stimulate one or more nerves, such as one or more nerves in the foot, leg and/or arm, such as when the one or more stimulation elements 260 are implanted within one or more blood vessels of the venous and/or arterial system.

[282] In the leg, the tibial nerve, sacral roots and/or deep fibular nerve can be stimulated, such as when a lead 265 accesses the tissue to be stimulated through a transvascular approach, such as via the femoral vein and/or artery, as described herein. The deep fibular nerve can be stimulated by one or more stimulation elements 260 positioned in the anterior tibial vein and/or the anterior tibial artery. In the arm, the median nerve, ulnar nerve, superior ulnar nerve, medial cutaneous nerve and/or radial nerve can be stimulated, such as when lead 265 accesses the tissue to be stimulated through a transvascular approach, such as via the brachial vein and/or artery, the basilic vein and/or artery, and/or the deep vein and/or artery.

[283] One or more stimulation elements 260 (e.g. one or more electrodes attached to one or more leads 265) can be positioned to stimulate dorsal root ganglia that supply the following nerves (e.g. to treat the leg and/or foot): common peroneal (L4-S2); tibial (L4-S3); femoral (L2-L4); and combinations of one or more of these. One or more stimulation elements 260 (e.g. one or more electrodes attached to one or more leads 265) can be positioned to stimulate dorsal root ganglia that supply the following nerves (e.g. to treat the hand and/or arm): radial (C5-T1); median (C5-T1); ulnar (C7-T1); and combinations of one or more of these. In these embodiments, one or more leads 265 can be passed through the intervertebral foramina, either unilaterally or bilaterally, at a single vertebral level or at multiple vertebral levels.

[284] In some embodiments, apparatus 10 is configured to treat post-amputation pain, such as to treat a disease or disorder selected from the group consisting of: phantom limb pain; phantom stump pain; acute and persistent stump pain; limb pain; neuroma; Morton's neuroma;

neurilemoma; neurolemoma; Schwann cell tumor; phantom limb itch; phantom limb sensations; and combinations of one or more of these. Apparatus 10 can be configured to treat the conditions associated with post-amputation pain (i.e., stump pain), such as by using a high frequency alternating current (HFAC) block approaches. In these embodiments, one or more leads 265 can be implanted such that one or more stimulation elements 260 stimulate one or more nerves in the leg, arm and/or sacrum. One or more leads 265 can be surgically implanted, such as when lead 265 comprises a paddle electrode positioned near a nerve in the foot, leg or arm and/or a cuff electrode or hemi-cuff electrode positioned to at least partially surround a nerve in the foot, leg or arm. One or more leads 265 can be positioned to stimulate the spinal cord, such as via a percutaneous insertion of the leads 265 in the epidural space or surgical implantation of the lead 265 (e.g. a paddle lead) in the epidural space. One or more leads 265 can be positioned to provide transvascular stimulation of nerves in the leg or arm, such as when one or more stimulation elements 260 are implanted within a vein or artery. One or more leads 265 can be implanted using percutaneous transforaminal placement in the sacral foramina, such as for treatment of leg stump pain. One or more leads 265 can be implanted using cephalocaudal insertion (retrograde) into the epidural space or sacral canal, such as for treatment of leg stump pain. One or more leads 265 can be positioned to perform dorsal root ganglion stimulation and/or block, such as for treatment of leg and/or arm stump pain.

[285] In some embodiments, apparatus 10 is configured to treat occipital and/or headache (HA) pain, such as when apparatus 10 is configured to treat a disease or disorder selected from the group consisting of: occipital neuralgia; cervicogenic headache; tension headache; chronic and episodic migraine headache; tension headache; hemicrania continua; trigeminal autonomic cephalalgias (TACs); chronic and episodic cluster headache; chronic and episodic paroxysmal hemicranias; short-lasting unilateral neuralgiform headache attacks with conjunctival injection and tearing (SUNCT); short-lasting unilateral neuralgiform headache attacks with cranial autonomic symptoms (SUNA); long-lasting autonomic symptoms with hemicrania (LASH); post-traumatic headache; and combinations of one or more of these.

[286] Apparatus 10 can be configured to treat the conditions associated with headache pain and/or occipital neuralgia by stimulating one or more nerves in the head, such as one or more nerves selected from the group consisting of: greater and/or lesser occipital nerve (e.g. which arise from C2 and C3); the greater and/or lesser auricular nerves (e.g. which also arise from C2/C3); the third (least) occipital nerve (e.g. which arises from C3); and combinations of one or more of these. The infraorbital or supraorbital nerves can be access subcutaneously below and above the eye, respectively. Apparatus 10 can be configured to stimulate auriculotemporal,

supratrochlear and/or sub-occipital nerves. To stimulate any of these nerves, lead 265 (e.g. a cylindrical SCS-type lead) can be inserted percutaneously either subcutaneously or under the muscle. Alternatively, surgery (e.g. direct cut-down) can be performed to insert lead 265 (e.g. a cylindrical lead, a paddle lead, a cuff or hemi-cuff electrode) proximate, one and/or around these nerves. Alternatively or additionally, the nerves can be accessed transvascularily as described herein (e.g. when one or more stimulation elements 260 are implanted in a blood vessel).

Housing 210 can be implanted anywhere in the head under the skin, including: behind the ear, back of the head, the neck, in the face, and the like, where one or more external devices 500 can be positioned in, on and/or within a hat, headband, glasses, goggles, earpiece, necklace, patch, and the like. Apparatus 10 can be configured to treat headache pain and/or occipital neuralgia by stimulating tissue in the cervical spinal cord (C2-C3), for example proximate the location the nerve enters the cord from the foramen. One or more leads 265 can be placed over the dorsal columns, in the gutter, over the dorsal root entry zone and/or out in the foramen at the dorsal root ganglion. In some embodiments, the trigeminal and pterygopalatine ganglia are accessed by inserting one or more leads 265 through the face or the roof of the mouth. In these embodiments, housing 210 can be placed anywhere in the head under the skin, as described herein.

[287] In some embodiments, apparatus 10 is configured to treat post-herpetic neuralgia, such as to treat a disease or disorder selected from the group consisting of: shingles; herpes zoster; zoster; zona; varicella zoster virus infection; zoster sine herpette; fever blisters; herpes zoster blisters; herpes zoster rash; and combinations of one or more of these. In some embodiments, apparatus 10 is configured to treat post-herpetic neuralgia using high frequency alternating current (HFAC) block approaches. In these embodiments, one or more leads 265 can be implanted such that one or more stimulation elements 260 stimulate one or more nerves in the leg, arm, torso and/or sacrum. One or more leads 265 can be surgically implanted, such as when lead 265 comprises a paddle electrode positioned near a nerve in the foot, leg, torso and/or arm and/or a cuff electrode or hemi-cuff electrode positioned to at least partially surround a nerve in the foot, leg, torso or arm. One or more leads 265 can be positioned to stimulate the spinal cord, such as via a percutaneous insertion of the leads 265 in the epidural space or surgical implantation of the lead 265 (e.g. a paddle lead) in the epidural space. One or more leads 265 can be positioned to provide transvascular stimulation of nerves in the leg, torso and/or arm, such as when one or more stimulation elements 260 are implanted within a vein or artery. One or more leads 265 can be implanted using percutaneous transforaminal placement in the sacral foramina, such as for treatment of leg or foot pain. One or more leads 265 can be implanted using cephalocaudal insertion (retrograde) into the epidural space or sacral canal, such as for

treatment of leg or foot pain. One or more leads 265 can be positioned to perform dorsal root ganglion stimulation and/or block, such as for treatment of leg, torso and/or arm pain.

[288] In some embodiments, apparatus 10 is configured to treat angina, such as to treat a disease or disorder selected from the group consisting of: angina; chest pain caused by reduced blood flow to the heart muscle; chest pain associated with coronary artery disease such as squeezing, pressure, heaviness, tightness or pain in the chest; recurring angina pectoris; acute angina pectoris; chronic angina pectoris; acute coronary syndrome; chest pain; coronary artery spasms; microvascular angina; Prinzmetal's angina; angina inversa; stable or common angina; unstable angina; variant angina; and combinations of one or more of these.

[289] In some embodiments, apparatus 10 is configured to treat carpal tunnel syndrome, such as to treat a disease or disorder selected from the group consisting of: median nerve entrapment; tingling and/or numbness in fingers or hand; median nerve irritation or compression; narrowing of the carpal tunnel; and combinations of one or more of these. In these embodiments, apparatus 10 can be configured to deliver stimulation to median nerve tissue; ulnar nerve tissue and/or radial nerve tissue.

[290] In some embodiments, apparatus 10 is configured to treat erectile dysfunction (ED), such as to treat a disease or disorder selected from the group consisting of: impotence; male sexual dysfunction; inability to develop or maintain an erect penis; cardiogenic ED; vasculogenic ED; diabetic ED; neurogenic ED; traumatic ED; post-prostatectomy ED; hormonal ED; hypogonadism; pharmacological ED; and combinations of one or more of these.

[291] In some embodiments, apparatus 10 is configured to treat complex regional pain syndrome (CRPS), such as to treat a disease or disorder selected from the group consisting of: CRPS type 1; CRPS type 2; reflex sympathetic dystrophy; causalgia; reflex neurovascular dystrophy; amplified musculoskeletal pain syndrome; systemic autonomic dysregulation; neurogenic edema; musculoskeletal pain; and combinations of one or more of these.

[292] In some embodiments, apparatus 10 is configured to treat knee pain. Knee pain from joint degeneration or joint replacement surgery can be treated via stimulation of the nerves innervating the knee and/or via stimulation of the tissue surrounding the knee (sometimes referred to as peripheral field stimulation). Apparatus 10 can comprise between one and eight leads 265 whose stimulation elements 260 are placed near and around the knee. In some embodiments, four leads 265 are placed, in locations medial, lateral, superior and inferior to the knee. The leads 265 can be placed subcutaneously for field stimulation, or they can be placed directly adjacent to specific nerve targets. Applicable nerve targets are as follows: medial knee can include medial femoral cutaneous and infrapatellar cutaneous branches of saphenous nerve;

lateral knee can include constant articular branches of common peroneal, lateral retinacular nerve; anterior knee can include lateral, medial, and anterior cutaneous femoral nerve, infrapatellar branch of saphenous nerve, medial and lateral retinacular nerve and articular branches of peroneal nerve; posterior knee can include obturator, posterior tibial and sciatic nerves. In addition, the following nerves can be stimulated via stimulation elements 260 to treat knee pain: nerves arising from the tibial nerve such as the superior, middle and inferior genicular nerves; nerves arising from the common peroneal such as the superior lateral, inferior lateral, and recurrent genicular nerves; and nerves arising from the obturator nerve such as the genicular branch of obturator; and nerves arising from the femoral nerve such as the saphenous nerve. Each of these targets can be stimulated transvascularly by one or more stimulation elements 260.

[293] In some embodiments, implantable device 200 has an internal battery or other power supply such that stimulation (e.g. stimulation energy and/or a stimulation agent) is delivered to one or more locations within a patient for an extended time period (e.g. at least 1 hour, at least 1 day, at least 1 month or at least 1 year), without receiving a power transmission (e.g. as described herein from an external device such as external device 500) during that time period. In some embodiments, at least a portion of a single pulse of energy (e.g. at least a single phase) is delivered by implantable device 200 using energy provided by an internal power supply 570 such as a battery or a capacitor. In these embodiments, data can be transmitted by one or more of an external device 500 and/or a programmer 600, such as to activate or modify stimulation being delivered, with or without also transmitting power.

[294] In some embodiments, implantable device 200 comprises one or more components configured to receive transmitted power (e.g. via an external device 500), receive transmitted data (e.g. via an external device 500 and/or programmer 600) and/or deliver stimulation (e.g. deliver stimulation energy and/or a stimulation agent).

[295] In some embodiments, one or more implantable devices 200 are configured to deliver stimulation energy (e.g. via one or more stimulation elements 260 comprising an electrode) with a stimulation waveform comprising one or more high frequency signals (e.g. a signal comprising one or more high frequency components). For example, one or more implantable devices 200 can deliver one or more stimulation waveforms comprising one or more signals above 600Hz, such as one or more signals above 1.0kHz, 1.2kHz, 5kHz, 10kHz or 25kHz.

[296] In these embodiments, the delivered stimulation waveform can be configured to be void of (i.e. not include) one or more lower frequency signals, such as by not including any signals at a frequency below 100Hz, below 500Hz, below 1000Hz, below 1200Hz or below 1500Hz.

[297] One or more implantable devices 200 can be configured to deliver stimulation energy with a stimulation waveform that varies over time. In some embodiments, one or more stimulation parameters of the stimulation waveform are randomly varied over time, such as by using a probability distribution as described in applicant's co-pending United States Patent Application Serial Number 16/104,829, titled "Apparatus with Enhanced Stimulation Waveforms", filed August 17, 2018 [Docket nos. 47476-708.301; NAL-014-US]. Each stimulation waveform can comprise one or more pulses, such as a group of pulses that are repeated at regular and/or irregular intervals. In some embodiments, a pulse can comprise delivery of electrical energy, such as electrical energy delivered in one or more phases (e.g. a pulse comprising at least a cathodic or anodic portion followed by passive capacitive recovery with an optional open circuit time between the first portion and recovery). In some embodiments, a group of pulses is delivered, each pulse comprising an anodic or cathodic portion that can include charge recovery after each pulse, such as charge recovery comprising active (opposite polarity pulse) recovery, and/or passive (capacitive) recovery. In some embodiments, there is no recovery between pulses, but instead active or passive recovery is included at the end of the set of the first (anodic or cathodic) portions. In some embodiments, single or groups of pulses are provided at time-varying modes of repetition (e.g. regular intervals for a period, then a period of irregular intervals) or at regular intervals with occasional (random) spurious pulses inserted (creating a single irregular event in an otherwise regular series). Non-limiting examples of waveform variations include: a variation in frequency (e.g. frequency of one or more signals of the waveform); variation of a signal amplitude; variation of interval time period (e.g. at time period between pulses or a time period between pulse trains); variation of a pulse width; multiple piecewise or continuous variations of one or more stimulation parameters in a single pulse (e.g. multi-step, multi-amplitude in one "super-pulse"); variation of pulse symmetry (e.g. via active drive, passive recovery and/or active-assisted passive recovery); variation of stimulation energy over a time window and/or overlapping time windows; variation of the power in the frequency spectrum of the stimulation waveform; and combinations of one or more of these. In some embodiments, apparatus 10 and/or implantable device 200 can be configured to vary a stimulation waveform "systematically" such as a variation performed temporally (e.g. on predetermined similar or dissimilar time intervals) and/or a variation performed based on a parameter, such as a measured parameter that can be based on a signal produced by a sensor of implantable device 200 or another component of apparatus 10. Alternatively or additionally, apparatus 10 and/or implantable device 200 can be configured to vary a stimulation waveform randomly. Random variation shall include discrete or continuous

variations that can be selected from a distribution, such as a probability distribution selected from the group consisting of: a uniform distribution; an arbitrary distribution; a gamma distribution; a normal distribution; a log-normal distribution; a Pareto distribution; a Gaussian distribution; a Poisson distribution; a Rayleigh distribution; a triangular distribution; a statistic distribution; and combinations of one or more of these. Random pulses or groups of pulses can be generated based on randomly varying one or more stimulation signal parameters. One or more stimulation parameters can be varied randomly through the use of one or more probability distributions, as described herebelow.

[298] In some embodiments, the amplitude of a signal delivered by one or more implantable devices 200 is adjusted to prevent discomfort to the patient (e.g. paresthesia or other undesired condition) from the stimulation signal. In some embodiments, the amplitude of the stimulation signal can be ramped (e.g. up and/or down), a single time or multiple times (e.g. continuously or intermittently). In some embodiments, a titration procedure is performed to “set” one or more stimulation parameters based on avoiding patient discomfort.

[299] In some embodiments, one or more implantable devices 200 are configured to deliver stimulation energy (e.g. via one or more stimulation elements 260 comprising an electrode) with a stimulation waveform comprising one or more waveform patterns. The stimulation waveforms delivered can be configured to treat various conditions of a patient. Each stimulation waveform can comprise a series of continuous pulses, intermittent pulses, and/or spurious pulses (e.g. occasional events in an otherwise continuous stream). Each pulse can comprise a pulse train that is repeatedly delivered by implantable device 200, the train comprising one or more cathodic pulses and/or one or more anodic pulses. In some embodiments, implantable device 200 delivers a multiphasic pulse comprising at least two cathodic pulses and/or anodic pulses, with or without any time between each pulse. For example, implantable device 200 can deliver a biphasic pulse comprising a cathodic pulse followed by an anodic pulse, a triphasic pulse comprising a cathodic pulse followed by an anodic pulse followed by a second cathodic pulse, or any series of two or more cathodic and/or anodic pulses. In some embodiments, delivered pulses are exponential in nature (e.g. comprise an exponential portion), such as dynamic return pulses that exceed a minimum current (e.g. at least 1mA, 10mA or 50mA) for a short duration (e.g. for approximately 1μsec), and then decay to lower current levels (e.g. a level of approximately 100nA), with a time constant on the order of 1μsec to 100μsec.

[300] The stimulation waveforms delivered by implantable device 200 can comprise one or more high frequencies. The stimulation waveform frequency or other stimulation parameter can be set and/or adjusted (hereinafter “adjusted”) to optimize therapeutic benefit to the patient and

minimize undesired effects (e.g. paresthesia or other patient discomfort). In some embodiments, a stimulation waveform is adjusted based on a signal produced by a sensor of apparatus 10 (e.g. a sensor of implantable device 200, such as a stimulation element 260 configured as a sensor or other sensor of implantable device 200 as described hereabove). Adjustment of a stimulation waveform parameter can be performed automatically by the implantable device 200 and/or via an external device 500 and/or programmer 600).

[301] In some embodiments, a pulse shape of a stimulation waveform can be varied, such as a pulse shape comprising: a sinusoidal geometry; a square geometry (e.g. a waveform comprising a square wave); a rectangular geometry; a triangular geometry; (e.g. symmetric or asymmetric); a trapezoidal geometry; a sawtooth geometry; a ramped geometry; an exponential geometry; a piece-wise step function geometry; a root-raised cosine geometry; and combinations of one or more of these.

[302] In some embodiments, a charge recovery phase (e.g. anodal phase) of a stimulation waveform is varied by implantable device 200.

[303] Inter-pulse gap, the time between one or more pulses (e.g. a biphasic or other multiphasic pulse that is repeated continuously), can be varied systematically and/or randomly by implantable device 200. In some embodiments, inter-pulse gap between one or more pulses comprises zero time (i.e. a first pulse is immediately followed by a similar or dissimilar second pulse). In some embodiments, inter-pulse gap is varied systematically, such as on a routine basis (i.e. temporally) and/or varied based on a signal produced by a sensor of apparatus 10. Alternatively or additionally, inter-pulse gap can be varied randomly, such as a random variation based on a distribution (e.g. a probability distribution with a pre-determined shape) as described herebelow.

[304] In some embodiments, implantable device 200 delivers a stimulation waveform comprising a series of frequency modulated (FM) pulses, such that the frequency of stimulation varies. Implantable device 200 can be configured to deliver a frequency modulated stimulation waveform comprising a carrier signal, at a carrier frequency, that is modulated continuously between a first frequency and a second frequency. For example, implantable device 200 can deliver a stimulation waveform that modulates between 2.0kHz and 3.0kHz every second (e.g. comprising a carrier signal at 2.5kHz that is modulated at 1Hz) with a modulation range (the excursion from the carrier signal) of +/-500Hz. In some embodiments, implantable device 200 can deliver a stimulation waveform that comprises: a carrier frequency between 1kHz and 50kHz, a modulation frequency between 0.1Hz and 10kHz and/or a modulation range between 1Hz and the carrier frequency.

[305] In some embodiments, implantable device 200 delivers a stimulation waveform comprising a series of amplitude modulated (AM) pulses, such that the amplitude of stimulation varies (e.g. varying the amplitude of the voltage and/or current of the stimulation signal). The amplitude of delivered current can be varied in a single amplitude modulated sweep, such as a sweep from 2mA to 3mA. In some embodiments, amplitude of a signal can be varied continuously, such as when current is varied between 2mA and 3mA every second (e.g. a signal comprising a modulation frequency of 1Hz). In these embodiments, the depth of modulation would be 33%, where depth of modulation is equal to $1 - \frac{\text{lower range}}{\text{upper range}}$. In some embodiments, amplitude of delivered current fluctuates between 1mA and 3mA (i.e. a depth of modulation of 66%), while in other embodiments, current fluctuates between 0mA and 10mA (e.g. a depth of modulation of 100%). In some embodiments, implantable device 200 is configured to deliver an amplitude modulated signal comprising: a carrier frequency between 1KHz and 50kHz; a modulation frequency between 0.1Hz and the carrier frequency and/or a depth of modulation between 0.1% and 100%.

[306] In some embodiments, implantable device 200 delivers a stimulation waveform comprising delivery of continuously balanced analog current waveforms, for example from a differential Howland current source. In these embodiments, there are not independent pulses, but rather there is true analog frequency and amplitude modulation. Periods of delivering stimulation (or presence of balanced differential analog stimulation) and periods of no stimulation (e.g. a quiescent period) can be included. In some embodiments, controller 250 comprises one or more reconfigurable stimulation blocks including one or more Howland or other current sources. The one or more current sources (e.g. two or more current sources) can each be attached to a stimulation element 260 (e.g. in a monopolar configuration when the current source is also connected to housing 210 or in a bipolar configuration when the current source is connected to a pair of stimulation elements 260). Alternatively, controller 250 can comprise one or more current sources that are attached to a matrix of switches that selectively connect the one or more current sources to multiple stimulation elements 260 (e.g. connect a single current source to 2, 4, 8, 12 or 16 electrodes). In some embodiments, controller 250 is configured such that a stimulation waveform signal provided to the current source passes through a capacitor (e.g. capacitor C1 shown), the capacitor providing DC balance.

[307] In some embodiments, implantable device 200 delivers a stimulation waveform comprising delivery of multiple trains of pulses that are delivered intermittently, a “burst stimulation” waveform as defined hereabove. For example, implantable device 200 can be configured to deliver a series or train of five pulses, each with a 1msec pulse width. The each of

the five pulses can be separated by an inter-pulse gap of 4msec, creating a train-on period of 16msec. These five pulses can be repeated every 25msec (the “inter-train period”). In some embodiments, implantable device 200 can be configured to deliver a burst stimulation waveform comprising a pulse width between 5μsec and 1msec. Implantable device 200 can deliver a train or burst stimulation waveform comprising pulses with constant pulse widths and/or varying pulse widths, such as when the pulse widths (and/or other stimulation parameters) are varied randomly and/or systematically. Implantable device 200 can deliver a train or burst stimulation waveform with a varied or constant pulse shape selected from the group consisting of: sinusoid; square, rectangle; triangle (symmetric or asymmetric); trapezoid; sawtooth; ramp (e.g. a linear ramp); exponential curve; piece-wise step function; and combinations of one or more of these. Implantable device 200 can deliver a train or burst stimulation waveform with an inter-pulse gap less than inter-train period. The inter-pulse gap can be relatively constant, and/or it can be varied, such as when implantable device 200 randomly varies the inter-pulse gap or varies the inter-pulse gap systematically. In some embodiments, the inter-pulse gap between any two pulses within a pulse train (or burst) can be varied between 0.1μsec and the inter-train period (or inter-burst period). Implantable device 200 can deliver a train stimulation waveform with an inter-pulse gap between 1μsec and 1 second. Implantable device 200 can deliver a burst stimulation waveform with an inter-train period between 1μsec and 1 second. Implantable device 200 can deliver a burst stimulation waveform with an inter-burst period between 20μsec and 24 hours. The inter-burst period can be relatively constant, and/or it can be varied, such as when implantable device 200 randomly varies the inter-burst period or varies the inter-burst period systematically. In some embodiments, inter-burst period is varied by the user, such as via a user using programmer 600. In these embodiments, user activation can be regulated with one or more safeguards or other limits such as those incorporated into patient-controlled analgesia devices. The inter-train period can be varied between 1μsec and 24 hours. Implantable device 200 can deliver a train or burst stimulation waveform with a train-on period (the time between the onset of a first pulse in a pulse train to the end of the last pulse in a pulse train) between 10μsec and 24 hours. The train-on and/or burst-on period can be relatively constant, and/or it can be varied, such as when implantable device 200 randomly varies the train-on and/or burst-on period or varies the train-on and/or burst-on period systematically. Implantable device 200 can deliver a train or burst stimulation waveform with a train or burst envelope selected from the group consisting of: cosine; cosine-squared; sine; square; rectangle; triangle (symmetric or asymmetric); trapezoid; sawtooth; ramp (e.g. linear ramp); and combinations of one or more of these. Implantable device 200 can deliver a train and/or burst stimulation waveform with a train

ramp duration or burst ramp duration between 1µsec to 10 minutes. Implantable device 200 can deliver a train and/or burst stimulation waveform with a depth of modulation between train and/or bursts of between 1% and 99%. For example, between some or all of the trains and/or bursts (burst-off or train-off periods), a signal may be present and may contain the same or different elements contained in the train-on and/or burst-on period. These burst-off or train-off periods may comprise a quiescent period. The amplitude of the signal contained in these quiescent periods can be from 0% to 99% of the signal amplitude during the train-on and/or burst-on period, such as a signal with an amplitude less than 50% of the signal amplitude during the train-on and/or burst-on period or another amplitude below a neuronal excitation threshold.

[308] In some embodiments, apparatus 10 is configured to deliver stimulation energy to dorsal root ganglion and/or spinal cord tissue to treat a condition such as pain. In these and other embodiments, apparatus 10 can be configured to provide a stimulation waveform comprising: a combination of low frequency stimulation (e.g. electrical energy comprising a low frequency signal) and burst stimulation; burst stimulation (e.g. burst stimulation alone); a combination of low frequency stimulation and high frequency stimulation; a combination of low frequency stimulation, high frequency stimulation and burst stimulation; and combinations of one or more of these. The stimulation energy provided by apparatus 10 can be delivered to tissue via one or more stimulation elements 260, such as two or more electrodes which deliver similar or dissimilar stimulation waveforms simultaneously and/or sequentially. Each of the stimulation waveforms can comprise one or more pulses comprising an entire phase or at least a portion of a phase at a superthreshold level. Alternatively or additionally, each of the stimulation waveforms can comprise one or more pulses comprising an entire phase or at least a portion of a phase at a subthreshold level.

[309] In some embodiments, apparatus 10 is configured to vary one or more stimulation parameters. The stimulation parameters can be varied to optimize (e.g. balance the benefits of) therapeutic benefit, system efficiency, stimulation efficiency, avoidance and/or reduction of paresthesia, and/or reduction of charge.

[310] Referring now to Fig. 2, a flow chart of a method for positioning external device 500 on the skin of the patient is illustrated, consistent with the present inventive concepts. Method 2000 of Fig. 2 includes multiple steps for placing, orienting (e.g. rotationally orienting), and/or otherwise positioning (“positioning” herein) external device 500 on or otherwise proximate (“on” or “proximate” herein) the skin of the patient to ensure proper transfer of data and/or power to one or more implantable devices 200 that are positioned under the skin of the patient

(e.g. ensure a proper communication link will be maintained). Method 2000 is described using the various components of apparatus 10 described herein.

[311] In STEP 2010, one or more implantable devices 200 are implanted in the patient at an implant location LOC1 (e.g. LOC1 is the location of one or more implantable antennas 240 of device 200), such as a location under the skin on the patient's back. After recovery from the implantation procedure, STEP 2020 is performed in which an external device 500 is positioned on the patient's skin proximate location LOC1, such as a location on the skin of the patient's back.

[312] In STEP 2030, apparatus 10 provides feedback regarding the quality of the positioning of external device 500. Quality of the external device 500 position (e.g. relative to implantable antenna 240) can be determined via analysis of test transmissions sent from external device 500 to implantable device 200. For example, external device 500 can send a power and/or data transmission, after which implantable device 200 sends feedback, such as a received signal strength indicator (RSSI), to external device 500 related to the quality of the transmissions (e.g. the "link"). In some embodiments, a "reference" RSSI can be used to compare a measured signal level to the RSSI reference to determine the quality of the link. The RSSI reference can comprise a reference that is: determined during a manufacturing process of apparatus 10; based on a characterization of a population of previously manufactured external devices 500 and implantable devices; determined over time, during patient use of apparatus 10 (e.g. "learned" during actual use of one or more external devices 500 transmitting power and/or data with one or more implantable devices 200); and/or determined during a calibration process performed during programming. There can be multiple distinct link quality levels output by the RSSI, such as via a numeric scale (e.g. 1 through 4). Positioning of external device 500 can be modified (e.g. moved) to increase the determined link quality. In some embodiments, link quality (e.g. due to the position of external device 500 relative to antennas 240) can be determined based on an assessment of the voltage generated by the power system of implantable device 200 (e.g. the voltage of rectifier 232), such as when information regarding this voltage is transmitted from implantable device 200 to external device 500.

[313] In some embodiments, transmission quality (link quality) can be determined by measuring power consumption of apparatus 10 (e.g. measuring the power consumption of external device 500), and external device 500 positioning can be optimized (e.g. moved) based on the power consumption measurement. For example, each external device 500 can include an energy measurement circuit (e.g. a current measurement circuit) that can be used to determine energy draw (e.g. current draw) of the device 500. By either calibrating at time of programming

and/or learning over time during use (e.g. delivery of therapy to the patient), apparatus 10 can be configured to assess link quality by measuring the energy used (e.g. current draw).

[314] In some embodiments, apparatus 10 assesses transmission quality by both measuring power consumption as well as using a reference RSSI, such as is described hereabove.

[315] Feedback information of this transmission quality can be provided (e.g. to the patient) by one or more user output components (e.g. an alphanumeric screen, a red light/green light, speaker or other audible device, and the like). Feedback information can comprise a simple “good/bad” assessment, or a more detailed (e.g. 3 or more level) assessment of external device 500 position quality (e.g. to assess better versus worse placement of external device 500). In some embodiments, feedback information related to quality of external device 500 placement is indicated by a changing graph (e.g. bar chart) and/or a changing quantity on a display; and/or a changing tone (from a speaker).

[316] In STEP 2040, the feedback information provided is assessed (e.g. by the patient), and if acceptable, the positioning procedure of Method 2000 can be ended. If not acceptable (or if better positioning is desired), STEP 2050 can be performed where external device 500 is repositioned on the patient’s skin, at a different location that is still proximate to location LOC1.

[317] STEPS 2030 thru 2050 can be repeated multiple times, such as to compare various positions of external device 500 and/or to optimize external device 500 placement.

[318] In some embodiments, external device 500 is positioned on the skin of the patient via patient attachment device 70 (e.g. a belt, strap, vest, and/or other attachment device), and positioning (in STEP 2020) and/or repositioning (in STEP 2050) is performed using patient attachment device 70.

[319] In some embodiments, apparatus 10 can be configured to provide guidance in repositioning of external device 500 (e.g. relative to an implanted implantable device 200), such as directional guidance (e.g. up, down, left, right, and the like). For example, the user could enter information about a first repositioning motion (e.g. directional information provided using programmer 600), and apparatus 10 can use that information to provide subsequent repositioning guidance (e.g. feedback received from the repositioning performed via Steps 2030-2040).

[320] **Referring now to Figs. 3A-D** various views of a patient attachment device 70 and an external device 500 are illustrated, consistent with the present inventive concepts. Fig. 3A is a perspective view of **patient attachment device 70a**. Fig. 3B is a side view of an external device 500 inserted into the patient attachment device 70a. Fig. 3C is a perspective view of the external device 500 inserted into the patient attachment device 70a. Fig. 3D is a side sectional view of the external device 500 inserted into the patient attachment device 70a.

[321] Patient attachment device 70a can be configured to removably attach to external device 500, such as to first position patient attachment device 70a on the patient's skin, and subsequently insert external device 500 into the skin-attached device 70a. After a time period (e.g. after a time period of stimulation and/or other use, such as when power supply 570 is relatively depleted, and/or pain has been sufficiently reduced), external device 500 can be removed from attachment device 70a and replaced with a second (e.g. fully charged) external device 500. This replacement procedure can be repeated numerous times.

[322] Patient attachment device 70a of Figs. 3A-D includes a housing, **housing 71**, that includes a **retaining portion 72** and an **opening 74**, as shown. Retaining portion 72 can be sized and arranged to frictionally engage a portion of each external device 500. Housing 71 can comprise a shape that approximates the shape of at least a portion of an external device 500. For example, a contour of housing 71 can approximate a contour of a mating surface of external device 500 (e.g. a surface of a portion of housing 510 of external device 500). Additionally or alternatively, the "footprint" of attachment device 70a (i.e. perimeter shape) can match and/or approximate the "footprint" of housing 510 of external device 500 (e.g. a circle as shown).

[323] Opening 74 can be positioned near the center of patient attachment device 70a, such as to aid the user in positioning patient attachment device 70a over implantable device 200. For example, the user can palpate the patient's skin through opening 74 to locate implantable device 200 beneath the tissue and position patient attachment device 70a accordingly. Patient attachment device 70a can include an attachment element comprising an adhesive patch, **adhesive 75** shown, which can be positioned on the bottom side of housing 71 (e.g. the side positioned proximate the patient's skin). Alternatively or additionally, patient attachment device 70a can include a strap, belt or other attachment element, such as is described hereabove in reference to patient attachment device 70 of Fig. 1. Adhesive 75 can comprise one or more openings, such as opening 76 shown. Opening 76 can be included to allow viewing of the patient's skin through opening 76 (e.g. during and/or after placement). Opening 76 can be included to limit the amount of skin covered by adhesive 75 and/or covered by housing 71.

[324] Patient attachment device 70a can be constructed and arranged such that device 70a can be positioned on the patient by the patient themselves, and the positioning can be done with a single hand (e.g. when the patient's other hand is used to perform a palpation procedure to locate implantable device 200 as described herein). Patient attachment device 70a can be attached to the patient in any orientation, since when an external device 500 is inserted into patient attachment device 70a, patient attachment device 70a applies retention forces that prevent dislodgement of external device 500 (e.g. prevent dislodgement due to gravity).

[325] In some embodiments, adhesive 75 is configured to be re-activated (e.g. via a washing, cleaning and/or other process) and/or be replaced (e.g. removed and reattached to housing 71). Alternatively or additionally, adhesive 75 can comprise multiple independent, removable layers of adhesive, which can be sequentially removed to reactivate adhesive 75. In these embodiments, patient attachment device 70a can be attached to the patient's skin (e.g. as described herein) for a first time period (e.g. a time period in which one, two, or more external devices 500 are inserted and/or removed). After the first time period, device 70a can be removed from the patient's skin, adhesive 75 reactivated and/or replaced, and device 70a again positioned on the patient's skin for a second time period (e.g. a time period in which one, two, or more external devices 500 are inserted and/or removed).

[326] When external device 500 is to be positioned on the patient's back (e.g. when an implantable device 200 is implanted under the skin of the patient's back), it can be difficult to position external device 500 to ensure proper power and data transmission with implantable device 200. Patient attachment device 70a is configured to simplify attachment of patient attachment device 70a as well as subsequent insertion and removal of each external device 500 into and out of, respectively, device 70a.

[327] In some embodiments, external device 500 includes a projection, projection 5101, that mates with opening 74 of device 70a. Housing 510 and projection 5101 of device 500, as well as housing 71 and retaining portion 72 of device 70a comprise materials of construction and a geometry such as to have external device 500 remain captured by (e.g. secure within) device 70a, even when external forces are imparted on either component (e.g. forces encountered during running and/or other reasonable physical activity). For example, if device 500 begins to disengage due to such a force, retention forces provided by the engagement of the mating portions of device 500 and device 70a tend to reposition device 500 back into the secure, captured position.

[328] External device 500 can be configured to be relatively water-tight, such as when external device 500 is constructed and arranged to resist ingress of water when submerged 1 meter deep in a tank of water for 30 minutes. For example, housing 510 can include one or more portions that are attached via adhesive, welding, and the like, such as to resist water ingress. In some embodiments, external device 500 includes one or more controls 581 (e.g. controls 581a, 581b, and 581c shown in Fig. 3C) that are positioned on the external surface of housing 510, and these controls may be constructed and arranged to be relatively water-tight, such as at the level described hereabove. In some embodiments, controls 581 comprise one or more controls that are manufactured using in-mold decorating (IMD) technology, where a flexible printed plastic film

applique is utilized with rigid substrate insert molding. Control 581 can comprise one or more switches or other controls comprising an engagement surface (e.g. a membrane that is pressed by a finger of the patient to activate control 581) that is continuous with housing 510, such as to avoid a gap between housing 510 and control 581. In some embodiments, a water-tight design of external device 500 comprises a housing 510 including at least a portion with a sufficiently thin wall thickness to allow flexing sufficient such that a user (e.g. a user's finger) can flex the housing and activate a mechanical switch positioned within housing 510 proximate the flexible portion. Alternatively or additionally, a water-tight design of external device 500 can comprise a housing 510 including one or more holes into which a mechanical switch can be inserted or accessed (e.g. via a finger of a user) combined with a water-tight overmold (e.g. silicone overmold) positioned over at least a portion of the housing 510 (e.g. over at least the holes in housing 510).

[329] Referring now to Figs. 4A-B, perspective views of an electronic assembly of implantable device 200 are shown, consistent with the present inventive concepts. In Fig. 4A, electronic assembly 255 is shown in an unfolded state, and in Fig. 4B, electronic assembly 255 is shown in its manufactured, folded state. Electronic assembly 255 can include a desiccant and/or other drying agent, drying agent 2551. Drying agent 2551 can be configured to remove any moisture that is captured within housing 210 during the manufacturing process, and/or any moisture that enters the interior of housing 210 after manufacturing (e.g. while implanted in the patient via a small leak). In some embodiments, drying agent 2551 comprises getter material. Implantable device 200 can be constructed such that the "free space" within housing 210 is relatively small (e.g. due to efficient packaging of implantable device 200 components within housing 210). The relatively small free space has a negative impact on the tolerance to moisture, and thus drying agent 2551 provides a significant advantage. In some embodiments, electronic assembly 255 comprises an integrated circuit 2552 which is operatively connected to circuit board 2553, and drying agent 2551 (e.g. getter material) is positioned on a top surface of integrated circuit 2552, as shown in Figs. 4A-B. In some embodiments, drying agent 2551 is positioned at multiple locations within housing 210.

[330] Referring now to Figs. 5A-H, various views of an electronic assembly of implantable device 200 are illustrated, consistent with the present inventive concepts. Electronic assembly 255 is shown in various unfolded, folded, and partially folded states, such as is described hereabove in reference to Figs. 4A-B. Electronic assembly 255 can comprise one or more of: portion 2553a which includes feedthrough 2556; portion 2553c, which includes one or more capacitors 2554c; portion 2553d, which can include antenna 240 (not shown) and opening

2557b; and/or portion 2553b which is operably connected to portions 2553a, 2553c, and/or 2553d; each as shown. Electronic assembly 255 can further include tabs 2553e and 2553f as shown, which can be used to secure portions of electronics assembly 255 to each other.

[331] Figs. 5C through 5F show a series of steps of folding electronic assembly 255. In Fig. 5C, the arrow shown indicates the direction in which portion 2553c is to be subsequently folded (e.g. rotated as performed by a person or machine of a manufacturer of implantable device 200). In Fig. 5D, portion 2553c has been folded approximately 180° as shown, portion 2553a has been rotated approximately 90° also as shown, and the arrow shown in Fig. 5D indicates the direction portion 2553d is to be subsequently folded. In Fig. 5E, portion 2553d has been folded approximately 180° as shown, and the arrow shown in Fig. 5E indicates the direction portion 2553a is to be subsequently folded. In Fig. 5F, portion 2553a has been folded approximately 90° as shown.

[332] When electronic assembly 255 is in its folded final state, as shown in Figs. 5F-H, capacitors 2554c of portion 2553c are positioned in an open space, space 2557a of the assembly, providing volumetric efficiency (e.g. reduced size of the final assembly). In some embodiments, opening 2557b and portion 2553c are sized and arranged to frictionally engage, such as to cause electronic assembly 255 to tend to remain (e.g. during the manufacturing process) in the folded state shown in Figs. 5F-H.

[333] **Referring now to Figs. 6A-C**, perspective, end, and side views of a partially assembled portion of implantable device 200 is illustrated, consistent with the present inventive concepts. Implantable device 200 includes housing 210, which is shown partially transparent for illustrative clarity. In some embodiments, electronic assembly 255 is manufactured with a supporting frame, such as to improve volumetric efficiency of electronic assembly 255 and housing 210 (e.g. minimize the volume of implantable device 200). The various components of implantable device 200 within housing 210, such as electronic assembly 255 (including its components) can be assembled as described herein, without a separate frame (e.g. without a separate stabilizing frame). Electronic assembly 255 can be stabilized (e.g. solely stabilized) via attachment to feedthrough 2556, which is in turn attached to housing 210, as shown.

[334] In some embodiments, implantable device 200 comprises a length, length 200L shown, that is at least two times the magnitude of the height of device 200, height 200H shown. In these embodiments, implantable device 200 can comprise a width, width 200W shown, that is also at least 1.5 times the magnitude of the height 200H. These minimum aspect ratios (the ratios of each of length 200L and width 200W as compared to height 200H) can be chosen to prevent flipping of device 200 after implantation.

[335] Referring now to Figs. 7A-C, perspective, top, and side views of an implantable device 200 are shown, the device 200 including a connector for attaching to two leads 265, consistent with the present inventive concepts. Fig. 7D shows a magnified view of a distal portion of connector 280', including fastener 284. Implantable device 200, with certain components shown as partially transparent for illustrative clarity, includes a pigtail or other connecting assembly, connector 280' shown, which is attached to housing 210 and surrounds feedthrough 2556. In the embodiment of Figs. 7A-C, connector 280' comprises a dual connector configured to operably attach (e.g. electrically and mechanically attach) to two leads 265 (e.g. leads 265 not shown but configured to be attached during a clinical procedure in which implantable device 200 is implanted in a patient). Connector 280' can be configured to electrically, mechanically, fluidly, optically, and/or sonically attach one or more components within housing 210 to one or more components (e.g. one or more stimulating elements 260) of lead 265. Connector 280' includes two conduits, conduits 282a and 282b as shown. Connector 280' also includes two engagement assemblies 283a and 283b (singly or collectively connector 283), which each include a set screw and/or other securing element, fasteners 284a and 284b (singly or collectively fastener 284). Each engagement assembly 283 includes an opening, ports 285a and 285b (singly or collectively port 285). Each port 285 is configured to slidably receive the proximal portion of a lead 265, such as to operably connect (e.g. electrically or otherwise operably connect) to one or more conduits (e.g. wires, linkages, tubes, optical fibers, and/or wave guides) of lead 265 that are operably attached to one or more stimulating elements 260 (e.g. electrode-based stimulating elements) or other components of lead 265. Each port 285 connects to one or more filaments (e.g. wires) of the associated conduit 282 (filaments not shown but traveling proximally and electrically and/or otherwise operably connecting via feedthrough 2556 to one or more components internal to housing 210). Each fastener 284 is configured to be rotated by a screwdriver or other tool, driver 286 (shown in Fig. 7A), when the proximal portion of lead 265 is inserted into a port 285, such that engagement assembly 283 frictionally engages lead 265 (via fastener 284) such as to prevent detachment of lead 265 from connector 280'.

[336] In some embodiments, each engagement assembly 283 comprises a portion that protrudes outward from the body portion of connector 280' creating a "bump" portion. In some embodiments, engagement assemblies 283 are positioned such that the bump portion extends along a line parallel with the top and bottom surfaces of implantable device 200, such that when the implantable device 200 is implanted in the patient, with its top surface parallel to the patient's skin, the bump portions of engagement assemblies 283a and 283b do not exert a force (e.g. does not exert a rubbing force) to the patient's skin (since the bump portion of each

engagement assembly 283 extends in a direction parallel to the skin surface as opposed to orthogonal to it).

[337] Housing 210 of implantable device 200 can include an extension portion, sealing element 205 shown. Sealing element 205 can surround feedthroughs 2556, and it can be created in a molding process (e.g. a molding process in which an overmold is applied to the feedthrough portion of housing 210). In some embodiments, a first portion (e.g. a first molded portion) of sealing element 205 is applied to feedthroughs 2556 (e.g. to create a seal around feedthroughs 2556 and the associated electrical connections), and a second portion (e.g. a second molded portion) of sealing element 205 is subsequently applied to the first portion and other locations of housing 210. Sealing element 205 can comprise epoxy.

[338] Implantable device 200 can comprise a mechanical port, such as port 2111 shown, which is configured to engage an insertion tool (e.g. insertion tool 6511 described herein). Port 2111 can comprise a recess in sealing element 205 (e.g. the cylindrical recess shown in Figs. 7A-B), or it can comprise a recess positioned in another location of housing 210.

[339] While the embodiment of Figs. 7A-D shows an implantable device 200 with a dual connector 280' which can be attached to two leads 265, it should be appreciated that a connector 280 can be configured to attach to a single lead 265, and the bump portion of the single engagement assembly 283 can extend in a direction parallel to the patient's skin surface.

[340] **Referring now to Figs. 8A-C**, perspective, side sectional, and perspective transparent views of an anchoring element are illustrated, consistent with the present inventive concepts. As described hereabove in reference to Fig. 1, implantable device 200 can include one or more anchoring elements, such as anchoring element 221 shown in Figs. 8A-C. Anchor element 221 can be configured to slidably receive, via lumen 2211, an elongate portion of lead 265 (e.g. not shown, but such that the elongate portion of lead 265 passes thru lumen 2211 from one end of anchor element 221 to the other). Anchor element 221 includes a compression assembly 2219. Compression assembly 2219 can include a housing 2212, with lumen 2211a therethrough. A translatable element 2213 is operably attached to a set screw 2214, and element 2213 is positioned within housing 2212 such that translatable element 2213 translates in a direction perpendicular to the axis of lumen 2211 when set screw 2214 is rotated. Translatable element 2213 includes a lumen 2211b. Lumen 2211b can be positioned coaxial with lumen 2211a, such as when set screw 2214 is rotated such that lumen 2211b is aligned with lumen 2211a. Housing 2212 can comprise a shaped opening, configured to slidably receive translatable element 2213, such that translatable element 2213 can translate as described, but not rotate. Housing 2212 can comprise a circular opening, configured to receive set screw 2214, such that set screw 2214 can

rotate within housing 2212 and rotatably engage translatable element 2213. Housing 2212 can comprise a recess 2216, configured to engage a flange 2217 of set screw 2214. Flange 2217 can engage with recess 2216 such that set screw 2214 can rotate within housing 2212, but not translate within housing 2212, therefore capturing set screw 2214 (e.g. such that set screw 2214 is always maintained within compression assembly 2219, regardless of the number of times set screw 2214 is rotated in either direction). Compression assembly 2219 can include a compression sleeve 2215, positioned within lumens 2211a,b, as shown. Rotation of set screw 2214 in a first direction (e.g. in a clockwise direction) causes translatable element 2213 to translate towards set screw 2214, and this translation causes compression sleeve 2215 to frictionally engage an inserted lead 265 that is positioned within lumen 2211. Subsequent rotation of set screw 2214 in the opposite direction, causes translatable element 2213 to translate in the opposite direction, disengaging sleeve 2215 from lead 265.

[341] Compression assembly 2219 can comprise a compression length (i.e. the length of lead 265 that is compressed by assembly 2219) that is above a minimum threshold, such as to compress lead 265 along a sufficiently long segment of lead 265 (e.g. a sufficiently long segment to avoid adversely crimping lead 265), such as a segment of at least one times, or at least two times the diameter of the lead (e.g. the diameter of the lead at the point of compression). In some embodiments, the compression length of compression assembly 2219 comprises a length of at least 0.051mm, at least 0.102mm, or at least .200mm. In some embodiments, compression assembly 2219 compresses lead 265 along two or more discrete segments.

[342] Compression assembly 2219 can be configured to radially compress lead 265 at least 10% of the diameter of the lead (e.g. a lead with an uncompressed diameter of 1.3mm would be compressed at least 0.13mm), and/or no more than 33% of the diameter of the lead (e.g. a lead with a compressed diameter of 1.3mm would be compressed no more than 0.43mm).

[343] Anchor element 221 can include one or more fixation points, circumferential recess 2218 (e.g. such as recesses 2218a and 2218b shown). Surgical clips or sutures can be placed around a recess 2218 and into tissue, such as to fixate anchor element 221 and an inserted lead 265 to tissue.

[344] **Referring now to Fig. 9**, a top view of an electronic assembly of implantable device 200 is illustrated, consistent with the present inventive concepts. Electronic assembly 255 is shown in an unfolded state. Electronic assembly 255 comprises various portions, such as regions B, C, D, and E shown. Electronic assembly 255 can comprise one or more portions of insulating tape (e.g. a polyimide tape) and/or other insulating material portions, insulator 2558 shown. In some embodiments, an insulator 2558 is positioned over one or more regions of electronic

assembly 255 such that when assembly 255 is folded in manufacturing (e.g. as described hereabove in reference to Figs. 5A-H), opposing electrically conductive portions of assembly 255 do not contact each other. For example, an insulator 2558 can be positioned such that a DC blocking capacitor 2554 and a DC node do not electrically short together. Insulator 2558 can comprise a portion that is positioned along the sides of components C1 and L1 shown (e.g. along line A). Insulator 2558 can comprise an upper boundary that is no lower than the top surface of component L1 and no higher than the top surface of component C1. In some embodiments, adhesive is applied between components at region B and region C. In some embodiments, insulator 2558 can comprise a portion that is positioned over components C18-C23 shown (e.g. components positioned in region E). In some embodiments, a serial number label is positioned in region D.

[345] Referring now to Fig. 10, an exploded view of an external device is illustrated, consistent with the present inventive concepts. External device 500 includes housing 510, comprising top housing 510a and bottom housing 510b. Housing 510 can comprise one or more metal and/or plastic materials, such as polycarbonate and/or acrylonitrile butadiene styrene (ABS). Positioned between housings 510a-b are various components configured to transmit power and/or data to an implantable device 200, and perform other functions, as described herein. External device 500 includes electronic assembly 555, which is shown positioned on top of a copper shield, shield 556 shown. Copper shield 556 is positioned on top of a ferrite disk, disk 557, which in turn is positioned on top of antenna assembly 540. One or more screws, screws 513 (three shown), attach components 555, 556, 557, and 540 to bottom housing 510b via mating bosses 514 (three shown) into which screws 513 rotatably engage (e.g. engage threads of boss 514). In some embodiments, screws 513 are rotatably engaged with a minimum torque (e.g. to minimize gaps between the layers), such as a torque of at least 10in-oz, such as at least 14in-oz, or at least 16in-oz. In some embodiments, copper shield 556 is adhered to ferrite disk 557. In some embodiments, antenna 540 is adhered to ferrite disk 557. In some embodiments, both copper shield 556 and antenna 540 are adhered to ferrite disk 557 (e.g. in the orientation shown in Fig. 10), such as to create a laminate construction which maximizes the effectiveness of the shielding provided, and/or eliminates or at least minimizes gaps between layers that could result in detuning.

[346] External device 500 includes a battery, capacitor, or other energy storage element, power supply 570 shown. Power supply 570 can be attached to electronic assembly 555 via connector 572 shown. Connector 572 can comprise a double-sided adhesive pad. Power supply 570 can be replaceable and/or rechargeable. In some embodiments, power supply 570 comprises

a lithium ion battery. External device 500 can comprise one or more contacts positioned on the external surface of housing 510, such as contacts 571 (three shown). Contacts 571 can comprise pogo pins or other contacts that are electrically connected to charging circuitry of electronic assembly 555, such as to allow charging of power supply 570. For example, contacts 571 can be constructed and arranged to receive power from mating contacts of charger 61 as described herebelow in reference to Figs. 17A-C.

[347] External device 500 can comprise one or more user interface components, such as indicator 581 shown. Indicator 581 can comprise an indicator light and/or a display. In some embodiments, indicator 581 comprises a light pipe which is positioned above a light-emitting device such as above an LED of electronic assembly 555. In some embodiments, indicator 581 comprises a speaker or other audio output component (e.g. a buzzer). Indicator 581 can provide various information to the patient or other user, such as: status of connection with implantable device 200; battery status (e.g. battery level, low battery, and the like); program information (e.g. program number); therapy information (e.g. amplitude or other therapy level); programmer 600 connection status; and combinations of one or more of these.

[348] Referring now to Fig. 11 A-D, a perspective top view, a side view, a side sectional view, and another side sectional view and of an interface assembly for operably attaching a trialing interface 90 to two lead assemblies 265 is illustrated, consistent with the present inventive concepts. Interface connector 95 comprises housing 9510 including base 9511 and first hinged portion 9512a and second hinged portion 9512b (singly or collectively hinged portion 9512). Hinged portions 9512a and 9512b are rotatably attached to a mid-portion of base 9511, and each can rotate in the directions shown in Fig. 11B. In Fig. 11B, hinged portion 9512a is shown in an “open” position (e.g. a position in which a lead 265 can be inserted or removed), and hinged portion 9512b is shown in a “closed position” (e.g. position in which the proximal end of a lead 265 is secured in place and electrically and/or otherwise operably connected to trialing interface 90).

[349] In some embodiments, interface connector 95 is constructed and arranged such that hinged portion 9512a-b interfere with each other during rotation, such as to limit the amount of rotation each can undertake. For example, rotation of hinged portion 9512a is limited to the point at which hinged portion 9512a contacts hinged portion 9512b, e.g. location L1 shown in Fig. 11B. In some embodiments, only one of hinged portions 9512 can be opened (e.g. fully opened) at a time (e.g. due to a mechanical stop provided by contact between the hinged portion 9512a and 9512b when one is in an open position).

[350] Hinged portions 9512a and 9512b can include one or more projections, such as tabs 9513a and 9513b, respectively, as shown. Similarly, base 9511 can comprise one or more projections, such as the two tabs 9514a shown relatively opposite projection 9513a (e.g. and similar tabs 9514b not shown but relatively opposite projection 9513b). Interface connector 95 can be constructed and arranged such that a user (e.g. a clinician that implants one or more implantable devices 200) can rotate a hinged portion 9512 by engaging a hinged portion 9512 (e.g. grasping a projection 9513) and engaging base 9511 (e.g. grasping at a projection 9514) and applying a force to cause a rotation (e.g. a pivoting force to transition hinged portion 9512 from an open to closed condition, or vice versa). In some embodiments, interface connector 95 is constructed and arranged such that a user can use a single hand to transition a hinged portion 9512 from an open condition to a closed condition, or vice versa (e.g. fingers of a single hand apply opposing forces to base 9511 and a hinged portion 9512).

[351] Each hinged portion 9512 includes a lumen 9515 through which a lead 265 can be inserted when the associated hinged portion is in an open position. Subsequent closure of the hinged portion 9512 causes lead 265 to be secured within interface connector 95 and to operably connect with various components of lead 265. For example, conductive portions of lead 265, contacts 267 (e.g. contacts which are each electrically connected to a stimulation element 260), can electrically connect to one or more pogo pins or other electrical contacts of connector 95, contacts 9516.

[352] Securing of a lead 265 via inserting of lead 265 into a lumen 9515 and rotation of the associated hinged portion 9512 to a closed position, electrically and/or otherwise operably connects lead 265 to interface connector 95. Interface connector 95 includes connector 9520 which is operably attached to at least contacts 9516 via cable 9521. Connector 9520 can be operably connected to a trialing interface, such as trialing interface 90 described herebelow in reference to Figs. 12A-B.

[353] **Referring now to Fig. 12A-B**, a perspective view and a schematic view of a stimulation apparatus comprising a trialing interface and a lead connector are illustrated, consistent with the present inventive concepts. Trialing interface 90 comprises a housing, housing 9010, which surrounds an electronic assembly, assembly 9030. Electronic assembly 9030 is electrically attached to a connector, connector 9020, such as a connector with at least 10 contacts, such as approximately 18 contacts. Electronic assembly 9030 can be electrically attached to connector 9020 via cable 9021 (as shown in Fig. 12A). Trialing interface 90 further comprises interface connector 95, which includes connector 9520. Connector 9520 is configured

to electrically attach to connector 9020 (e.g. connector 9520 comprises mating contacts, such as at least 10 contacts, such as approximately 18 contacts).

[354] Interface connector 95 includes housing 9510. Interface connector 95 is configured to operably (e.g. at least electrically) attach to one or more leads 265 (e.g. removably attaching to leads 265a and 265b shown in Figs. 12A-B). Each lead 265 can include one or more stimulation elements 260a and 260b, respectively (e.g. two, four, six, eight, or more stimulation elements 260). Each lead 265 connects to interface connector 265 via connector 9540 as shown. In some embodiments, housing 9510 comprises two hinged portions, which can be positioned (e.g. via a single hand of an operator) about one or more leads 265 (e.g. as described hereabove in reference to Figs. 11A-D). In some embodiments, interface connector 95 is configured to operably attach to a single lead 265. In some embodiments, interface connector 95 is configured to operably attach to three or more leads 265, such as four leads 265. Interface connector 95 can include cable 9521, as shown in Fig. 12A, which electrically attaches connector 9520 to connector 9540.

[355] Electronic assembly 9030 is configured to provide stimulation energy to one or more stimulation elements 260 of one or more leads 265 (e.g. via connectors 9020, 9520, and 9540). As described hereabove in reference to Fig. 1, interface connector 95 can comprise a single-use disposable component, used in a single clinical procedure on a single patient, while the remaining portions of trialing interface 90 (e.g. housing 9010 and its surrounded components) are for use in multiple clinical procedures (e.g. on the same or multiple patients).

[356] In some embodiments, electronic assembly 9030 includes detection circuitry 9031, and interface connector 95 comprises detection circuitry 9531. Detection circuitry 9031 is electrically connected to one or more contacts of connector 9020, and detection circuitry 9531 is connected to one or more mating contacts of connector 9520. Via circuitry 9031 and 9531, trialing interface 90 is configured to detect proper connection of connector 9520 to connector 9020 (e.g. perform one time and/or repeated checks that a proper electrical and/or other connection exists between connectors 9520 and 9020). In some embodiments, detection circuitry 9531 comprises a connection (e.g. an electric short or other known resistance connection) between two or more contacts of connector 9520, and electronic assembly 9030, via detection circuitry 9031 can detect a proper connection between connectors 9020 and 9520 has been made based on this connection of known resistance. In some embodiments, the connection is determined using an alternating current (AC) signal. Avoidance of a direct current (DC) signal is advantageous as it avoids uncomfortable and/or unsafe stimulation of the patient (e.g. due to a bend and/or break in lead 265, or other event that causes shorting of wires of lead 265). In some embodiments, the AC signal provided by electronic assembly 9030 comprises a digital pulse

(e.g. with a pulse width of approximately 2 μ sec and at a voltage level less than 10V, such as less than 5V, or approximately 3V). Electronic assembly 9030 is configured to detect a “high” state during the pulse, and then a “low” state after the pulse. This check for a proper connection can be repeated (e.g. at approximately a 10Hz rate), and trialing interface 90 can detect if a connect or disconnect of connectors 9020 and 9520 occurs (e.g. a connect or disconnect of interface connector 95 from the remaining portion of trialing interface 90).

[357] In some embodiments, trialing interface 90 is configured to detect proper connection of one or more leads 265. For example, trialing interface 90 can be configured to perform an impedance measurement that provides information about the state of connectivity of lead 265 with both trialing interface 90 and tissue. A high (e.g. open) impedance is indicative of an improper connection.

[358] In some embodiments, if trialing interface 90 detects connectors 9020 and 9520 being connected (i.e. detects connectors 9020 and 9520 transitioning from a disconnected state to a connected state), and electronic assembly 9030 is currently (e.g. at the time of the connection) attempting to deliver a stimulation waveform (i.e. deliver stimulation energy) to the patient (e.g. via one or more stimulation elements 260), electronic assembly 9030 can be configured to stop signal delivery to the patient (e.g. avoid full amplitude signal delivery to the patient), and initiate a new stimulation delivery in which amplitude level is slowly ramped up (e.g. to avoid the patient getting full stimulation energy at the time of connection). For example, the amplitude can be ramped up over a period of 1s to 10s to avoid full amplitude delivery at the time of a connection that may be perceived as unpleasant by the patient. In some embodiments, trialing interface 90 is configured to prevent delivery of full amplitude stimulation energy (and/or any significant amplitude of stimulation energy) unless a proper connection between connectors 9020 and 9520 is detected.

[359] **Referring now to Fig. 13A-C**, perspective views of a single connector 215' attached to a connector 220 and a dual connector 215'' attached to a connector 220, respectively, are illustrated, consistent with the present inventive concepts. As shown in Fig. 13A, the array of pins 206 of connector 220 are slidingly received by the array of receptacles 216 of connector 215'. Connector 215' includes single conduit 262 of lead 265 or a single conduit 282 of lead connection assembly 280. As shown in Fig. 13B, the array of pins 206 of connector 220 are slidingly received by the array of receptacles 216 of connector 215''. Connector 215'' includes dual conduits 262a, 262b of two leads 265 or conduits 282a, 282b of two lead connection assemblies 280 or a dual lead connection assembly 280'. In some embodiments, as shown in both Figs. 13A and 13B, a sealing element 205 is applied to surround at least a portion of

housing 210, connector 220, and/or connector 215, such that sealing element 205 prevents contamination from entering locations within housing 210 and/or adversely affecting the connection made between connector 215 and an attached component.

[360] Referring additionally to Fig. 13C, apparatus 10 can include one or more stylets 1700, such as stylets 1700a and 1700b shown, and implantable device 200 can comprise one or more stylet entry ports, such as ports 207a and 207b shown. Each entry port 207 can be connected to a lumen of a lead 265 and/or lead connection assembly 280, such as lumens 208a and 208b. Each stylet 1700 can include an elongate filament 1701 which can be connected to a handle 1702, (e.g. filaments 1701a and 1701b connected to handles 1702a and 1702b, respectively). Each filament 1701 can be inserted into a lumen 208 such as to provide rigidity in the advancement of the lead 265 (or lead connection assembly 280) through tissue. Filament 1701 can comprise a filament that is flexible and/or malleable, such as a malleable filament whose shape can be curved or otherwise modified as desired to assist in the insertion of a lead 265 through tissue (e.g. a lead comprising one or more stimulation elements 260 as shown). In some embodiments, a single stylet 1700 is used to sequentially advance a first lead 265a and then a second lead 265b. Each entry port 207 includes an opening with a trajectory that allows stylet 1700 to be positioned eccentric to the associated lumen 208. In other words, the proximal portion of each lumen 208 (the portion proximate opening 207 is curved as shown. This configuration of lumen 208 and opening 207 avoids any additional volume needed to be added to housing 210, while allowing stylet 1700 to remain centered in the associated lead 265 such that insertion of lead 265 is performed with a similar technique to that used when inserting a lead not attached to a stimulator housing.

[361] In some embodiments, sealing element 205 (or another portion of housing 210) comprises a receptacle for engaging an implantation tool (e.g. insertion tool 6511 described herein), such as port 2111 described hereabove in reference to Figs. 7A-B.

[362] Referring now to Figs. 14A-B, perspective views of an implantable device 200 are illustrated, consistent with the present inventive concepts. Implantable device includes housing 210, and connector 220 as described herein. Connector 220 comprises an array of pins 206 that are slidably received by an array of receptacles 216 of connector 215'. Connector 215'' includes dual conduits 262a, 262b of two leads 265 or conduits 282a, 282b of two lead connection assemblies 280 or a dual lead connection assembly 280'. In some embodiments, a sealing element 205 is applied to surround at least a portion of housing 210, connector 220, and/or connector 215, such that sealing element 205 prevents contamination from entering

locations within housing 210 and/or adversely affecting the connection made between connector 215 and an attached component.

[363] Implantable device 200 can comprise one or more stylet entry ports, such as ports 207a and 207b shown. Each entry port 207 can be connected to a lumen of a lead 265 and/or lead connection assembly 280, such as lumens 208a and 208b, such as to cooperate with a stylet 1700 as described hereabove in reference to Fig. 13C.

[364] A set of wires 217 are electrically connected to the array of pins 206. For illustrative clarity, only 4 wires 217 are shown in Figs. 14A-B, however each pin 206 is electrically connected to a separate wire 217 (e.g. 32 pins 206 are connected to 32 separate wires 217). The array wires 217 travel into dual conduits 262a, 262b of two leads 265 or conduits 282a, 282b of two lead connection assemblies 280 or a dual lead connection assembly 280'. Wires 217, at their point of connection to pins 206, can be arranged in 2 linear arrays of wires positioned in 2 planes (e.g. when pins 206 are arranged in two rows as shown). Each wire 217 can travel, in a path comprising a curvilinear trajectory, and in a relatively parallel arrangement to one or more wires 217 in proximity to it, and enter into a conduit 262a, 262b of a two lead 265 or a conduit 282a, 282b of a connection assembly 280 or a dual lead connection assembly 280'. The collective pathways of wires 217 can be arranged to avoid the lumen of ports 207.

[365] **Referring now to Figs. 15A-L**, a series of views of an implantation procedure for implantable device 200 is illustrated, consistent with the present inventive concepts. Implantable device 200 can be configured as a "ported-version", in which leads 265 are attachable by the clinician, and/or an "integrated-version" (a pre-attached-version), in which leads 265 are attached during the manufacturing of implantable device 200. As described herebelow, each implantable device 200 can be implanted in the patient using a single incision (i.e. avoiding multiple incisions). Implantable device 200 can be implanted using both a tunneling tool, tool 6504, for creating a tunnel in tissue, a lead pushing tool, tool 6505, configured to push lead 265 through that tunnel, and/or other tools as described herebelow. Tunneling tool 6504 can comprise a handheld device (e.g. with an effective length of approximately 10cm) that is used to create a subcutaneous pathway and pocket for the placement of implantable device 200. The implantation steps below are described in reference to positioning implantable device 200 proximate the patient's spine.

[366] The patient can be positioned, prepped, and draped per clinical protocols. A local anesthetic can be injected at the needle insertion site. A needle assembly 6506 including a needle 6506a and a stylet 6506b can be inserted into the epidural space, such as with a bevel of the needle facing up at an angle of 45° or less. The stylet 6506b is then removed from the needle

6506a. Proper positioning of the needle tip in the epidural space can be performed using the “loss-of-resistance” technique.

[367] Lead 265 can include a pre-loaded bent stylet, stylet 6507. This stylet 6507 can extend to the tip of the lead. The lead 265 including its stylet 6507 can be inserted through the insertion needle 6505a. In some embodiments, lead 265 includes multiple stylets 6507 (e.g. multiple different stylets 6507a, 6507b, and so on). If exchange of a stylet 6507 is desired, the existing stylet (e.g. a stylet 6507a) can be carefully pulled out of the lead 265, and a different stylet (e.g. a stylet 6507b) inserted. If resistance is encountered during a stylet 6507 insertion, rotation of the lead 265 and/or stylet 6507 can be performed (e.g. a rotation that occurs after a small withdrawal of the stylet 6507).

[368] Lead 265 including a stylet 6507 can be advanced to the appropriate vertebral level under fluoroscopic guidance. A sufficient length of lead 265 (e.g. at least 10cm, or approximately three vertebrae) should reside in the epidural space (e.g. to aid in stabilization of lead 265).

[369] If multiple leads 265 are to be implanted, the above steps can be repeated for each lead 265.

[370] **Referring to Fig. 15A**, while holding lead 265 in place, the interface connector 95 is connected to the proximal end of each lead 265 by opening a hinged lid of connector 95 and inserting the proximal end of each lead 265 into the access port on the side of the lid. A verification that lead 265 is fully inserted into connector 95 can be performed, such as through a visual observation port on the top of the hinged lid(s). The lid(s) is then closed, which can be confirmed by the presence of a snapping sound provided by connector 95. If a single lead 265 is inserted, it can be inserted into a predetermined port of connector 95 (e.g. the bottom access port A shown in Fig. 15a).

[371] In some embodiments, the female end of interface connector 95 (e.g. a larger end) can be connected to an extension cable of apparatus 10. This extension cable can be connected to a trial stimulator device of apparatus 10, such as trialing interface 80 and/or 90 described herein.

[372] In some embodiments, the connections can be tested (e.g. impedance tested), such as by using clinician programmer 600” described herein. Inadequate connections can be reconnected and retested until a satisfactory result is achieved.

[373] If paresthesia coverage is desired, an appropriate set of stimulation parameters can be identified, such as parameters beginning at a relatively medium pulse width and frequency range. The stimulation can be delivered, and an increase in amplitude performed while asking the

patient questions (e.g. close-ended questions) to identify that patient's perception threshold, a discomfort threshold, and/or an area of coverage (e.g. paresthesia coverage).

[374] In some embodiments, a fluoroscopic, ultrasonic, and/or other image of placement of lead 265 is taken, such as for record-keeping purposes.

[375] If performing a "staged trial", using a lead 265 to be permanently implanted, interface connector 95 can be detached from lead 265, and anchoring of lead 265 can be performed (e.g. as described herebelow in reference to Fig. 15B). If performing a "temporary trial" using a short term temporary implanted lead (e.g. a temporarily implanted lead 265), the excess portion of lead 265 can be coiled and the lead 265 and interface connector 95 can be covered (e.g. with gauze and dressing).

[376] **Referring now to Fig. 15B**, anchoring of lead 265 can be performed by first removing the lead 265 stylet 6506, such as using fluoroscopy or other imaging to ensure that the lead 265 position does not change. As shown in Fig. 15B, a small midline incision can be made at the lead 265 skin entry site. An anchor element 221 can be placed over lead 265 and down to the supraspinous ligament or down to the deep fascial tissue. A confirmation that the tip of the anchor element 221 has been pushed into the ligamentous tissue can be performed.

[377] A suture can be placed in the supraspinous ligament or deep fascia, then lead 265 can be inserted through the suture and the suture tied off (e.g. to an eyelet of anchor element 221). After suturing to the eyelet, a set screw of anchor element 221 can be tightened (e.g. using a torque wrench, such as torque wrench 6508 described herein). A clicking sound can be provided when anchor 211 is locked. After the set screw is tightened, a second eyelet of anchor element 221 can be sutured to the supraspinous ligament or deep fascia. The secure attachment of lead 265, via anchor element 221, can be checked. A check can be performed to ensure that lead 265 has not moved, such as by performing a test stimulation and/or using imaging (e.g. fluoroscopic imaging) as necessary. If it is determined that lead 265 has undesirably migrated, the set screw can be loosened, lead 265 repositioned, and the set screw retightened. This process described in reference to Fig. 15B can be repeated for placement of additional leads 265.

[378] Implantation of a **ported-version** of implantable device 200 is described herebelow in reference to Figs. 15C-G.

[379] If a staged trial was performed, as described hereabove, the following steps 1-5 are performed. If it wasn't a staged trial, only steps the 3-5 are performed.

[380] (1) The lead extension is cut (e.g. with scissors or other cutting tool of apparatus 10), proximal to its connector. The remaining portion of the lead extension is pulled out through the exit wound site and discarded.

[381] (2) Using torque wrench 6508, a set screw of a connector boot of the lead extension is loosened (e.g. rotated until a click is heard). The connector boot is removed and discarded.

[382] Steps (1) and (2) can be repeated for additional leads 265 that have been inserted into the patient.

[383] (3) The proximal end of the lead 265 can be cleaned, and then inserted into the implantable device 200 connector (e.g. until it is fully inserted and a set screw ring is located directly under the set screw).

[384] (4) A check that the lead 265 is fully inserted is performed.

[385] (5) Using torque wrench 6508, the set screw of implantable device 200 is tightened (e.g. until a click is heard, indicating the lead 265 is properly secured).

[386] Steps (3) through (5) can be repeated for any additional leads 265 that have been inserted into the patient.

[387] **Referring now to Fig. 15C**, an external device 500 can be included in a sterile bag, sterile bag 6509, as shown. The external device 500 can be positioned proximate the implantable device 200 that has been implanted in the patient, such as to perform a test stimulation. A check of a desired physiologic response can be performed during the test stimulation. External device 500 can be oriented such that any buttons or other controls of user interface 580 of external device 500 are facing away from the implantable device 200 when performing the test stimulation.

[388] **Referring now to Fig. 15D**, the desired implantation site for the implantable device 200 can be located lateral to the midline incision. This final implantation site can be pre-determined via consultation with the patient prior to the implantation procedure. With the external device 500 still in the sterile bag 6509, the periphery of the external device 500 can be traced with a surgical marker of apparatus 10, sterile marking tool 6510 shown, such as while the external device 500 is centered over the desired implantation site of implantable device 200.

[389] **Referring now to Fig. 15E**, the lower distal end of a tunneling tool of apparatus 10, such as tunneling tool 6504 described herein, is inserted into the midline incision, with the top portion of tunneling tool 6504 positioned above the skin (e.g. to function as a depth guide and/or to gauge length). Using blunt dissection, a subcutaneous tissue path from the midline incision site to the final implant location of implantable device 200 is performed by advancing the tip of tunneling tool 6504 until the tip of tunneling tool 6504 is approximately the length of implantable device 200 from the center of the traced outline of external device 500 described hereabove. Tunneling tool 6504 can include markings 6504a (e.g. markings equidistantly spaced, such as at a separation distance of 1cm) that are used to measure the distance from the

incision site to the final implant location of implantable device 200. Tunneling tool 6504 can be maintained relatively shallow during tissue tunneling, without puncturing the skin. The pocket can be irrigated, such as with sterile saline solution and/or antibiotic solution. Tunneling tool 6504 is configured to cause implantable device 200 to be positioned below the skin at a constant depth and approximately parallel to the skin, such as to ensure successful transmissions of power and/or data between implantable device 200 and an external device 500 during use.

[390] Referring now to **Fig. 15F**, tunneling tool 6504 can be used as a template.

Tunneling tool 6504 can be placed on the skin and the tunneling path traced using the top portion of the tool 6504 from the midline incision to the center of the outline of the external device 500 location.

[391] The tip of a tool configured to insert implantable device 200, insertion tool 6511 (shown in Fig. 15G), is inserted into a receptacle of implantable device 200 (e.g. port 2111 described hereabove in reference to Fig. 7A-B), such as a receptacle proximate the location where lead 265 or a lead extension protrudes from housing 210 of implantable device 200. Insertion tool 6511 can be sized and configured to frictionally engage implantable device 200 during the positioning process.

[392] Referring now to **Fig. 15G**, the tunneling tool 6504 (not shown in Fig. 15G) can be withdrawn until only its tip portion remains within the tissue tunnel (e.g. in order to retain the tunnel location and path). The insertion tool 6511, with attached implantable device 200 is made available (e.g. positioned proximate the tunnel location) as shown. The tunneling tool 6504 is then completely removed, and soon thereafter the implantable device 200 is advanced into the tissue tunnel (e.g. in a particular orientation, such as with a logo or other marker facing toward the patient's skin). Forceps can be used to lift the superior edge of the midline incision to further facilitate insertion.

[393] The implantable device 200 is advanced with a pushing motion along the subcutaneous tissue path until the device 200 is located at the center of the external device 500 marked outline. Verification of proper placement can be performed, such as using palpation.

[394] If excessive resistance is encountered upon initial insertion of the implantable device 200 into the tissue tunnel created by tunneling tool 6504, a check that the implantable device 200 is positioned (e.g. oriented) properly within the tissue tunnel can be performed. If insertion tool 6511 is detached from the implantable device 200, a gentle pull back on the lead(s) 265 can be performed to remove the implantable device 200 from the tissue tunnel.

[395] If excessive resistance inserting the implantable device 200 is encountered after multiple attempts, alternative tools, such as forceps, can be used for placement.

[396] Once properly positioned, while slight pressure is applied to the implantable device 200, insertion tool 6511 is detached (e.g. by simultaneously applying a pulling force), leaving the implantable device 200 in place.

[397] A check of connections can be performed, such as using an impedance measurement (e.g. as described herein). If impedance is at an undesired level, connections can be checked and/or remade, and an impedance check repeated.

[398] Any excess length of lead 265 can be looped and/or tucked into the incision site and/or tissue tunnel.

[399] The midline incision is closed, and the wound dressed.

[400] While the method described in reference to Figs. 15C-G provides one method of implanting a ported-version of an implantable device 200, alternative methods can be performed. For example, one alternative method is described immediately herebelow.

[401] Leads 265 are placed and anchored, for example as described hereabove.

[402] The final pocket site for the implantable device 200 is located as desired (e.g. a location pre-determined with the patient prior to the implantation surgery). With an external device 500 in a sterile bag 6509, the outline of the external device 500 is traced with sterile marking tool 6510 with the external device 500 centered over the desired implantable device 200 final pocket site.

[403] A small incision is made near the desired pocket site.

[404] The desired route of the tissue tunnel is marked on the patient's skin.

[405] A local anesthetic is administered along the intended tissue tunnel path.

[406] If necessary or at least desired, a tissue tunneling device, tunneling tool 6512, is bent to conform to the patient's body. Tunneling tool 6512 can comprise a handle, a malleable (e.g. stainless steel) rod with a sharp tip that is used to create a tissue tunnel (i.e. a subcutaneous pathway) for the passage of lead 265 and/or a lead extension. Tunneling tool 6512 can further include a sleeve (e.g. a plastic sleeve).

[407] Tunneling tool 6512 can be used to create a subcutaneous tunnel between the lead(s) 265 incision site and the implantable device 200 pocket incision site until the tool 6512 is visible and accessible at the exit point (e.g. the exit of the tunnel at the surface of the skin).

[408] Once in place in the created tissue tunnel, a handle (e.g. a loop) of tunneling tool 6512 can be grasped with one hand, while holding its sleeve with the other hand. The shaft of the tool 6512 can be pulled out through the sleeve, leaving the sleeve in place.

[409] A lead 265 (or lead extension) can be pushed through the tool 6512 sleeve, and then the sleeve withdrawn from the tissue tunnel.

[410] The proximal end(s) of the lead 265 can be pulled out of the exit point.

[411] The proximal end(s) of the lead 265 can be cleaned, and then inserted into the implantable device 200 connector (e.g. until it is fully inserted and a set screw ring is located directly under the set screw), such as is described hereabove in reference to Fig. 15B hereabove. Further implantation steps can be performed as described in reference to Figs. 15B-G.

[412] Implantation of an **integrated-version** of implantable device 200 is described herebelow in reference to Figs. 15H-K.

[413] **Referring now to Fig. 15H**, the patient is positioned, prepared, and draped. A local anesthetic is injected at the needle insertion site. Under fluoroscopic guidance, the distal portion of a tearaway introducer, introducer 6513, has been inserted into the patient (e.g. into the epidural space of the patient). In the embodiment of Fig. 15H, two introducers 6513 have been inserted (e.g. to implant two leads 265).

[414] Introducer 6513 can include needle 6513a, stylet 6513b, and sheath 6513c. During insertion, the angle of the insertion needle 6513a of introducer 6513 can be maintained at an angle of 45° or less. Steep angles increase the insertion force of stylet 6513b, and can also present more of an opportunity for stylet 6513b to pierce lead 265 and cause tissue damage. The distance between the sheath 6513c opening and the needle 6513a opening, can be below a maximum, such as is described herebelow in reference to Fig. 16. This distance can be considered by the clinician when entering the epidural space.

[415] Stylet 6513b is then removed from sheath 6513c. Entry into the epidural space can be verified (e.g. using the loss-of resistance technique).

[416] Needle 6513a is then removed from sheath 6513c.

[417] Lead 265 is loaded (e.g. pre-loaded) with stylet 6507, such that stylet 6507 extends to the tip of lead 265. In some embodiments, multiple leads 265 are each loaded with a stylet 6507, such as the two leads 265 and two stylets 6507 shown in Fig. 15I. Subsequently, each lead 265 and loaded stylet 6507 is slowly inserted through a sheath 6513c.

[418] In some embodiments, an exchange of stylet 6507 can be performed (e.g. with a stylet 6507 of a different configuration to the stylet loaded into lead 265), such as a stylet 6507 exchange as described hereabove.

[419] In some embodiments, to facilitate loading of a stylet 6507 into an integrated lead 265, the lead 265 is first aligned with the general direction of the stylet lumen path of the implantable device 200, **as shown in Fig. 15J**. Once aligned, the tip of the stylet 6507 can be inserted into the associated opening of implantable device 200 and stylet 6507 advanced into lead 265.

[420] Subsequently, lead 265 can be advanced to the appropriate vertebral level, such as an advancement performed under visual guidance (e.g. fluoroscopy and/or ultrasound imaging), **as shown in Fig. 15K**. Sufficient length of lead 265 (e.g. at least 10cm and/or approximately three vertebrae) should reside in the epidural space (e.g. to aid in stabilization of lead 265).

[421] If implantable device 200 comprises dual leads 265, the second lead 265 can be implanted in a similar fashion.

[422] While holding the one or more leads 265 in place, impedance levels can be checked and/or test stimulation can be performed (e.g. using an external device 500 positioned in sterile bag 6509). If paresthesia coverage is desired, an appropriate set of stimulation parameters can be identified, such as parameters beginning at a relatively medium pulse width and frequency range. The stimulation can be delivered, and an increase in amplitude performed while asking the patient questions (e.g. close-ended questions) to identify that patient's perception threshold, a discomfort threshold, and/or an area of coverage (e.g. paresthesia coverage).

[423] The tearaway introducer sheath 6513c can be removed (e.g. each half at a time) by grasping hub tabs of the sheath 6513c **as shown in Fig. 15L**.

[424] Anchoring of lead 265 can be performed, such as using anchor element 221 as described hereabove in reference to Fig. 15B.

[425] Proximal to the one or more anchor elements 221, a small loop in the lead 265 can be created (e.g. to create slack).

[426] Implantable device 200 can be implanted in the final pocket site, as described hereabove.

[427] In some embodiments, a lead extension is positioned between implantable device 200 and lead 265 (e.g. between housing 210 and lead 265). In these embodiments, a desired location of a tissue tunnel is marked (e.g. on the patient's skin). Anesthetic is administered along the intended tissue tunnel path.

[428] If necessary or at least desired, a tissue tunneling device, tunneling tool 6512 described hereabove, is bent to conform to the patient's body.

[429] A small incision is created at the desired exit site, and the tunneling tool 6512 is prepared for use (e.g. a protective cap is removed if present).

[430] A tissue tunnel is created in the subcutaneous tissue between the midline incision and the exit site until the shaft of the tunneling tool 6512 is visible and accessible at the exit point. In order to minimize the risk of infection, tunneling can be performed away from the initial incision site, in the contralateral and superior direction.

[431] Once in place in the created tissue tunnel, a handle (e.g. a loop) of tunneling tool 6512 can be grasped with one hand, while holding its sleeve with the other hand. The shaft of the tool 6512 can be pulled out through the sleeve, leaving the sleeve in place.

[432] The proximal end of the lead 265 can be cleaned, and then inserted into a connector of the lead extension (e.g. until it is fully inserted and a set screw ring is located directly under the set screw). If an obstruction is suspected when inserting lead 265 into the lead extension, the set screw can be loosened (e.g. using torque wrench 6508) and/or the lead 265 can be gently rotated.

[433] Once proper insertion of the lead 265 is confirmed, the set screw can be tightened (e.g. using torque wrench 6508), such as a tightening that proceeds until a clicking sound is observed.

[434] An appropriately-sized pocket in the tissue is formed (e.g. using blunt dissection), on either side of the midline for coiled excess lead 265 and/or lead extension.

[435] A small loop is created in lead 265 for slack.

[436] The free end of the lead extension is passed through the sleeve of tunneling tool 6512 until it emerges from the exit site. Excess slack is removed by pulling the lead extension from the exit site.

[437] These steps can be repeated for a second lead extension.

[438] Interface connector 95 can be attached to the lead extension, such as is described hereabove in reference to Figs. 11A-D, and a test stimulation performed to verify desired response of the implantable device 200.

[439] If a staged trial using a permanent lead 265 is being performed, a small suture can be used to close the exit site of the lead extension. Tape can be placed and a stress relief loop created in the lead extension, and the wound dressed.

[440] The midline incision can be closed and covered with gauze and dressing. The lead extension can be coiled and covered with gauze and dressing at the exit site.

[441] In some embodiments, implantable device 200 is implanted to perform peripheral nerve stimulation. For example, implantable device 200 can be implanted to stimulate one or more peripheral nerves selected from the group consisting of: suprascapular nerve; brachial plexus nerve; intercostal nerve; ulnar nerve; median nerve; radial nerve; cluneal nerve; femoral nerve; ilioinguinal nerve; sacral nerve; scrotal nerve; pudendal nerve; sciatic nerve; peroneal nerve; sural nerve; tibial nerve; and combinations of these.

[442] In an implantation procedure in which peripheral nerve stimulation is to be accomplished, the patient can be positioned, prepped, and draped per clinical protocols. The area

of the patient's peripheral nerve(s) to be stimulated can be mapped and the planned trajectory marked on the skin.

[443] A local anesthetic can be injected at the needle insertion site.

[444] If necessary or desired, a puncture incision can be made before inserting a needle or introducer.

[445] A needle and/or introducer can be advanced through the incision in the direction of the peripheral nerve. If using a needle, an included stylet can be removed, leaving the needle in place. If using an introducer, an included needle can be removed leaving a sheath in place.

[446] One or more leads 265 are provided, such as including bent stylet 6507. The stylet 6507 should be positioned to extend to the tip of the lead 265. The lead 265, including stylet 6507, is slowly inserted, through the insertion needle or sheath.

[447] If an exchange of stylet 6507 is desired, the existing stylet 6507 can be pulled out, and a different stylet 6507 inserted, as described hereabove.

[448] These steps can be repeated if a second lead 265 is to be implanted.

[449] While holding lead 265 in place, the needle or sheath is pulled back to expose contacts of lead 265.

[450] While holding lead 265 in place, interface connector 95 is connected to the proximal end of lead 265 by opening the hinged lid(s) of connector 95 and inserting the proximal end of lead(s) 265 into the access port on the side of the lid. A verification that the lead 265 is fully inserted can be performed (e.g. through a visual observation port on the top of the hinged lid). The lid is closed (e.g. until a snapping sound is observed). If a single lead 265 is to be attached, the lead 265 can be connected to access port A, **as shown in Fig. 15M**.

[451] In some embodiments, a cable extension can be used to connect lead 265 to interface connector 95, such as to position the interface connector 95 outside of the sterile field.

[452] A check of connections (e.g. an impedance measurement) can be performed, such as using a programmer 600 (e.g. clinician programmer 600').

[453] If paresthesia coverage is desired, an appropriate set of stimulation parameters can be identified, such as parameters beginning at a relatively medium pulse width and frequency range. The stimulation can be delivered, and an increase in amplitude performed while asking the patient questions (e.g. close-ended questions) to identify that patient's perception threshold, a discomfort threshold, and/or an area of coverage (e.g. paresthesia coverage).

[454] In some embodiments, a fluoroscopic, ultrasonic, and/or other image of placement of lead 265 is taken, such as for record-keeping purposes.

[455] If performing a “staged trial”, using a lead 265 to be permanently implanted, interface connector 95 can be detached from lead 265, and anchoring of lead 265 can be performed (e.g. as described hereabove in reference to Fig. 15B). If performing a “temporary trial” using a short term implanted lead (e.g. a temporarily implanted lead 265), the excess portion of lead 265 can be coiled and the lead 265 and interface connector 95 can be covered (e.g. with gauze and dressing).

[456] Anchoring of the lead 265 can be performed as described hereabove in reference to Fig. 15B.

[457] Implantation of implantable device 200 can be performed as described hereabove in reference to Figs. 15C through 15L.

[458] In some embodiments, one or more implantable devices 200 that have been implanted in a patient are explanted. An explantation procedure is described immediately herebelow.

[459] The initial incision and/or lead 265 skin entry site is located. This identification can be performed by palpation, observation of existing surgical artifacts (i.e., previous sites as indicated by scarring), patient interviews, and/or by using fluoroscopy.

[460] A small midline incision is made at this entry site.

[461] Sutures are cut and removed from the anchor elements 221.

[462] Lead 265 is uncoiled, and pulled on the slack end(s) of the lead 265 loop(s), until the distal tip of the lead(s) 265 emerges from the epidural space.

[463] Once the distal end of the lead(s) 265 has been removed from the epidural space, the remaining slack in the lead(s) 265 is pulled in order to dislodge and remove the implantable device 200.

[464] After the implantable device 200 has been removed, all components can be verified to be intact, and that all previously implanted materials are accounted for (e.g. removed or intentionally left in place).

[465] The midline incision is closed and covered with gauze and dressing.

[466] **Referring now to Fig. 16A-B**, a side view of an introducer tool, and a magnified side view of the distal portion of the introducer tool is illustrated, consistent with the present inventive concepts. Implantation tool 65 can comprise an introducer with a tear-away sheath, introducer 6513 shown. Introducer 6513 can include introducer needle 6513a, and tear-away sheath 6513c. Needle 6513a can include a beveled distal end, bevel 6513d shown. Sheath 6513c and needle 6513a comprise lengths such that when needle 6513a is fully inserted into sheath 6513c, bevel 6513d is completely outside of sheath 6513c, but within a relatively small distance, D₁, of the distal end of sheath 6513c, such as to reduce the likelihood of needle 6513a entering a

target location of interest (e.g. the epidural space), without the distal end of sheath 6513c also entering that target location. In some embodiments, D1 comprises a length of no more than 3mm, or no more than 2mm.

[467] Referring now to Figs. 17A-C, views of an external device and a charging device are illustrated, consistent with the present inventive concepts. Fig. 17A is a perspective view of charger 61, and Fig. 17B is an exploded view of charger 61. Fig. 17C is a view of an external device 500 positioned just above a charging position within charger 61. As described hereabove in reference to Fig. 1, one or more external devices 500 can comprise an integrated power supply 570 comprising one or more rechargeable elements, such as a rechargeable battery. Each external device 500 can be configured to engage a charging device, charger 61 shown, such that power supply 570 can be recharged. Charger 61 can be configured to attach to standard wall AC power, and/or it can include an integral battery (e.g. a replaceable or rechargeable battery).

[468] Charger 61 comprises housing 6110, which includes top housing 6110a and bottom housing 6110b. One or more contacts, contacts 6120, can be positioned on housing 6110a and can be configured to electrically connect to mating contacts of external device 500, contacts 571, as shown in Fig. 17C. Contacts 6120 are connected to energy-providing circuitry of charger 61 (not shown), and contacts 571 are connected to charging circuitry of power supply 570 of external device 500.

[469] Charger 61 can comprise one or more features to maintain the position of an external device 500 during charging. For example, charger 61 can comprise flange 6112 which is configured to frictionally engage the perimeter of each external device 500. Alternatively or additionally, charger 61 can comprise recess 6111 which is configured to slidably receive a mating projection of each external device 500, projection 512, each shown in Fig. 17C. In some embodiments, charger 61 comprises two or more recesses 6111 and external device 500 comprises two or more mating projections 512. In some embodiments, one or more recesses 6111 of charger 61 comprises a projection, and one or more projections 512 of external device 500 comprises a mating recess. Recess 6111 and/ mating projection 512 are positioned and include a geometry (e.g. the “N” shape shown or other geometry that allows a single rotational orientation of device 500) such that when external device 500 is inserted into charger 61, contacts 6120 make contact with the corresponding contacts 571 (e.g. the contacts are vertically aligned when projection 512 mates with recess 6111).

[470] In some embodiments, charger 61 comprises one or more magnets, magnet 6113, which can be configured to magnetically attract a magnetic material of each external device 500, such as ferrite disk 557 described hereabove in reference to Fig. 10. In some embodiments,

charger 61 comprises one or more magnets 6113 as well as one or more other external device 500 retention features (e.g. flange 6112 and/or recesses 6111 described hereabove).

Alternatively or additionally, external device 500 can comprise mating magnets or other magnetic material (e.g. magnetic material which provides correct orientation of contacts 6120 and 571 as described hereabove).

[471] Contacts 6120 and 571 can comprise mating conductive surfaces which make sufficient electrical contact when an external device 500 is properly positioned in a charger 61. Alternatively, the pair of charging contacts can comprise a standard micro or mini USB port and plug.

[472] Charger 61 can comprise one or more features which cause external device 500 to tend to remain properly engaged with charger 61, once in place. For example, flange 6112 (which mates with housing 510) and/or magnets 6113 (which attract ferrite disk 557 or other magnetic material of device 500) can be configured to work singly or in combination to cause external device 500 to remain in place.

[473] In some embodiments, charger 61 comprises a memory module 6114 which includes electronic memory and circuitry configured to record and process information related to charge and/or discharge cycles of one or more external devices 500, as well as record other characteristics, each of which can be used to predict power supply 570 condition, expected longevity and the like, which can be presented to a user or manufacturer of external device 500 (e.g. via a user interface of charger 61, not shown, or other user interface of apparatus 10).

[474] In some embodiments, charger 61 comprises an interface module 6115 which is configured to interface with a communication network via a wired or wireless communication, such as a communication network selected from the group consisting of: cellular service; the Internet; LAN; WAN; computer network; and combinations thereof. In these embodiments, communication with an external device 500 attached to charger 61 can be performed remotely, such as by a clinician of the patient or a manufacturer of external device 500. The communication can include downloading of apparatus 10 use information, and/or programming of external device 500 or other apparatus 10 component.

[475] In some embodiments, charger 61 comprises a light, display, or other user output component, indicator 6121 shown. Indicator 6121 can comprise a ring-geometry, such as a ring that is positioned between two portions of housing 6110 as shown in Fig. 17B. Indicator 6121 can comprise one or more light emitting diodes or other visual indicators, (“LEDs” herein), such as one or more LEDs that change color (e.g. from yellow to orange to green) to indicate different

charging status of the power supply 570 of the external device 500 being charged. The LEDs can be positioned under a ring of translucent plastic or other translucent material.

[476] In some embodiments, charger 61 provides charging energy to power supply 570 of external device 500 via wireless transfer of energy (e.g. avoiding the need for contacts 6120 and 571). For example, charger 61 and external device 500 can comprise corresponding mating inductive coils for energy transfer.

[477] **Referring additionally to Fig. 17D**, a schematic of external device 500 charging circuitry is illustrated, consistent with the present inventive concepts. External device 500 can be configured to prevent corrosion of contacts 571. External device 500 (e.g. controller 550 and/or power supply 570) can include circuitry (e.g. switching circuitry) configured as a passivation module (e.g. to prevent or at least reduce corrosion on contacts 571, such as in the presence of salts, sweat, and the like). When an external device 500 is not operably connected to charger 61 (e.g. as detected by external device 500), external device 500 removes the voltage from being present at contacts 571. As shown in Fig. 17D, when external device 500 is not operably connected to charger 61, Q1 (e.g. a transistor) acts as an open switch, and power supply 570 is disconnected from pins 571. When external device 500 is operably connected to charger 61, a voltage is sent on the “detect” pin, which closes Q2, which in turn closes Q1, connecting power supply 570 to pins 571 (which in turn is connected to charger 61 pins 6120, such as to charge power supply 570).

[478] In some embodiments, external device 500 is configured to detect an operable (e.g. successful) connection to charger 61. In these embodiments, when such a connection is detected, external device 500 can be configured to shut down (i.e. prevent or at least limit) one or more transmissions to an implantable device 200 (e.g. a transmission comprising transmission of power and/or data to an implantable device 200), such as when external device 500 enters a “sleep state” when attached to a charger 61, to prevent undesired load on power supply 570 while charging.

[479] Dual levels of power supply 570 protection can be included, such as protection circuitry including active circuitry and/or passive components (e.g. a thermal or other resettable fuse). In some embodiments, power supply 570 includes a battery including protective circuitry. In some embodiments, external device 500 and/or charger 61 includes circuitry to protect power supply 570.

[480] **Referring now to Fig. 18**, a schematic view of a portion of electronic assembly 255 is illustrated, consistent with the present inventive concepts. Electronic assembly 255 comprises portion 255a which includes various components configured to safely and effectively deliver

stimulation energy to tissue (e.g. via stimulation elements 260). Electronic assembly portion 255a includes address-mapped registers that can be written directly from external device 500 via a forward-telemetry (FTEL) link, but bandwidth constraints of that link could limit the rate at which stimulation delivered by implantable device 200 can occur. To overcome this limitation, a digital control structure known as the Stimulation Control Table (SCT) can be used. Electronic assembly portion 255a of implantable device 200 can include a configurable state machine (Stimulation Control Table – SCT) that can execute autonomously (e.g. within pre-determined limits) to generate stimulation pulses and maintain fine grained (e.g. precise) stimulation control of timing and/or amplitude. Being a state machine (as opposed to a microcontroller) the SCT does not perform computations or make decisions, and therefore its behavior is deterministic and highly predictable. Specifically, the following types of parameters can be encoded in the registers and parameters that drive the state table: pulse width; inter-phase gap; and/or inter-pulse gap. The SCT can also specify the amplitude of stimulation from a register. Alternatively, the amplitude (and/or timing) can be specified directly in the sequence or it can be provided dynamically.

[481] Layered above a pulse or series of pulses, a “loop” can be used to play a sequence repeatedly (e.g. the SCT includes 4 nested loop levels). The loops also allow for long sequences of pulses to be played (e.g. delivered) without involvement from external device 500 (thereby reducing telemetry traffic, such as to improve EMI and/or power efficiency of apparatus 10). With a local clock source, the SCT can execute commands without any external involvement (e.g. transmissions from external device 500) for significant periods of time (depending on the stability and accuracy of the clocks of external device 500 and implantable device 200). Loops can also be used to implement trains of stimulation pulses and/or bursts of stimulation pulses.

[482] The SCT can include the ability to implement a 1-level sub-routine. The sub-routine minimizes the usage of program memory (allowing the electronic circuitry to be smaller). Additionally or alternatively, the sub-routine can allow for complex and/or arbitrary stimulation waveforms to be implemented.

[483] The stimulation amplitude, loop counters and intervals (which can be used for pulse width, inter-pulse gap, and the like) can be modified by external device 500 at time of stimulation energy delivery and can be used by the SCT when a subsequent start command is received. In this manner, significant change can be made to the stimulation patterns with minimal telemetry information needing to be transmitted from external device 500 to implantable device 200. The SCT can trigger measurements. The SCT can check status registers (whose contents can be set from comparisons between registers and/or measured quantities) and relay

results to the external device 500 and/or autonomously take action as a result of the checking performed by the SCT. The SCT can halt stimulation if errors are detected.

[484] Referring additionally to Fig. 19 a block diagram of a TTAP system is illustrated, consistent with the present inventive concepts. External device 500 can include a digital control structure, a Telemetry Timing Aware Peripheral, or “TTAP” herein. The TTAP works with the SCT described hereabove to ensure reliable and efficient operation of apparatus 10. The TTAP starts the sequence of stored instructions in the SCT program table, where the SCT executes the sequence once and waits for further TTAP start commands.

[485] In this manner, the autonomous execution time can be controlled while starting a new sequence with minimal telemetry. The TTAP can turn the external device 500 on and off to coincide with the stimulation pulses delivered by implantable device 200, within a sequence, such as to ensure optimal and sufficient power delivery. The TTAP can use a crystal-controlled clock source, and can provide the master time base for apparatus 10. The rate at which the TTAP issues start commands to the SCT can determine the overall stimulation rate.

[486] In some embodiments, the stimulation control table can store multiple sets of instructions that can be invoked by the TTAP. Each time the TTAP issues a start command to the SCT, the TTAP can request to start the previous set of instructions or a start a new set (generally stored at a different starting address). Such a configuration can be implemented by implantable device 200 to efficiently execute complex waveforms (for instance, combining a train stimulation waveform with a traditional tonic waveform).

[487] Referring now to Fig. 20A, a schematic view of a power delivery and consumption arrangement of a stimulation apparatus is illustrated, consistent with the present inventive concepts. Apparatus 10 of the present inventive concepts can include arrangement 11 which can be configured to enhance reliability of apparatus 10 (e.g. enhance reliability of therapy delivery and/or other functionality). Arrangement 11 can be performed by and/or can include one or more components positioned within external device 500, implantable device 200, and/or another component of apparatus 10. In some embodiments, arrangement 11 can be configured to reduce power consumption (e.g. enhance battery or other power supply 570 life of an external device 500). In some embodiments, an implantable device 200 receives wireless power from an external device 500, and arrangement 11 is configured to both enhance reliability (e.g. enhance reliability of therapy delivery by the implantable device 200) and reduce power consumption (e.g. enhance battery life of the external device 500). For example, arrangement 11 can be configured to avoid time periods in which insufficient power is received by an implantable device 200. Simultaneously, arrangement 11 can include one or more algorithms, algorithm 15

(e.g. one or more “optimization” algorithms), which routinely (e.g. continuously and/or intermittently) and/or intelligently adapt to the physical environment of one or more components of apparatus 10, while external device 500 provides power above a minimum threshold required for reliable operation (e.g. reliable stimulation provided to the patient via implantable device 200). These algorithms 15 can also adapt to diverse therapy configurations (e.g. diverse amounts of stimulation energy being delivered) and/or adapt to various implantable device 200 state conditions, and the algorithms 15 can manage transitions in these configurations and conditions.

[488] Each implantable device 200 is desired to be relatively small, and therefore can have limited energy storage capacity (e.g. limited energy storage capacity of energy storage assembly 270). When there is a change in power transfer (e.g. a sudden change that can occur with patient motion) and/or there is a change in power consumption (e.g. due to a change in delivery of stimulation energy), arrangement 11, via algorithm 15, can be configured to rapidly adapt so that power delivery from an external device 500 to the implantable device 200 remains sufficient for safe and reliable operation.

[489] Apparatus 10 can include multiple mechanisms for adjusting power delivery between an external device 500 and an implantable device 200. For example, a first mechanism can adjust the amplitude of power transmitted by external device 500 to change the output power of the transmission signal (e.g. an RF signal). Alternatively or additionally, a second mechanism can turn the power transmitted by external device 500 on and off, such as via a duty cycle that includes a ratio of “on time” versus “off time” that is set and/or adjusted by an algorithm 15 (e.g. an optimization algorithm of arrangement 11, such as an algorithm 15 of external device 500). Power can be wasted if energy stored on implantable device 200 reaches a maximum value (e.g. where further charging can’t occur) and external device 500 continues to deliver power. This energy storage maximum can be limited by an acceptable input voltage of a rectifier (e.g. rectifier 232) of implantable device 200, such as when the rectifier is operating as a charge pump, providing a voltage multiplication of an input voltage of an antenna (e.g. antenna 240) of implantable device 200. Implantable device 200 can include other electronic componentry that limits a maximum voltage for energy storage (e.g. the circuitry includes a voltage clamp that prevents an excessive voltage from damaging an electronic component).

[490] Arrangement 11 can be configured to perform duty cycle modulation of power transferred by an external device 500 based on an amplifier of external device 500 being more efficient when charging at particular power levels (e.g. high-power levels) that do not saturate circuitry of implantable device 200 and/or do not cause reduced efficiency by exceeding an optimal input voltage of a rectifier 232 of implantable device 200. As described hereabove,

power can be delivered in bursts via duty cycle modulation which can deliver power before and after stimulation pulses (e.g. in a symmetric pattern). Power delivery before stimulation can prevent a significant voltage drop (e.g. of energy storage assembly 270) when implantable device 200 transitions from operating at a quiescent current to a state in which device 200 is delivering stimulation energy to tissue. If sufficient energy is available, boosting circuitry of implantable device 200 can operate with a minimum conversion ratio, which increases efficiency and maximizes the instantaneous power that implantable device 200 can deliver (e.g. power related to delivering stimulation energy to tissue). Power delivery to device 200 after stimulation delivery by device 200 can replenish energy used during stimulation, and it can reduce impact of disturbances in power transfer. Duty cycle modulation can be applicable to idle (e.g. no stimulation) modes and/or lower frequency stimulation modes (e.g. stimulation below approximately 1.5kHz or below 1kHz) of implantable device 200. When varying power transfer with duty cycle, an optimization algorithm 15 of arrangement 11 can measure stored energy in implant 200 (e.g. stored in energy storage assembly 270), for example a measurement performed once every stimulation period (e.g. a period of time in which one or more forms of stimulation energy is delivered), and algorithm 15 can adjust the duty cycle based on an analysis of energy requirements for that stimulation period. Energy measurements (e.g. voltage measurements) can be taken (e.g. immediately) prior to a first stimulation pulse in the stimulation period, a point in which the stored energy can be high. To measure a target energy level effectively, a target voltage of energy storage assembly 270 can be set slightly below the maximum allowed value. An optimization algorithm 15 can determine a target (maximum) value of energy storage by increasing (or maximizing) the duty cycle for a (short) time period, and subsequently measuring the energy level. Alternatively or additionally, the energy level can be occasionally increased over time until a constant error is observed (e.g. a maximum has been achieved), which also indicates a limit has been reached. The target energy level used by algorithm 15 can then be adjusted slightly below the maximum thereby allowing optimized energy storage with the described control loop (also referred to as “tracking loop” or “feedback loop” herein). During optimization, the duty cycle at each stimulation cycle can be fed to a lowpass digital filter (e.g. a filter of controller 550) with a time constant that is much slower than the stimulation rate, and the output of this filter can be sampled after several time constants. The filtered value is the average duty cycle during the sampling period. If the average duty cycle is too high, then the output power of the transmitter 530 of external device 500 can be increased. If the average duty cycle is too low, then the output power of the transmitter 530 of external device 500 can be decreased. Controlling the average duty cycle can allow the power transmitter 530 to operate at an

optimized point, and it can allow a feedback loop of arrangement 11 to quickly raise duty cycle in response to a disturbance in power.

[491] Arrangement 11 can utilize duty cycle modulation when there are multiple stimulation pulses delivered in a stimulation period. The power transferred from external device 500 to implantable device 200 can be allocated based on energy of stimulation pulses, as well as when the pulses occur in the stimulation period. With multiple stimulation pulses, the periodic measurement of available energy in implantable device 200 can be performed immediately prior to the stimulation pulse delivering the greatest energy. In other words, if a stimulation period consists of multiple pulses, a timing of a stimulation period can be defined such that the largest energy pulse is the first pulse.

[492] Arrangement 11 of Fig. 20A demonstrates the available energy over time, as power is transmitted and used by implantable device 200. As described above, power transmission from external device 500 is represented by two parameters, the amplitude of the transmission signal, and the duty cycle of transmission. Power consumption by each implantable device 200 comprises: energy delivered during stimulation; energy delivered performing other functions (e.g. sensing functions, data transmission function, and/or other functions); and/or quiescent energy required by implantable device 200 during minimal operation. Integrating the sum of power used over time determines energy to be stored in implantable device 200, which can have one or more limits as described hereabove. If the energy storage element of assembly 270 is a capacitor or battery, this limit will be reflected as a limit in the voltage as described hereabove. Circuitry of implantable device 200 can also have a maximum operating voltage that limits the energy that can be stored, also as described hereabove.

[493] The power transfer efficiency between an external device 500 and an implantable device 200 represents the ability of external device 500 to provide energy to the implantable device 200 and also represents the quality of the wireless link between the two devices. This efficiency can vary over time (such as with patient motion and/or changes in environment), and the efficiency can be tracked by arrangement 11 such that the implantable device 200 neither loses power (power level decreases to a point below a minimum threshold, such as to cause an interruption in stimulation delivery and/or other implantable device 200 operation), nor is excessively charged (wasting power).

[494] When apparatus 10 reaches a steady state, the duty cycle of power transmission can be stable. For example, over a (repeated) period of time of a control loop (a control loop managed by an optimization algorithm 15 of arrangement 11), the energy transmitted from external device 500 to implantable device 200 can be approximately equal to the sum of: the

energy for therapy (e.g. stimulation energy delivered); the energy required for other functions of implantable device 200; and the quiescent energy requirements of implantable device 200. As a result, the available energy of implantable device 200 will rise and fall the same amount during each time period. Furthermore, the maximum energy will be maintained at a value slightly lower than a limit (e.g. a maximum voltage).

[495] In some embodiments, algorithm 15 only modulates duty cycle of the power transmissions of external device 500. In some embodiments, algorithm 15 modulates both duty cycle and the voltage (e.g. to modulate the average power being transmitted). These modulations can be performed in relation to the current stimulation parameters to be delivered by implantable device 200.

[496] **Referring now to Fig. 20B**, a schematic view of a power delivery and consumption arrangement of a stimulation apparatus is illustrated, consistent with the present inventive concepts. Apparatus 10 of the present inventive concepts can include arrangement 12 which can be configured to enhance reliability of apparatus 10 (e.g. enhance reliability of therapy delivery and/or other functionality). Arrangement 12 can control duty cycle of power transfer between an external device 500 and an implantable device 200. Arrangement 12 can be performed by and/or can include one or more components positioned within external device 500, implantable device 200, and/or another component of apparatus 10. Arrangement 12 includes arrangement 11 as shown, such as arrangement 11 described hereabove in reference to Fig. 20A. Arrangement 12 comprises a “block” (e.g. electronic feedback circuitry) configured to calculate an error (also referred to as a “loop error”) between a setpoint energy level and a measured energy level. The calculated error is provided to a Proportional Integrator (PI) controller (e.g. a PI controller that includes a derivate control) which determines a power transmission duty cycle based on the calculated error. A high proportional path gain allows the control loop of arrangement 12 to respond quickly to disturbances (e.g. power transfer disturbances), thereby providing reliability in implantable device 200 function (e.g. uninterrupted delivery of stimulation energy). Periodically updating the amplitude of power transfer provided by external device 500 can be performed to keep the average duty cycle low, thereby providing a large dynamic range in the duty cycle, such that the proportional path has the required dynamic range to quickly respond to disturbances. The integral path drives the steady state error to zero, thereby providing the optimized resilience to disturbance and optimized efficiency.

[497] The setpoint can be determined dynamically. The error and/or gain can be asymmetric, and it can be adjusted based on previous measurements. Applying the charge time can include allocation over multiple stimulation pulses, each with different amplitudes and/or

timings (e.g. timings such as pulse width timing and/or burst duration timing). Power transfer from external device 500 to implantable device 200 can be periodically adjusted to maintain a duty cycle with the desired dynamic range.

[498] Arrangement 12 can manage significant disturbances by maintaining an energy setpoint that is close to the energy storage limit of energy storage assembly 270. The setpoint can be determined by periodically determining the energy storage limit itself, such as by increasing the duty cycle limit to the maximum for a short period. The energy storage limit can be measured, and the energy setpoint can be set to a value slightly below the measured maximum. If apparatus 10 is in a steady-state mode and power transfer efficiency suddenly increases, the available energy can rise and reach the limit. The measured error will therefore be limited to a value slightly above the setpoint, and, response could be slow causing power to be wasted. This undesired performance can be mitigated by raising the loop gain in response to consecutive negative errors, or with asymmetric gain based on the direction of the error. If power transfer is high and the therapy at a low level (e.g. a low energy delivery level), the minimum duty cycle required for the energy storage measurement can be greater than necessary, and power could be wasted. Conversely, if power transfer is too low, then the average duty cycle can be large, and apparatus 10 may not have the dynamic range to respond to a disturbance. Therefore, it can be desirable to keep the duty cycle of power transmissions from external device 500 within a controlled range, such as a range between approximately 20% and 40%, or between 25% and 33%. This range can be maintained by lowpass filtering the duty cycle with a first order digital filter, and sampling the output every several time-constants, such as every 4 time-constants. The time constant of the digital filter can be approximately the same as the stimulation period or longer than the stimulation period in order to behave as a lowpass filter. If the duty cycle is out of this range, power transfer amplitude can be adjusted accordingly.

[499] Referring now to Fig. 21, a schematic view of a back-telemetry circuit of an implantable device 200 is illustrated, consistent with the present inventive concepts. Controller 250 of implantable device 200 can include back-telemetry module 251 as shown in Fig. 21. Back-telemetry module 251 can be configured to provide dynamic threshold and polarity. Back-telemetry module 251 can include redundant bit encoding.

[500] In some embodiments, controller 250 comprises a dynamic receiver. The dynamic receiver can include a dynamic mechanism for threshold and polarity. The receiver can be configured to determine thresholds of width of pulses, and/or polarity of pulses, dynamically. Controller 250 can receive a series of pulses, and it can decode the pattern dynamically. The

dynamic receiver can determine levels (e.g. 1's and 0's) based on known parameters, such as to calibrate the receiver.

[501] In some embodiments, back-telemetry from implantable device 200 to external device 500 may comprise adjusting an impedance connected to antenna 240 of the implantable device 200. The external device 500 can detect these changes in impedance to recover (i.e. receive and decode) information from implantable device 200. The impedance changes can be performed in short pulses, with information encoded in the length of the pulses. To maintain a balance in timing and in the average amplitude, a data bit can be comprised of both a short and a long pulse. For example, a "0" bit can be represented as a short pulse followed by a long pulse, and a "1" bit could be represented by a long pulse followed by a short pulse. In this way, both the "0" and the "1" bit have an equal length of time and the same average signal level, (i.e. both 0 and 1 have equal high periods and low periods). This combination also offers redundancy to improve error detection and recovery.

[502] In some embodiments, the beginning of a data transmission (e.g. a response) from an implantable device 200 can be represented by a "sync" mark, which can comprise a combination of short and long pulses that would not be possible in a normal data stream. The data sequence can be a fixed length that is known a priori so that the expected number of pulses is known. Knowing the exact number of expected pulses can aid in apparatus 10 detecting and recovering from errors, for example in case a pulse is missed (e.g. not properly detected by external device 500). Additionally, since each data bit is an equal length of time and the data length is known, the exact position of errors in the data can be determined if they occur. Since distortion is most likely at the beginning of a pulse sequence, implantable device 200 can be configured to provide a preamble (e.g. a sequence of dummy data) that precedes the actual data and the sequence can be decoded by external device 500 in reverse order, from the final pulse towards the first. If the data length is known, external device 500 can stop decoding once all the data is recovered, ignoring the possibly distorted pulses at the start of the sequence.

[503] In some embodiments, external device 500 can recover these pulses and convert them to a digital signal using an analog filter with a comparator included in external device 500 (e.g. included in controller 550). If the encoding described above is used to maintain a constant average signal regardless of the content of the data, then the comparator can compare the average to the envelope of the recovered signal to perform this conversion. Since this signal is detected from an impedance change, it is possible that the pulses will be recovered as either increases in the signal level or decreases in the signal level depending on the characteristics of the link, such as transmitted power or coupling. External device 500 can dynamically determine the polarity of

the pulses by reading a known value received from the implantable device 200, decoding the response, and adjusting the polarity based on the result (e.g. calibrating external device 500 based on the result). Additionally, it is possible that the signal will be distorted when recovered by external device 500, and this distortion may also change based on the transmitted power level and coupling. This distortion effect can result in the durations of the pulses changing as the device operates normally. To correctly recover this data, the external device 500 can accumulate the durations of all the pulses in the response and divide by the number of pulses, to determine the average pulse width. Then, external device 500 can use this average pulse width to differentiate between short and long pulses. By doing this computation, external device 500 can dynamically adjust the decoding threshold to achieve optimized recovery of the data.

[504] In the illustrations described herebelow in reference to **Figs. 22A-F**, various arrangements of one or more leads 265 including sets of stimulation elements 260 (e.g. electrodes) are shown. In the figures, the boxes labeled I_S represent series impedance related to the associated stimulation element 260. The boxes labeled I_T represent tissue impedance between the two adjacent stimulation elements 260.

[505] Referring now to **Fig. 22A**, a schematic view of an implantable device 200 comprising two leads 265 is illustrated, consistent with the present inventive concepts. Each lead 265 comprises multiple stimulation elements 260 (eight shown for each lead 265). In some embodiments, implantable system 20 is configured without a monopolar return path, such as when stimulation energy is delivered in a bipolar mode between pairs of stimulation elements 260 (e.g. without housing 210 of an implantable device 200 functioning as a current return path). During stimulation, certain stimulation elements 260 (e.g. electrodes) are configured as anodes, and certain stimulation elements 260 are configured as cathodes. Implantable device 200 comprises a current source that is connected to the cathodes while the anodes are connected to a system ground of implantable device 200 (e.g. to complete the electrical stimulation circuit). It is of interest to know the network of impedances between the various stimulation elements 260 (e.g. between the cathodes and the anodes). These impedances can be determined if the impedance of each individual stimulation element 260 is known. In order to measure individual stimulation element 260 impedances (e.g. electrode impedance), a “pseudo-monopolar” connection can be made, as described herebelow in reference to Fig. 22B.

[506] Referring now to **Fig. 22B**, a schematic view of an implantable device 200 including multiple stimulation elements 260 configured to perform an impedance measurement associated with a first stimulation element 260' is illustrated, consistent with the present inventive concepts. Implantable device 200 and its stimulation elements 260 have been implanted in a patient, and

electrical pathways in the tissue between the elements 260 are shown. In a first step, stimulation element 260' is configured as a cathode, and all other "remaining" stimulation elements 260 (e.g. in the same lead 265) are assigned as anodes, where these remaining stimulation elements 260 are connected in parallel to the system ground. In doing so, the effect of individual remaining stimulation elements 260 shown including within the box "B" is minimized (e.g. allowing a "pseudo-monopolar" calculation to be made). A current source (e.g. of controller 250) drives a current pulse through this network and the resulting voltage pulse is measured at stimulation element 260' with respect to system ground. By sampling the voltage pulse close to the pulse rising edge and using Ohm's law, an approximation of impedance of stimulation element 260' is obtained.

[507] Similarly, the impedance of all other stimulation elements 260 is measured. A similar process can be repeated for additional sets of stimulation elements 260 (e.g. additional stimulation elements 260 included on additional leads 265).

[508] The stimulation element 260 impedance (e.g. electrode impedance) measured using this method is an "upper bound" on the actual impedance value. This bounded value is desirable for calculating current source compliance voltage requirements.

[509] **Referring now to Fig. 22C**, a schematic view of an implantable device 200 including multiple stimulation elements 260 configured to perform a check for undesired shorts is illustrated, consistent with the present inventive concepts. In the embodiment of Fig. 22C, an undesired short exists between stimulation element 260' and stimulation element 260'' as shown. When a current source (e.g. of controller 250) delivers a current pulse to element 260', the voltage developed at stimulation element 260' with respect to system ground is close to zero (e.g. below a threshold) as the path of least resistance is from element 260' to element 260'' to system ground. This current pulse results in a very small impedance measurement on stimulation element 260' (e.g. as described hereabove in reference to Figs. 22A-B). Similarly, when measuring impedance of stimulation element 260'', a very small impedance value is also measured. These two impedance measurements are indicative of a short between the two elements 260' and 260''. In general, if such an impedance measurement results in a small value at any stimulation element 260, it is indicative that the stimulation element 260 is shorted to another stimulation element 260 (e.g. another element 260 of the same lead 265). Such a check for shorts can be performed during a manufacturing process, or at any time (e.g. just prior to and/or after implantable device 200 is implanted in the patient).

[510] **Referring now to Fig. 22D**, a schematic view of an implantable device 200 including multiple stimulation elements 260 configured to perform a check for undesired shorts is

illustrated, consistent with the present inventive concepts. In the embodiment of Fig. 22D, an undesired short exists between stimulation element 260' and stimulation element 260'' as shown. A multiplexor, such as an analog multiplexor, MUX1 shown, can be used to attach any and/or all of stimulation elements 260 to ground (sequentially and/or simultaneously). To determine if a stimulation element 260 (e.g. stimulation element 260' shown) is shorted to any other stimulation element 260, a current source (e.g. of controller 250) is connected to stimulation element 260' and the resulting voltage is measured on all other stimulation elements 260. If there is no short (or other electrical connection path) between stimulation element 260' and all other elements 260, then no voltage shall be observed at those elements 260 (e.g. with respect to system ground). If a voltage is observed (e.g. a voltage above a threshold is observed), then a short between element 260' and some other element 260 is determined to be present by implantable device 200. In the illustration, a pulse generated by a current source connected to stimulation element 260' is observed on all other stimulation elements 260 (e.g. electrodes) due to a short between stimulation element 260' and 260''. During use, such an observed pulse is indicative that stimulation element 260' is shorted to some other stimulation element 260.

[511] Referring now to Fig. 22E, a schematic view of an implantable device 200 including multiple stimulation elements 260 configured to perform a check for undesired open circuits is illustrated, consistent with the present inventive concepts. In the embodiment of Fig. 22E, an undesired open circuit exists at stimulation element 260' as shown. In a diagnostic test, a current source (e.g. of controller 250) attempts to deliver current through a stimulation element 260. If an open circuit is present, the voltage observed on that stimulation element 260 would be high. The high voltage is interpreted as a high impedance per the impedance measurement test described hereabove in reference to Fig. 22A-B.

[512] Referring now to Fig. 22F, a schematic view of an implantable device 200 including multiple stimulation elements 260 configured to measure individual stimulation element impedance is illustrated, consistent with the present inventive concepts. Fig. 22F illustrates an example electrical connection used to perform an impedance measurement method. In this configuration, a current source is connected to one stimulation element, stimulation element 260' shown, and the return path is completed using another stimulation element, stimulation element 260'' shown. A voltage pulse resulting due to a current pulse generated by the current source is measured at stimulation element 260'. By sampling the voltage pulse close to the rising edge of the pulse, an estimate of the sum of individual impedances R_0 and R_1 is obtained. If R_{01} indicates the sum, then $R_{01} = R_0 + R_1$. Similarly, estimates for two other pairs can be obtained. For example, $R_{12} = R_1 + R_2$; and $R_{02} = R_0 + R_2$. These equations can be solved simultaneously

to calculate the unknown impedance values: R_0 , R_1 and R_2 . Similarly, all the remaining individual impedances can be calculated. Alternatively or additionally, the impedance measurement method described in Fig. 22A-B can be used as a pre-processing step to find out if there are open electrodes (stimulation elements 260) in the lead 265, such that these elements can be omitted from the set of equations to be solved simultaneously. This method can limit inaccuracies that may result due to including open electrodes in the set of measurements. In some embodiments, estimates of several pairs can be analyzed together and the large set of equations solved using linear algebraic methods.

[513] Referring now to Fig. 23, a graph of an amplitude modulation scheme is illustrated, consistent with the present inventive concepts. Transmissions between an external device 500 and one or more implantable devices 200 can comprise a modulated transmission signal, such as an amplitude modulated transmission signal as shown in Fig. 23. In some embodiments, the modulation depth is relatively “shallow” (e.g. a modulation depth less than 20%, or less than 5%). Such shallow modulation depths provide numerous advantages, such as reduced emissions (e.g. for regulatory compliance), improved efficiency, and/or reduced instantaneous power transfer. External device 500 can comprise an electronic potentiometer (e.g. controller 550 comprises the electronic potentiometer) that allows adjustment of the modulation depth (e.g. by adjusting the input voltage driving a gate of an amplifier providing the transmission signal, such as an amplifier which is operating at saturation). In some embodiments, the electronic potentiometer is adjusted in manufacturing of external device 500, such as using a set of values corresponding to a power amplifier setting. Alternatively or additionally, the electronic potentiometer can be adjusted in use (e.g. in the clinical setting). For example, controller 550 can include firmware that determines a desired modulation depth, such as to optimize efficiency of transmissions without sacrificing reliability of transmissions. Such adjustment in the clinical setting can minimize communication errors, such as when the associated implantable device 200 has been implanted relatively deep under the surface of the skin, such as when a component of an external device 500 (e.g. ferrite or other component) and/or implantable device 200 has been damaged or is otherwise compromised.

[514] Referring now to Figs. 24A-B, top views of an external device 500 positioned on a patient in a first orientation, and a second orientation, respectively, is illustrated, consistent with the present inventive concepts. In Fig. 24A, external device 500 is positioned in a first orientation, on a patient’s skin above an implantable device 200 that has been implanted in the patient, and transmissions (e.g. power and/or data transmissions) between the two devices can occur successfully and efficiently. In some embodiments, external antenna 540 of external

device 500 is positioned at a skin location that is relatively centered, “concentric” herein, with implantable antenna 240 of implantable device 200. In these embodiments, antennas 540 and 240 can be positioned within housings 510 and 210 respectively, such that positioning housing 510 at a skin location that is relatively centered with the position of housing 210, will in turn, properly position antenna 540 with antenna 240 (e.g. to optimize transmissions between the antennas). External device 500 can be configured to be positioned in a second orientation, different than the first orientation, without reducing transmission quality between devices 500 and 200. For example, external device 500 can be configured to be rotated but similarly concentrically positioned over implantable device 200, such as when rotated 180° as shown in Fig. 24B, without adversely affecting transmission quality. Apparatus 10 can be configured to perform the transmissions relatively equally in different orientations, such as when efficiency of transmissions from external device 500 to implantable device 200, from implantable device 200 to external device 500, and both, are relatively unaffected by the different orientations (e.g. different rotational orientations of device 500, with antenna 540 and/or housing 510 proximate the patient’s skin surface and relatively centered over antenna 240 and/or housing 210). Avoiding the need to achieve a particular orientation (e.g. a particular rotational placement of external device 500 on the patient’s skin), greatly simplifies attachment of external device 500 to the patient’s skin by a user (e.g. by the patient).

[515] For example, antennas 240 and/or 540 can comprise a construction, and each can be oriented in implantable device 200 and/or external device 500, respectively, in a way that minimizes the impact of a particular orientation of external device 500 to an implanted implantable device 200. In some embodiments, antennas 240 and/or 540 comprise loop antennas, such as rectangular loop antennas. In some embodiments, the ratio of the size of external antenna 540 compared to the size of implantable antenna 240 is relatively high, such that the impact of orientation variations is minimized, such as a ratio of at least 2:1, 4:1, and/or 6:1.

[516] Referring now to Fig. 25A, a schematic view of a reconfigurable stimulation block (RSB) portion 255b of electronic assembly 255 of implantable device 200 is illustrated, consistent with the present inventive concepts. RSB 255b can comprise one or more current sources, such as a high-side current source and a low-side current source. In the embodiment shown in Fig. 25A, there is only one (high-side) current source, and the current return path is to ground through the closing of switch S_L shown, which is connected to VB (versus a return path through a low-side current source). In active charge recovery (bipolar stimulation), current direction is reversed by changing the MUXA and MUXB settings. For example, during a

stimulation phase, E1 is connected to VA and E0 is connected to VB, whereas during a recovery phase, E1 is connected to VB and E0 is connected to VA. Current source and ground switch settings remain the same in both phases. As compared to an arrangement with both a high-side and a low-side current source, low-side current source and high-side supply switches have been eliminated.

[517] Referring now to Fig. 25B, a diagram of a control input sequence is illustrated, consistent with the present inventive concepts. Use of the control signals of Fig. 25A are shown in Fig. 25B. Current flows through switch S_D when any bits of 'rsbx_isrc_sel<3:0>' is asserted and when 'rsbx_gate_reg' (sync signal) is not asserted. This time period needs to be small in order to minimize the power lost during the "dump phase" (e.g. when current is diverted through switch S_D and resistor R_D shown). The RSB 225b circuitry is designed to be operated with this time period being as small as $1\mu\text{s}$. 'Rsbx_swselb' & 'rsbx_ss_sel' can be asserted at the same time as 'rsbx_isrc_sel' in order to shorten stimulation setup time. As show in Fig. 25B, these signals need not be de-asserted in the region between the two phases of the stimulation.

[518] In some embodiments, a DC blocking capacitor is included in RSB 225b, capacitor C_{DC} . In the embodiment shown in Fig. 25A, the DC-blocking capacitor C_{DC} is not included, instead each stimulation element 260 (e.g. electrode) has a DC-blocking capacitor between each MUXA/B output terminal and the corresponding stimulation element 260 (tissue connection). There can be 16 DC-blocking capacitors (e.g. for spinal cord stimulation); and these capacitors can be shared between all RSB 255b's. A single set of discharge switches (e.g. transistors configured as switches) can be connected between the VA and VB nodes.

[519] Referring additionally to Fig. 25C, a schematic view of another portion of electronic assembly 255 is illustrated, portion 255c, consistent with the present inventive concepts. Given that the stimulation current path contains switched capacitive elements, both in the interface between stimulation elements 260 and tissue, and in the form of DC-blocking capacitors, it is possible for chip nodes (e.g. connection points of an integrated circuit) to go below the ground rail (e.g. below a ground level of voltage associated with the integrated circuit) as follows. During the stimulation phase, a first terminal of the series capacitor string is charged positively with respect to the other terminal of the capacitor. During the recovery phase, the first terminal is connected to ground and thus the other terminal of the capacitor is charged negatively with respect to the first voltage (e.g. the voltage of the second terminal can go below ground, which can result in undesired current flow). This configuration can forward-bias ESD-protection and parasitic bulk diodes of the output circuits, and it can cause the recovery current to be uncontrolled. This lack of control, in turn, can cause charge-balance problems if the

external DC-blocking capacitors are not included, and/or it can result in inaccurate stimulation current being delivered. In some embodiments, these issues are solved by adding series resistors between the ground switch and stimulation outputs during the recovery phase. As current flows through these resistors they create a voltage drop, which raises the otherwise-negative terminal to a desired level above ground potential. Typically, soft switches (e.g. transistors T₀ through T₁₁ shown) are enabled during the start of the recovery phase (e.g. to avoid undesired current flow, such as undesired current flow in the integrated circuit), and then switched out (e.g. disabled) as the capacitor(s) discharge, to avoid loss in stimulation compliance. Example architecture of the soft switches, and example resistance values, are listed below.

Soft Switch (Transistor)	rsbx_ss_sel	Resistance Value
	000000000000	-
T ₀	000000000001	200
T ₁	000000000010	200
T ₁	000000000100	200
T ₃	000000001000	200
T ₄	000000010000	500
T ₅	000000100000	800
T ₆	000001000000	1.5k
T ₇	000010000000	2.7k
T ₈	000100000000	5.4k
T ₀₉	001000000000	8k
T ₁₀	010000000000	15k
T ₁₁	100000000000	50k

[520] Referring now to Fig. 26A-C, schematic views of a test fixture arrangement for testing electronic assembly 255 is illustrated, consistent with the present inventive concepts. Test fixture 97 is constructed and arranged to perform one or more tests on electronic assembly 255 of an implantable device 200. In a first embodiment, as described in reference to Fig. 26A, test fixture 97 is configured to perform a test on electronic assembly 255 when implantable device 200 is in a partially assembled state, when electrical access points on electronic assembly 255 are accessible to test fixture 97. In an alternative or additionally second embodiment, as described in reference to Figs. 26B-C, test fixture 97 can be configured to perform a test on an

electronic assembly 255 by connecting with one or more stimulation elements 260 (e.g. electrodes) and/or other stimulation energy-providing electrical access points outside of housing 210. In other words, test fixture 97 can be configured to perform a test on electronic assembly 255 when implantable device 200 is in a fully manufactured state (e.g. in a state ready for shipment to a customer and including a pre-attached lead 265 and/or an attachable lead 265). In the fully manufactured state, a ground pathway of electronic assembly 255 may not be available to perform a test in which electronic assembly 255 and test fixture 97 share a common ground.

[521] Referring now to Fig. 26A, as described hereabove, test fixture 97 can be configured to test electronic assembly 255 while implantable device 200 is in a partially assembled state. Test fixture 97 includes connection point 9701a which is shown having been attached (e.g. by an employee of the manufacturer of electronic assembly 255) to electrical connection point 256a of electronic assembly 255, and connection point 9702 is shown similarly having been attached to electrical connection point 257 of electronic assembly 255 (e.g. creating a common ground between electronic assembly 255 and test fixture 97). Electrical connection point 256a is part of a first electrical signal pathway (e.g. wire or trace) that is configured to deliver stimulation energy to a first stimulation element 260a (e.g. an electrode, not shown). Electrical connection point 256a can be positioned “downstream”, as shown, of a capacitor in series with the first electrical signal pathway, capacitor C1, such that test fixture 97 can test the leakage current of capacitor C1. For example, during a test of the first signal pathway, an ASIC of electronic assembly 255 connects the upstream side of capacitor C1 to a switch, switch S1, by activating a multiplexor, MUX 1, to make the specific connection between C1 and S1. The ASIC also closes switch S1 such that the upstream side of capacitor C1 electrically connects to a ground pathway of electronic assembly 255, as shown. During this test of the first signal pathway, test fixture 97 electrically connects connection point 9701a to an ammeter, M1, which is attached to a voltage supply, DC voltage supply V_{CC} shown. In this first connection configuration shown, ammeter M1 measures any leakage current of capacitor C1. Subsequent tests of all remaining capacitors C2 thru C_N can be performed. Connection points 9701b thru 9701n of test fixture 97 are attached to corresponding connection points 256b thru 256n of electronic assembly 255 (e.g. connections which are made singly or collectively prior to each test). Sequential tests of each capacitor C2 thru C_N can be performed when MUX 1 sequentially connects each capacitor C2 thru C_N , to switch S1 (e.g. which is closed and connected to the ground pathway of assembly 255), and a multiplexor of test fixture 97, MUX 2, simultaneously and respectively connects each connection point 9702b thru 9702n to voltage supply V_{CC} . In some embodiments, electronic assembly 255 is configured to provide stimulation energy to multiple stimulation

elements 260 (e.g. electrodes), such as 4, 6, 8, 12, and/or 16 electrodes, such as when electronic assembly 255 comprises 4, 6, 8, 12, and/or 16 signal pathways, each including a capacitor as shown in Fig. 26A.

[522] Referring now to Fig. 26B, as described hereabove, test fixture 97 can be configured to test electronic assembly 255 while implantable device 200 is in a fully assembled state (e.g. a state in which a ground pathway of electronic assembly 255 may not be available to connect to test fixture 97). Test fixture 97 includes connection point 9701a which is shown having been attached (e.g. by an employee of the manufacturer of implantable device 200 during a final test, or by a clinician or healthcare provider at a time proximate implantation of implantable device 200) to electrical connection point 256a of electronic assembly 255. Electrical connection point 256a is part (e.g. the end portion) of a first electrical signal pathway (e.g. wire or trace) that is configured to deliver stimulation energy to a first stimulation element 260a (not shown). In some embodiments, electrical connection point 256a comprises a portion of first stimulation element 260a. Electrical connection point 256a can be positioned “downstream”, as shown, of a capacitor in series with the first electrical signal pathway, capacitor C1, such that test fixture 97 can test the leakage current of capacitor C1. For example, during a test of the first signal pathway, an ASIC of electronic assembly 255 connects the upstream side of capacitor C1 to a switch, switch S1, by activating a multiplexor, MUX 1, to make the specific connection between C1 and S1. The ASIC also closes switch S1, which is connected to an input of another multiplexor of electronic assembly 255, MUX 3 as shown. The ASIC activates MUX 3 such that the upstream side of all of the other capacitors, C2 through CN, are connected to switch S1 as shown (e.g. shorted together). During this connection arrangement, MUX 2 of test fixture 97 connects connection point 9701a to ammeter M1. Test fixture 97 further includes another multiplexor, MUX 4 shown, which connects each of connection points 9701b thru 9701n to the ground of test fixture 97 (e.g. shorts each of connection points 9701b thru 9701n to test fixture 97 ground). In this connection scheme of electronic assembly 255 and test fixture 97, voltage provided by supply V_{CC} is presented at the downstream side of capacitor C1. Any leakage current that passes through capacitor C1, subsequently leaks through all of the remaining capacitors C2 thru CN, such that any leakage current measured by ammeter M1 is dominated by the leakage current through capacitor C1. The effective circuit and current path of testing a first stimulation pathway (including capacitor C1), is shown in Fig. 26C. Subsequent tests of all remaining capacitors C2 thru CN can be performed, such as in a similar fashion to that described hereabove in reference to Fig. 26A. For example, in a test of any capacitor CN, MUX 1 connects switch 1 to the upstream side of capacitor CN, and MUX 2 shorts each of the upstream sides of

the remaining capacitors together. Test fixture 97 connects connection point 9701b to ammeter M1, and fixture 97 shorts the remaining connection points 9701 together and to the ground of test fixture 97. In some embodiments, electronic assembly 255 is configured to provide stimulation energy to multiple stimulation elements 260 (e.g. electrodes), such as 4, 6, 8, 12, and/or 16 electrodes, such as when electronic assembly 255 comprises 4, 6, 8, 12, and/or 16 signal pathways, each including a capacitor as shown in Fig. 26B.

[523] Referring now to Fig. 27A-C, a series of views of stimulation waveforms are illustrated, consistent with the present inventive concepts. In Fig. 27A, a tonic stimulation waveform for delivery to a single location (e.g. a single nerve or other continuous tissue volume location) is illustrated. In Fig. 27B, a tonic stimulation waveform for multiple locations (e.g. two to five discrete tissue volume locations capable of being stimulated by multiple stimulation elements 260 of a single lead 265 and/or multiple leads 265) is illustrated. In Fig. 27C, a tonic sequence stimulation waveform is illustrated.

[524] When tonic stimulation is to be provided by apparatus 10 (e.g. to a single location), implantable device 200 can deliver a monophasic pulse as shown in Fig. 27A. When stimulation of a single location is provided, implantable device 200 can perform current steering (e.g. per electrode parameters).

[525] When tonic stimulation of multiple locations is provided by apparatus 10, implantable device 200 can deliver evenly distributed pulses within the stimulation interval.

[526] When tonic sequence stimulation is provided by apparatus 10, implantable device 200 can deliver a sequence of monophasic pulses, such as one pulse for each of multiple locations (e.g. 2, 3, 4, 5, and/or more discrete tissue volume locations stimulated sequentially, and in a repeated arrangement). For tonic sequence stimulation of multiple locations, implantable device 200 can sequence the pulses within the stimulation interval per the pulse width and inter-pulse gaps for each location (e.g. the sequence of pulses is produced based on or otherwise to accommodate the pulse width and inter-pulse gaps intended for each location to be stimulated, such as to avoid overlapping of pulses).

[527] In some embodiments, apparatus 10 includes available programs (e.g. created by apparatus 10 and/or a clinician user of apparatus 10) for stimulating different anatomical locations (e.g. back, leg, and the like, and/or multiple locations within the back, leg, and the like). In some embodiments, apparatus 10 is configured to operate in an “adjacent mode”, in which apparatus 10 delivers a stimulation pulse in a first location, then a second location, and so on, and repeats. Individual cycles of stimulating a sequence of different locations can be

separated by a delay. Alternatively or additionally, apparatus 10 can be configured to operate in an “evenly spaced mode” – where pulses are evenly spaced over a time period.

[528] Referring now to Figs. 28A-G, in some embodiments apparatus 10 and implantable device 200 are configured to perform charge recovery within tissue in a passive arrangement. The charge recovery is performed to maintain a charge balance in the tissue. Implantable device 200 of Fig. 28A can comprise a current source CS_1 , a switch S_1 , a DC blocking capacitor C_{DCB} , and two stimulation elements 260a and 260b, each connected as shown. Current source CS_1 is attached to a power supply 270 that provides voltage V_{DD} , also as shown. The tissue receiving stimulation energy from stimulation elements 260a and 260b (e.g. electrodes), tissue T_1 , can be electrically modeled as a resistor R_2 that is in series with a parallel connection of a capacitor C_1 and a resistor R_1 , as shown.

[529] In Fig. 28B, implantable device 200 is configured in a stimulation phase with current source CS_1 providing current, switch S_1 open, and current flowing in the direction shown, through capacitor C_{DCB} and tissue T_1 (e.g. a volume of tissue). During this stimulation phase, charge accumulates in tissue T_1 . In Fig. 28C, implantable device 200 is in a passive charge recovery phase with current source CS_1 not providing current, and switch S_1 closed. During this charge recovery phase of Fig. 28C, stimulation elements 260a and 260b are shorted together, through capacitor C_{DCB} , and current flows in the direction shown, through switch S_1 , removing the charge in tissue T_1 developed during the stimulation phase of Fig. 28B.

[530] In Fig. 28D, a plot of current versus time is shown for the stimulation and passive charge recovery arrangement of Figs. 28B-C. A series of stimulation pulses are delivered, each with a time period TP_1 . In the time between stimulation pulses, time period TP_2 , charge recovery occurs for a time period TP_3 that is based on a RC discharge curve, where an associated resistance R_{TOT} and capacitance C_{TOT} represents the total resistance and capacitance, respectively, in the discharge path. Time period TP_3 is typically on the order of a few milliseconds.

[531] The passive charge recovery described in reference to Figs. 28C-D provides energy efficiency since energy (current) is only applied by implantable device 200 (e.g. by energy storage assembly 270, typically a battery or capacitor) during the stimulation phase (e.g. versus active charge recovery in which energy is provided in both stimulation phases and charge recovery phases). In the embodiment shown in Fig. 28D, the stimulation rate is sufficiently low (e.g. less than 1kHz) that the charge recovery period TP_3 is less than the time between stimulation pulses, time period TP_2 . However in some embodiments, the stimulation rate is

sufficiently high such that the charge recovery period TP_3 is greater than the time between pulses, time period TP_2 , such as is shown in Fig. 28E.

[532] In these high stimulation rate embodiments (e.g. at least 1 kHz up to hundreds of KHz), the duration of the stimulation pulse TP_1 and time between pulses TP_2 is much shorter than the RC time constant represented by time period TP_3 , such as when each is on the order of one-tenth to one-five hundredth the duration of TP_3 . In these embodiments, implantable device 200 is configured to allow charge due build up on the DC blocking capacitor C_{DCB} . This built-up charge translates to a bias voltage across capacitor C_{DCB} , which causes current to flow during the charge recovery period. An equilibrium is reached when the bias voltage across capacitor C_{DCB} equals the total resistance in the stimulation (R_{TOT}) path times the stimulation current when time period TP_1 and TP_2 are equal.

[533] Figs. 28F and 28G show waveforms of current through stimulation elements 260a and 260b (e.g. the current through tissue T_1) and voltage developed across capacitor C_{DCB} at low and high stimulation rates, respectively. As shown in Fig. 28G, a bias voltage is developed across capacitor C_{DCB} , which is approximately equal to the stimulation current during the stimulation phase times R_{TOT} (the total series resistance in the stimulation path). An increased compliance voltage is required by current source CS_1 to overcome the bias voltage of capacitor C_{DCB} . In some embodiments, there is a fixed minimum compliance voltage (minimum setting for the power supply 270 that powers the current source CS_1) and the stimulation current amplitude times R_{TOT} is less than or equal to 50% of the minimum compliance voltage. In these embodiments, energy can be recovered that would otherwise be wasted due to the minimum compliance voltage being greater than that required for active recovery. The long RC time constant requires a minimum amount of time (e.g. at least 2 milliseconds) for equilibrium to be reached. The asymmetry in the waveform can be mitigated by implantable device 200 ramping up and ramping down the stimulation current amplitude at the start and end of a time period in which stimulation energy is delivered.

[534] The equilibrium bias voltage on capacitor C_{DCB} is proportional to the ratio of the stimulation period TP_1 and the recovery time TP_2 , such that increasing the recovery time TP_2 relative to the stimulation time TP_1 will proportionally reduce the bias voltage on capacitor C_{DCB} , which will reduce the required compliance voltage. In this arrangement, control is provided in shaping the charge recovery phase, as both the recovery time and the stimulation path resistance can be manipulated to change the characteristics of the recovery pulse. For example, implantable device 200 can be configured to manipulate the timing in which switch S_1 is opened and/or closed, to control timing and/or duration of charge recovery. Alternatively or

additionally, implantable device 200 can be configured to manipulate the impedance of the discharge path, such as when implantable device 200 includes one or more resistive components that can be included and/or excluded from the stimulation path.

[535] While the embodiment of Figs. 28A-G is shown with two electrodes as stimulation elements 260, four, six, eight, or more stimulation elements 260 (e.g. electrodes) can be similarly configured to perform the passive charge recovery.

[536] While the preferred embodiments of the devices and methods have been described in reference to the environment in which they were developed, they are merely illustrative of the principles of the present inventive concepts. Modification or combinations of the above-described assemblies, other embodiments, configurations, and methods for carrying out the invention, and variations of aspects of the invention that are obvious to those of skill in the art are intended to be within the scope of the claims. In addition, where this application has listed the steps of a method or procedure in a specific order, it may be possible, or even expedient in certain circumstances, to change the order in which some steps are performed, and it is intended that the particular steps of the method or procedure claim set forth herebelow not be construed as being order-specific unless such order specificity is expressly stated in the claim.

CLAIMS

WHAT IS CLAIMED IS:

1. A medical apparatus for a patient, comprising:

an external system configured to transmit one or more transmission signals, each transmission signal comprising at least power or data; and

an implantable system configured to receive the one or more transmission signals from the external system;

wherein the external system comprises a first external device comprising:

at least one external antenna configured to transmit a first transmission signal to the implantable system, the first transmission signal comprising at least power or data;

an external transmitter configured to drive the at least one external antenna;

an external power supply configured to provide power to at least the external transmitter; and

an external controller configured to control the external transmitter; and

wherein the implantable system comprises a first implantable device comprising:

at least one implantable antenna configured to receive the first transmission signal from the first external device;

an implantable receiver configured to receive the first transmission signal from the at least one implantable antenna;

at least one implantable stimulation element configured to deliver stimulation

energy to the patient;

an implantable controller configured to control the stimulation energy delivered to the at least one implantable stimulation element;

an implantable energy storage assembly configured to provide power to an element selected from the group consisting of: the at least one implantable stimulation element; the implantable controller; the implantable receiver; and combinations thereof; and

an implantable housing surrounding at least the implantable controller and the implantable receiver.

2. The apparatus as claimed in at least one of the preceding claims,

wherein the at least one implantable antenna is positioned outside of the implantable housing, and

wherein the first implantable device further comprises:

one or more electrical components positioned within the implantable housing, and

a tether that electrically connects the at least one implantable antenna to the one or more electrical components.

3. The apparatus as claimed in at least one of the preceding claims, wherein the first implantable device further comprises:

one or more functional elements positioned outside of the implantable housing;

one or more electrical components positioned within the implantable housing;
and

a tether that electrically connects the one or more functional elements to the
one or more electrical components.

4. The apparatus as claimed in at least one of the preceding claims, wherein the first external device is configured to be positioned on the skin of the patient proximate the first implantable device, and wherein the apparatus is configured to provide feedback regarding the quality of the positioning of the first external device.
5. The apparatus as claimed in at least one of the preceding claims, wherein the apparatus is configured to determine the quality of the first transmission signal by measuring the power consumption of the first external device.
6. The apparatus according to claim 5, wherein the position of the first external device is configured to be optimized based on the determined quality of the first transmission signal.
7. The apparatus according to claim 5, wherein the apparatus is further configured to determine the quality of the first transmission using a reference RSSI.
8. The apparatus according to claim 7, wherein the apparatus compares the reference RSSI to a measured signal level of the first external device to determine the quality of the first transmission signal.
9. The apparatus according to claim 7, wherein the reference RSSI comprises a reference selected from the group consisting of: a reference determined during a manufacturing process of the apparatus; a reference based on a characterization of a population of previously manufactured external devices and implantable devices; a reference determined during patient use of the apparatus; a reference determined during a calibration process; and combinations thereof.

10. The apparatus according to claim 5, wherein the apparatus further comprises one or more user output components, and wherein the apparatus is further configured to provide feedback information related to the determined quality of the first transmission signal via the one or more user output components.
11. The apparatus according to claim 10, wherein the feedback information comprises a good/bad assessment.
12. The apparatus according to claim 10, wherein the feedback information comprises a multi-level assessment comprising three or more levels.
13. The apparatus according to claim 10, wherein the feedback information is used to optimize the position of the first external device on the patient's skin.
14. The apparatus according to claim 13, wherein the feedback information comprises the first external device skin position information that is indicated by a changing graph, a changing quantity, and/or a changing tone.
15. The apparatus as claimed in at least one of the preceding claims,

wherein the first implantable device further comprises:

one or more implantable leads comprising the at least one stimulation element,
and

wherein the apparatus further comprises a trialing interface comprising:

an electronic assembly;
a first connector; and
an interface connector comprising a second connector removably attached to
the first connector;

wherein the interface connector is configured for operably and removably attaching to
the one or more implantable leads.

16. The apparatus according to claim 15, wherein the electronic assembly comprises a first detection circuitry and the interface connector comprises a second detection circuitry, and wherein the trialing interface is configured to detect proper connection of the first connector and the second connector via the first detection circuitry and the second detection circuitry.
17. The apparatus according to claim 16, wherein the trialing interface is configured to repeatedly detect the proper connection.
18. The apparatus according to claim 16, wherein the second connector comprises multiple contacts, wherein the second detection circuitry comprises a connection of known resistance between two or more of the multiple contacts, and wherein the electronic assembly is configured to detect the proper connection based on the known resistance.
19. The apparatus according to claim 16, wherein the trialing interface is configured to detect the proper connection without using a direct current signal.
20. The apparatus according to claim 16, wherein the trialing interface is configured to detect the proper connection using an alternating current signal.
21. The apparatus according to claim 20, wherein the alternating current signal comprises a digital pulse, and wherein the electronic assembly is configured to detect a high state during the pulse and a low state after the pulse.
22. The apparatus according to claim 21, wherein the trialing interface is configured to repeatedly detect the proper connection by repeatedly delivering the digital pulse.
23. The apparatus according to claim 16, wherein the trialing interface is

configured to detect the first connector and the second connector transitioning from a disconnected state to a connected state, and wherein the apparatus is configured to avoid full amplitude signal delivery to the patient at the time of the connection.

24. The apparatus according to claim 23, wherein the apparatus is configured to deliver stimulation energy at a first level prior to the time of the connection, and to initiate a new stimulation delivery in which the amplitude level is slowly ramped up after the time of the connection.
25. The apparatus according to claim 24, wherein the amplitude is ramped up over a period of 1 second to 10 seconds.
26. The apparatus as claimed in at least one of the preceding claims, further comprising a charging device, wherein the first external device comprises multiple electrical contacts configured to electrically connect to the charging device to receive energy to recharge the external power supply.
27. The apparatus according to claim 26, wherein the first external device further comprises switching circuitry configured as a passivation module that reduces corrosion of the multiple electrical contacts.
28. The apparatus according to claim 27, wherein the switching circuitry is configured to remove voltage from the multiple electrical contacts when the first external device is not operably connected to the charging device.
29. The apparatus according to claim 28, wherein the switching circuitry comprises a first transistor which detects that the first external device is operably connected to the charging device.
30. The apparatus according to claim 26, wherein the first external device is configured to detect an operable connection to the charging device.

31. The apparatus according to claim 30, wherein the first external device is configured to at least limit transmissions of power and/or data to the first implantable device when the first external device is operably connected to the charging device.
32. The apparatus according to claim 30, wherein the first external device is configured to enter a sleep state when the first external device is operably connected to the charging device.
33. The apparatus as claimed in at least one of the preceding claims, wherein the at least one stimulation element comprises multiple stimulation elements, wherein the first implantable device further comprises:
one or more implantable leads, each lead comprising two or more stimulation elements of the multiple stimulation elements, and
wherein the first implantable device does not comprise a monopolar return path for the delivery of the stimulation energy by the multiple stimulation elements.
34. The apparatus according to claim 33, wherein the first implantable device is configured to be in a pseudo-monopolar mode, and to measure impedance of the multiple stimulation elements when in the pseudo-monopolar mode.
35. The apparatus according to claim 34, wherein the pseudo-monopolar mode comprises a first stimulation element of the multiple stimulation elements being configured as a cathode, and the remaining of the multiple stimulation elements each being configured as an anode.
36. The apparatus according to claim 35, wherein the first implantable device comprises a current source, and wherein the impedance associated with the first stimulation element is determined by measuring a resulting voltage pulse that is generated at the first stimulation element when the current source delivers a current pulse to the first stimulation element.

37. The apparatus according to claim 35, wherein the pseudo-monopolar mode comprises a second stimulation element of the multiple stimulation elements being configured as a cathode, and the remaining of the multiple stimulation elements each being configured as an anode.
38. The apparatus according to claim 37, wherein the impedance of the second stimulation element is measured by measuring a resulting voltage pulse that is generated at the second stimulation element when the current source delivers a current pulse to the second stimulation element.
39. The apparatus as claimed in at least one of the preceding claims, wherein the at least one stimulation element comprises multiple stimulation elements, and wherein the first implantable device is configured to detect a short between a first stimulation element and a second stimulation element.
40. The apparatus according to claim 39, wherein the first implantable device further comprises a current source configured to deliver a current pulse to the first stimulation element while the first implantable device connects the remaining stimulation elements to ground, and wherein the implantable device detects the short between the first stimulation element and the second stimulation element if the resulting voltage is below a threshold.
41. The apparatus according to claim 39, wherein the first implantable device further comprises a current source configured to deliver a current pulse to the first stimulation element, and wherein the implantable device detects the short between the first stimulation element and the second stimulation element if the resulting voltage is above a threshold.
42. The apparatus as claimed in at least one of the preceding claims, wherein the at least one stimulation element comprises multiple stimulation elements, and wherein the first implantable device is configured to detect an open circuit at a stimulation element.

43. The apparatus as claimed in at least one of the preceding claims, wherein the apparatus is configured such that the one or more transmission signals are relatively unaffected by a rotational orientation of the first external device.
44. The apparatus as claimed in at least one of the preceding claims, wherein the at least one stimulation element is configured to deliver a sequence of monophasic pulses.
45. The apparatus according to claim 44, wherein the at least one stimulation element comprises multiple stimulation elements configured to deliver stimulation energy to multiple tissue locations sequentially.
46. The apparatus according to claim 45, wherein the monophasic pulses are sequenced within the stimulation interval per the pulse width and inter-pulse gaps for each tissue location.
47. The apparatus as claimed in at least one of the preceding claims, wherein the first implantable device is configured to increase compliance voltage and to perform passive charge recovery.

Nalu Medical, Inc.

Patent Attorneys for the Applicant/Nominated Person

SPRUSON & FERGUSON

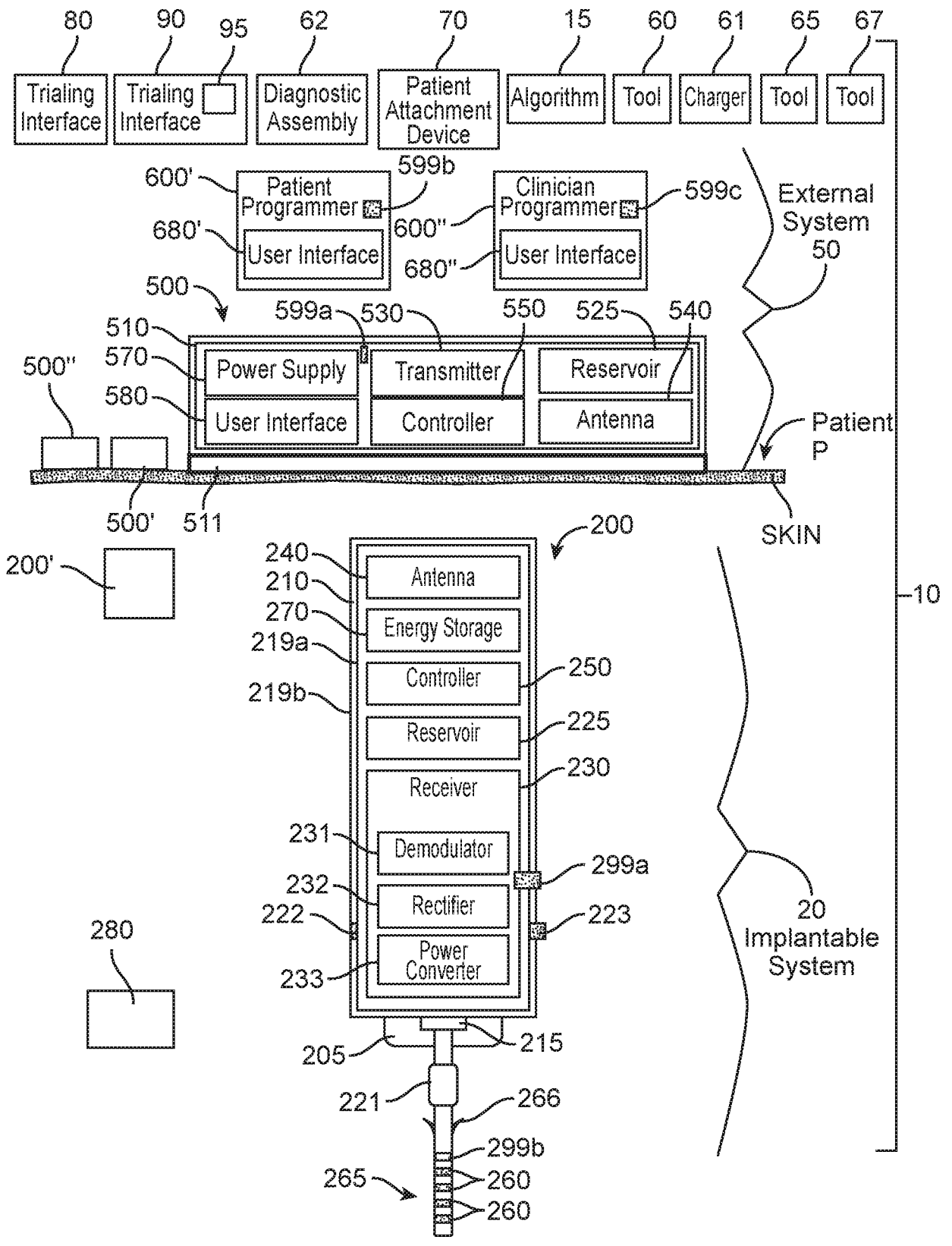

FIG. 1

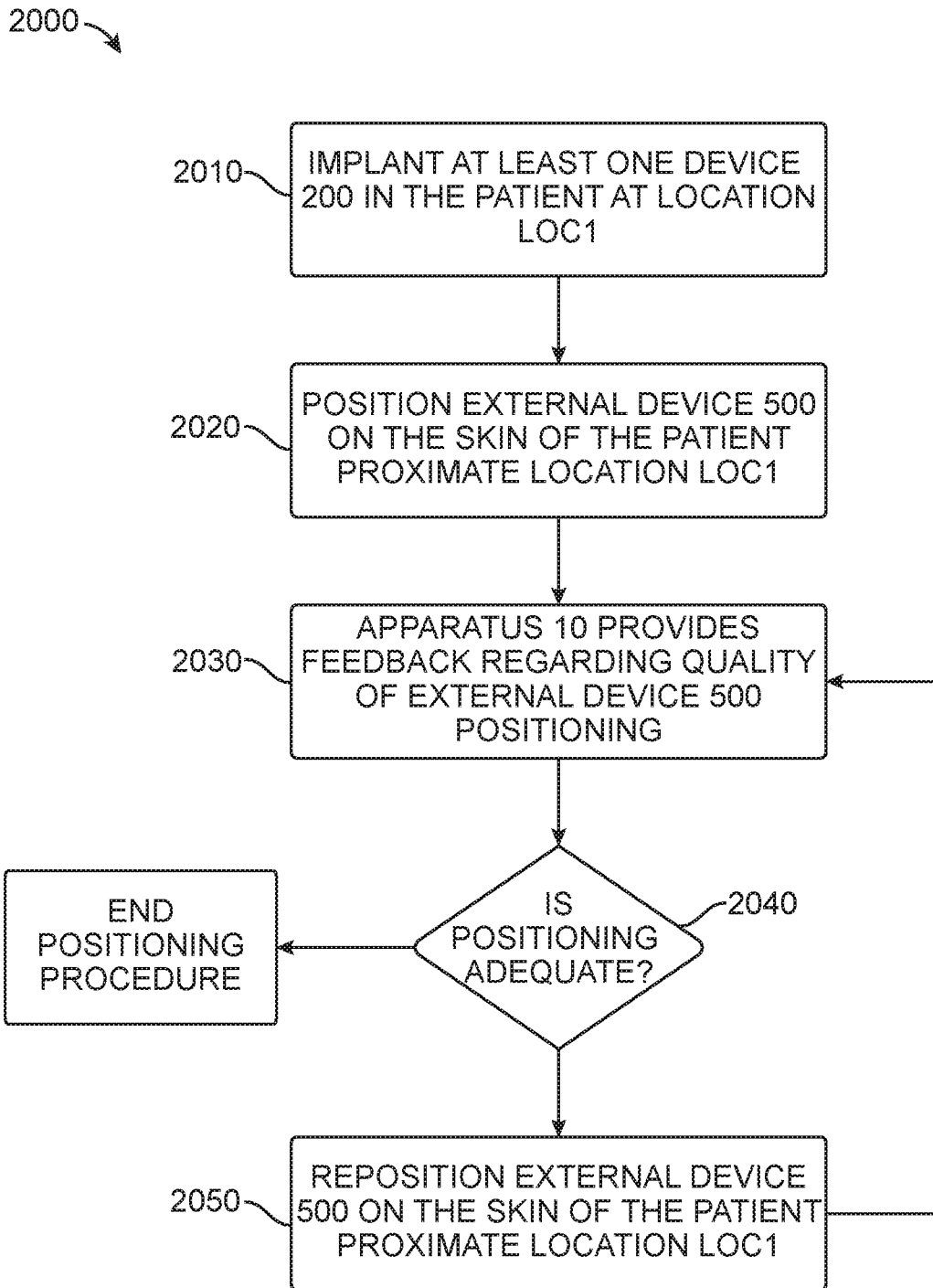

FIG. 2

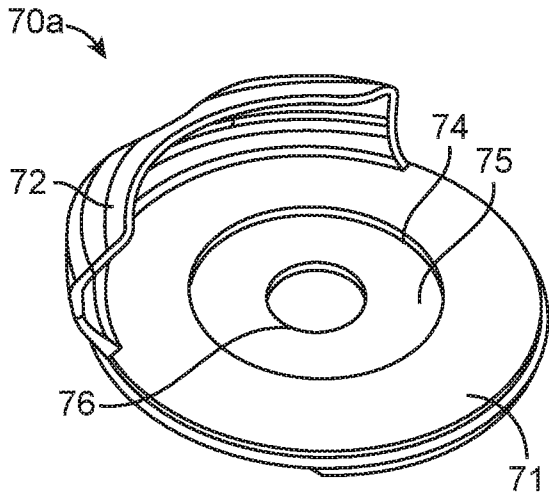

FIG. 3A

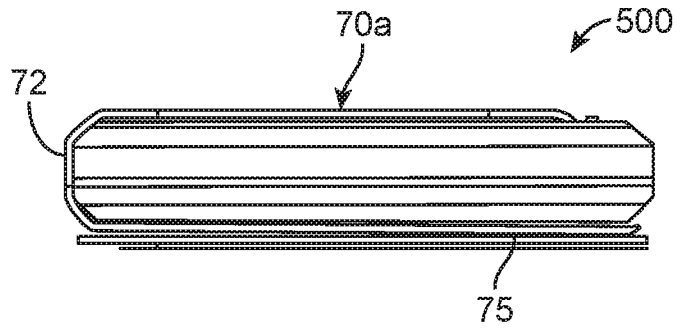

FIG. 3B

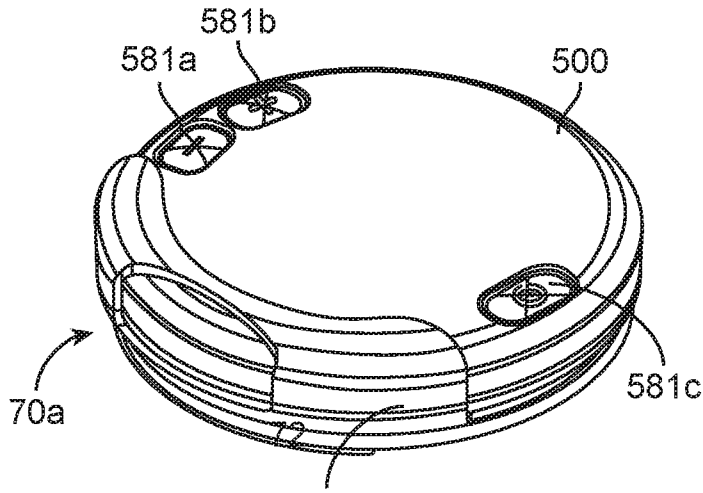

FIG. 3C

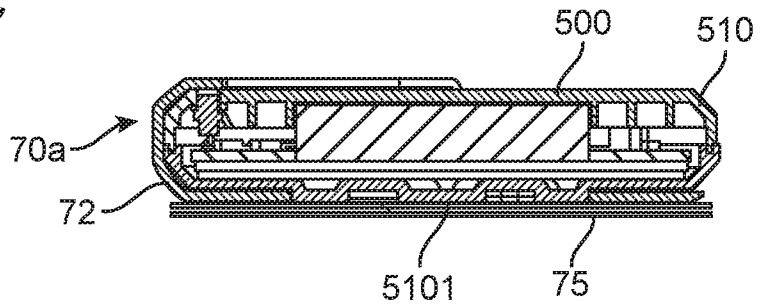

FIG. 3D

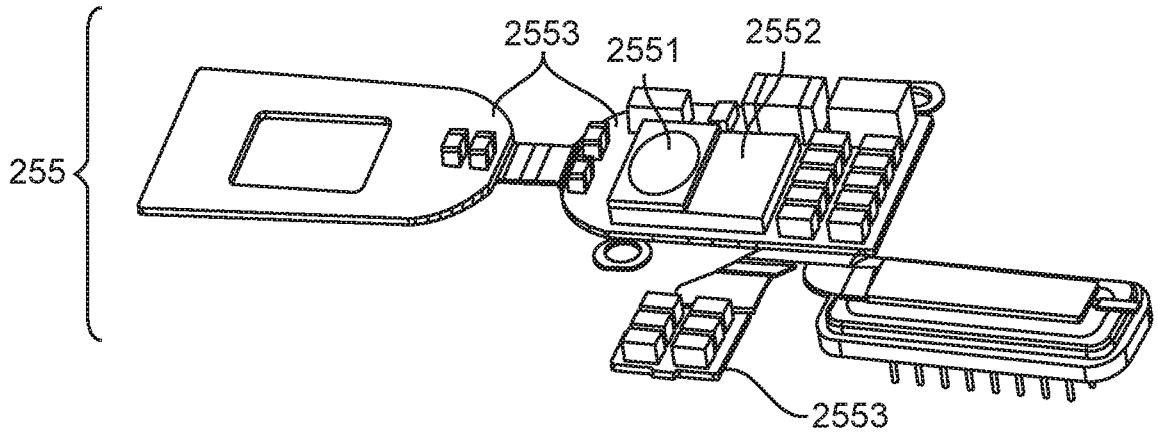

FIG. 4A

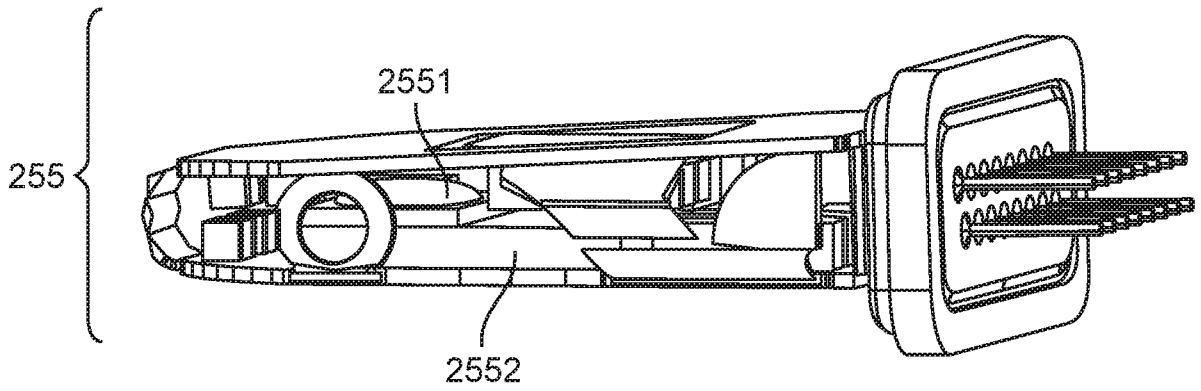

FIG. 4B

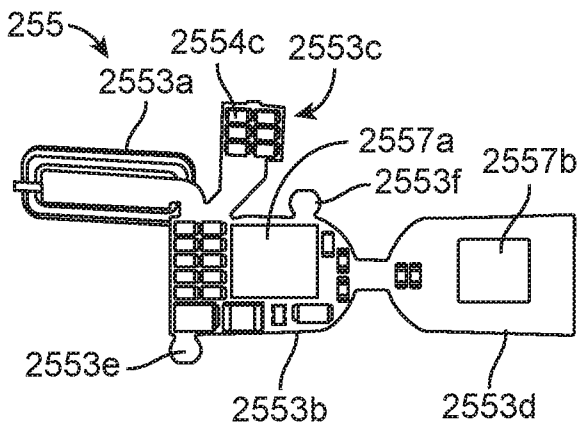

FIG. 5A

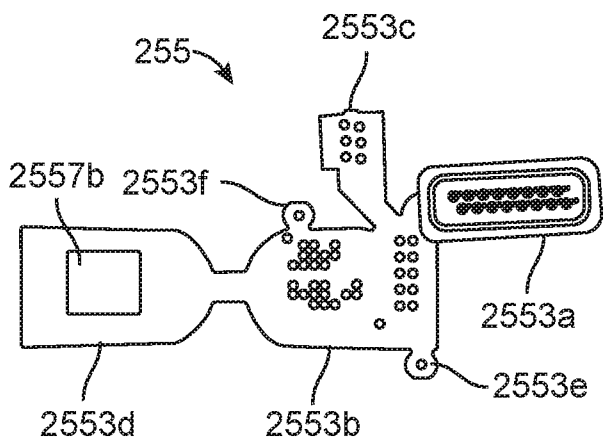

FIG. 5B

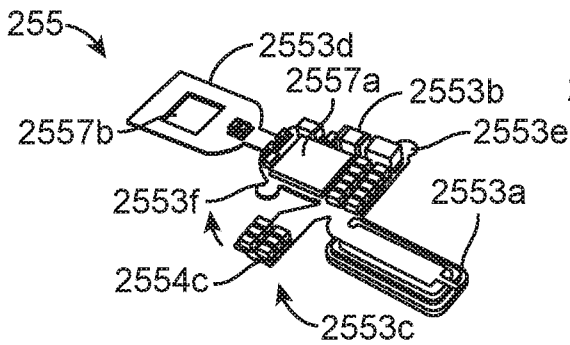

FIG. 5C

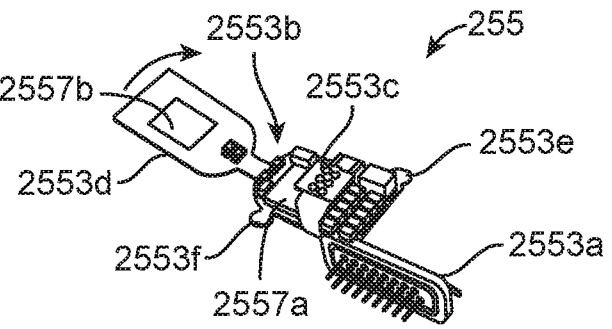

FIG. 5D

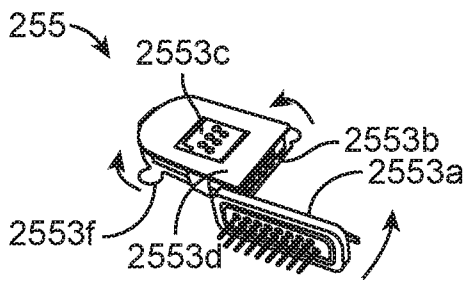

FIG. 5E

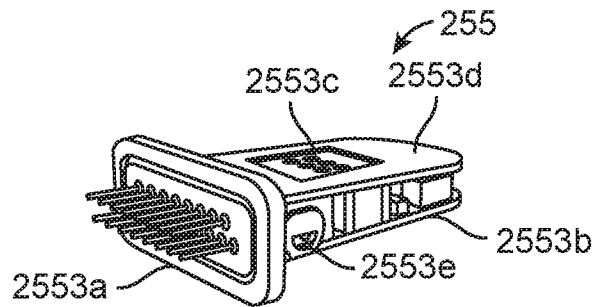

FIG. 5F

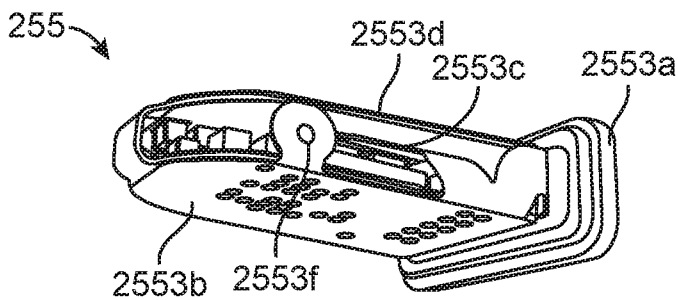

FIG. 5G

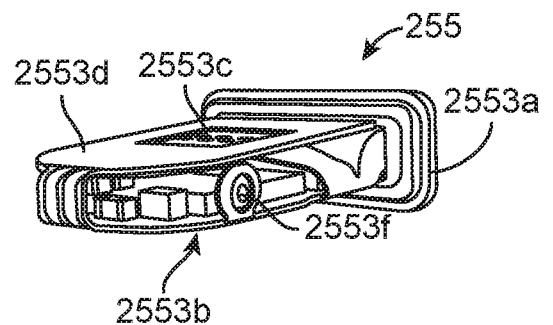

FIG. 5H

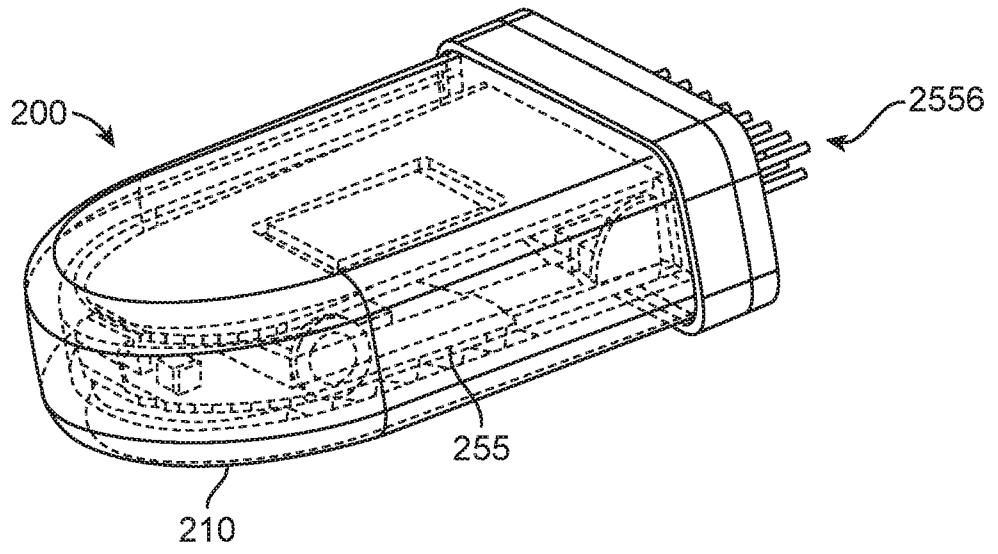

FIG. 6A

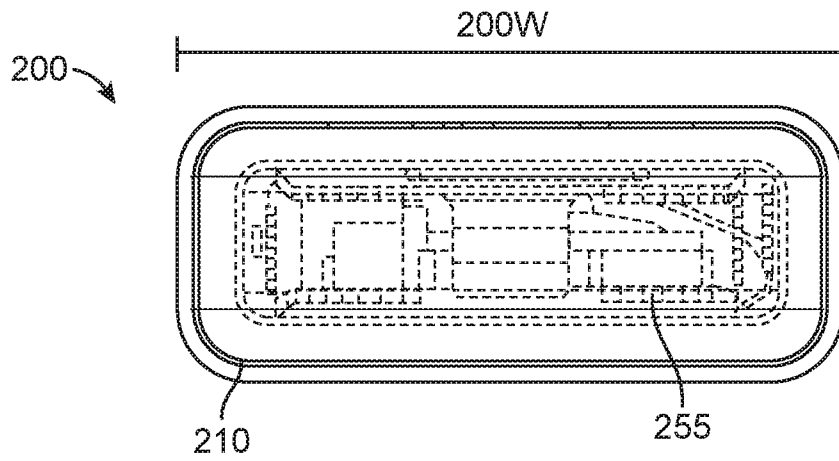

FIG. 6B

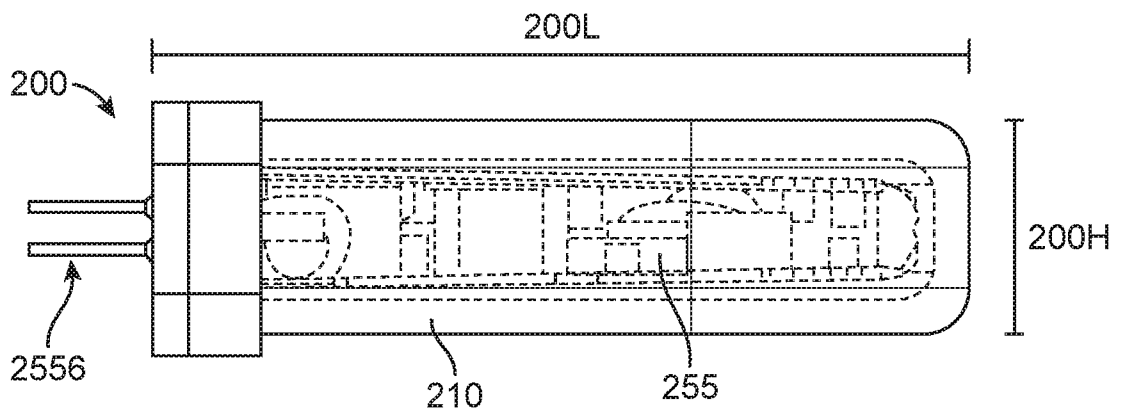

FIG. 6C

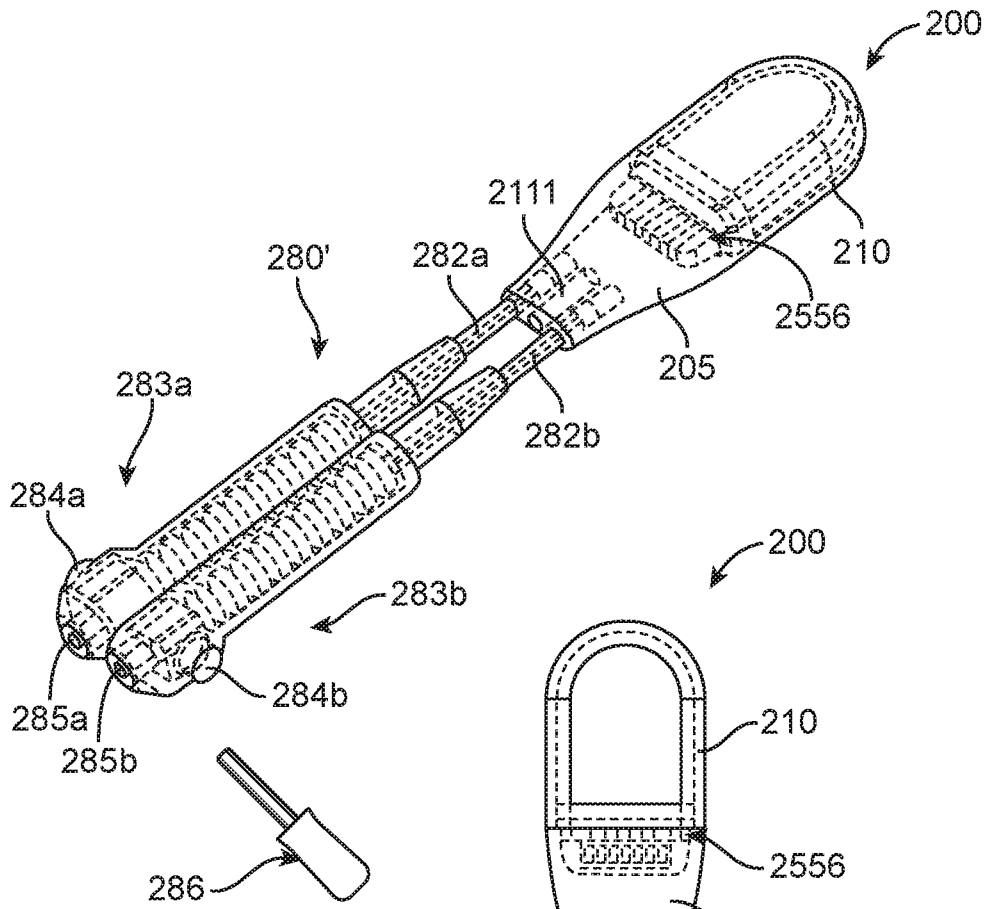

FIG. 7A

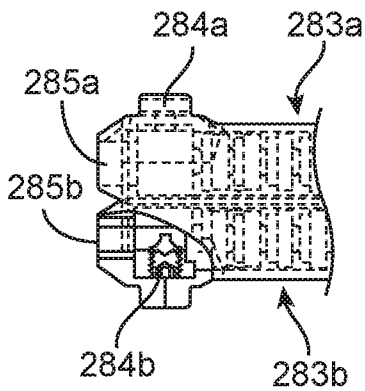

FIG. 7D

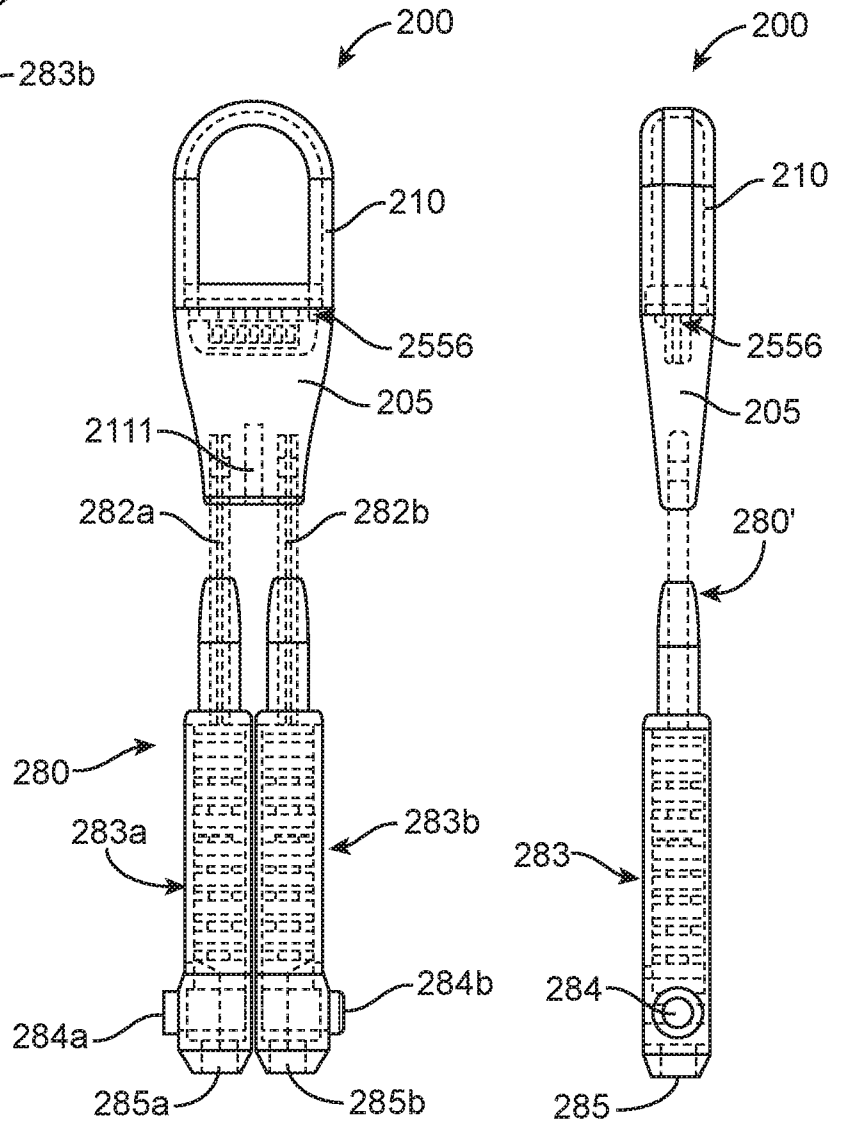

FIG. 7B

FIG. 7C

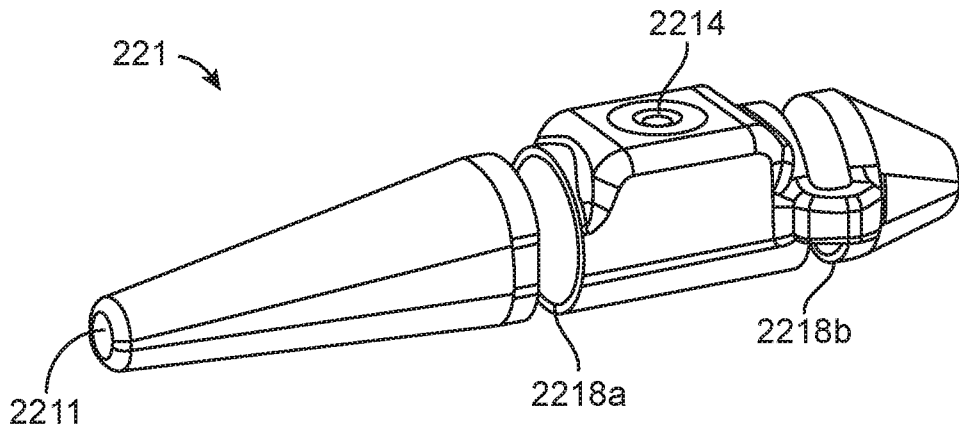

FIG. 8A

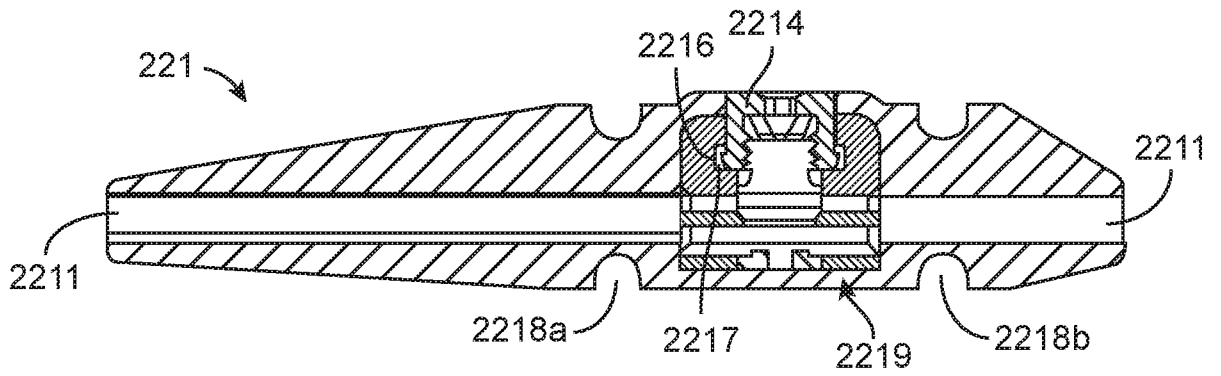

FIG. 8B

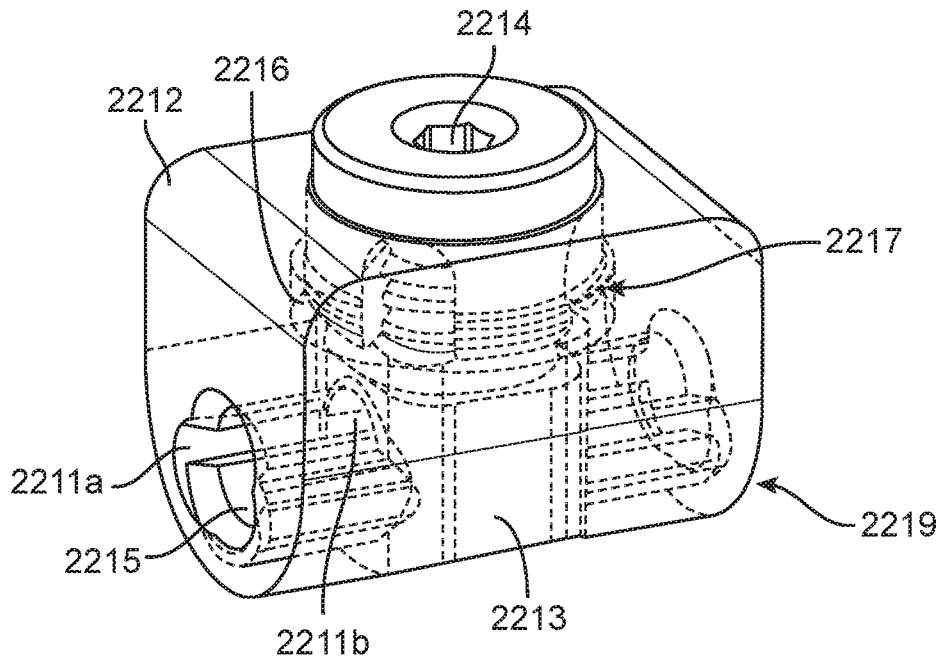

FIG. 8C

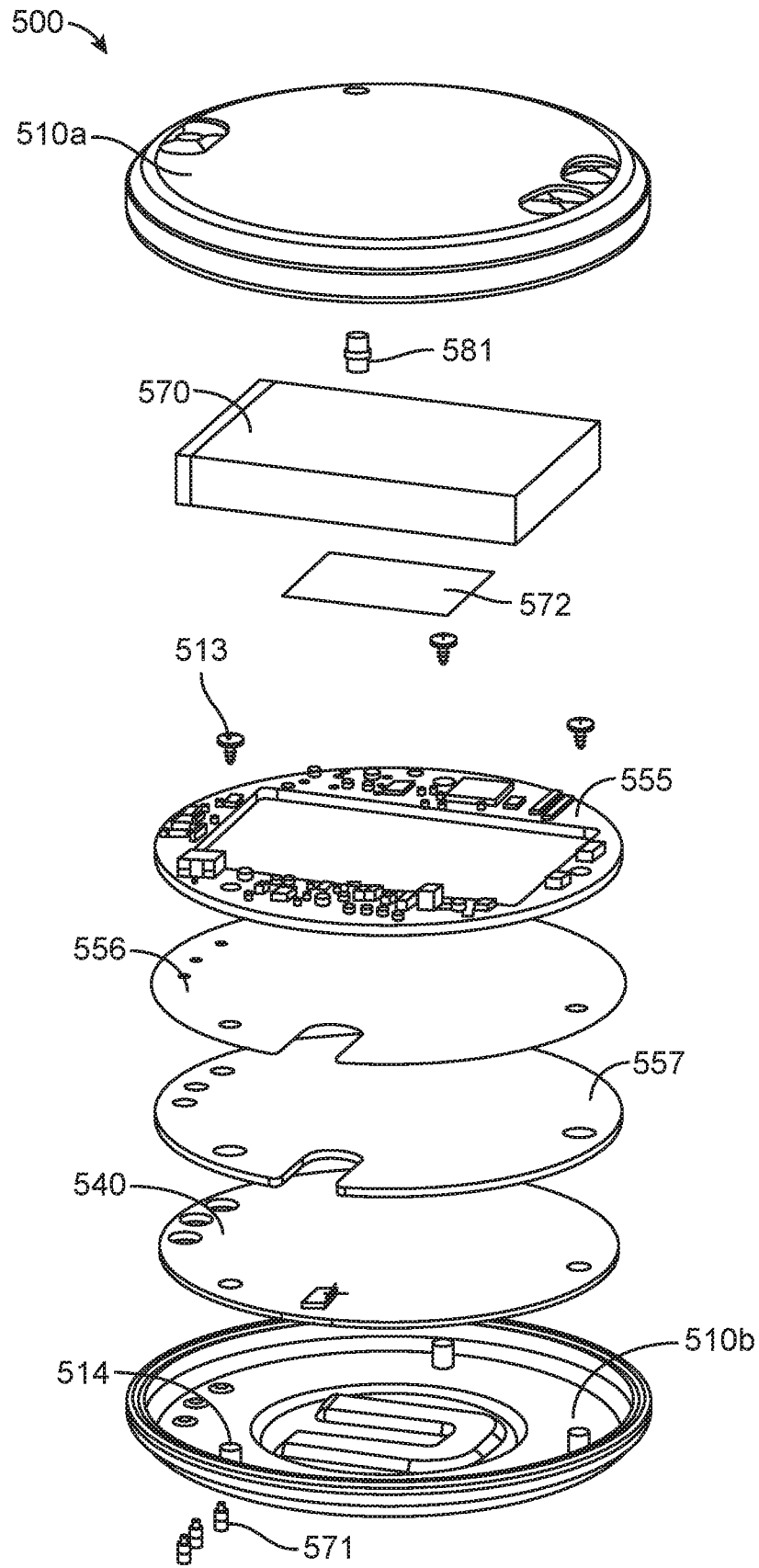

FIG. 10

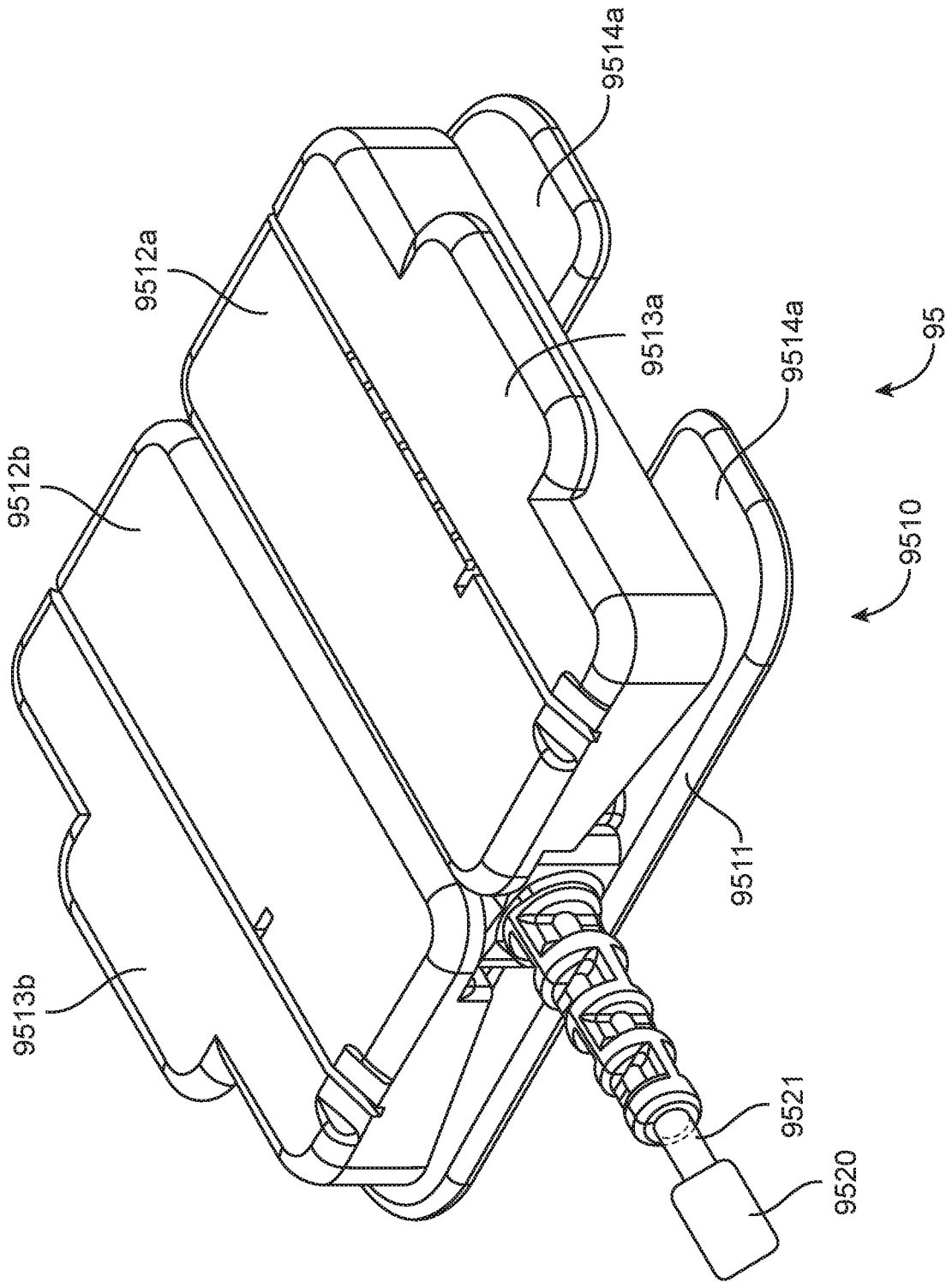

FIG. 11A

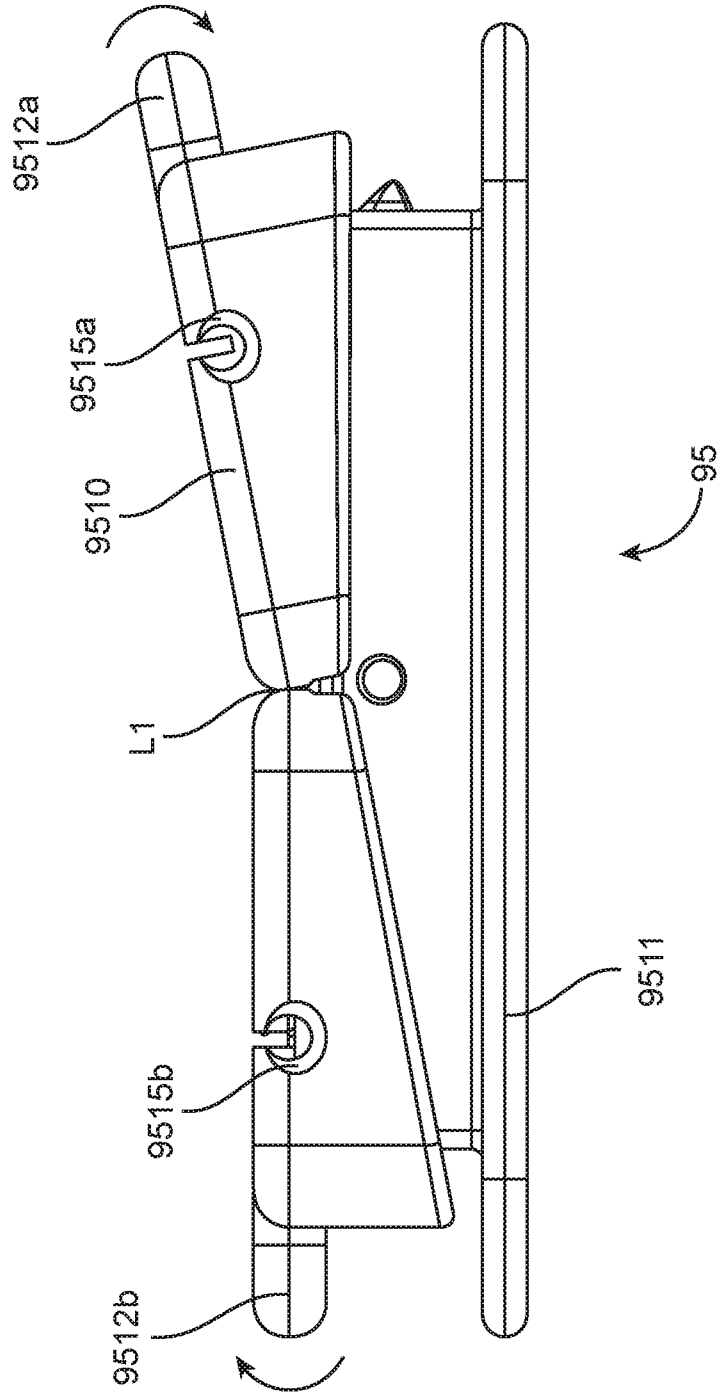

FIG. 11B

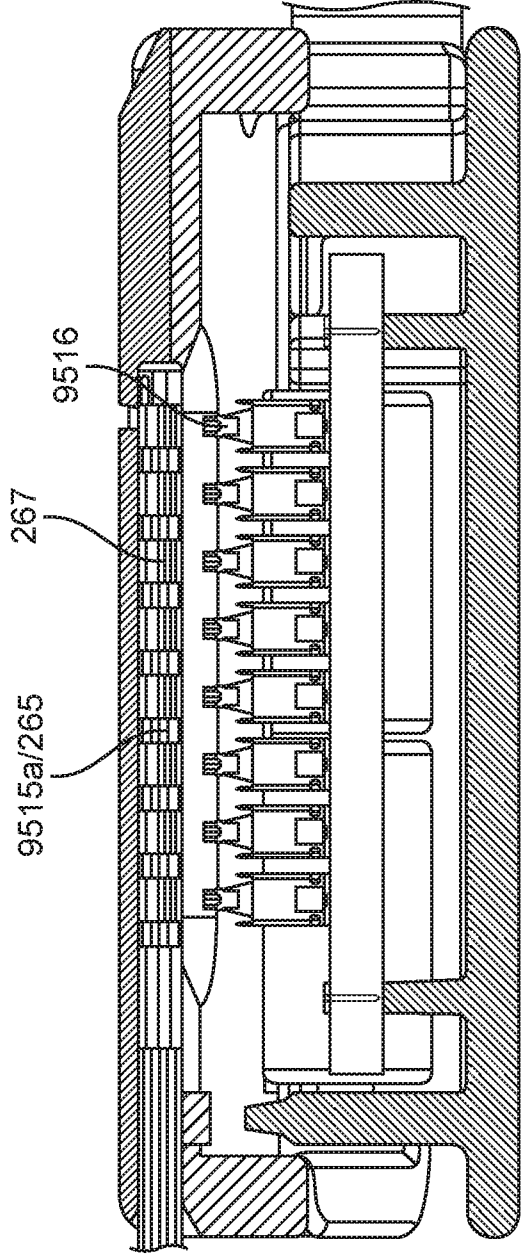

FIG. 11C

95

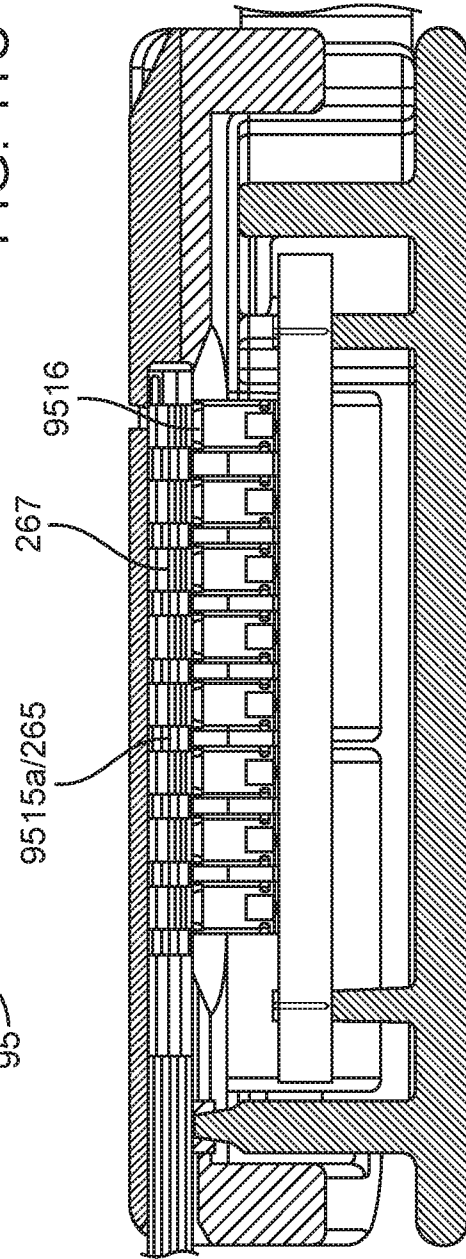

FIG. 11D

95

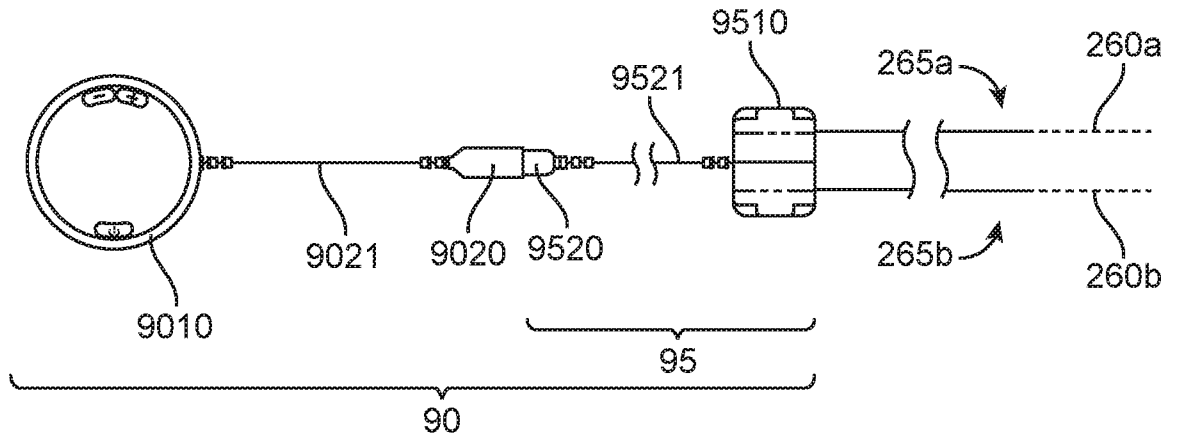

FIG. 12A

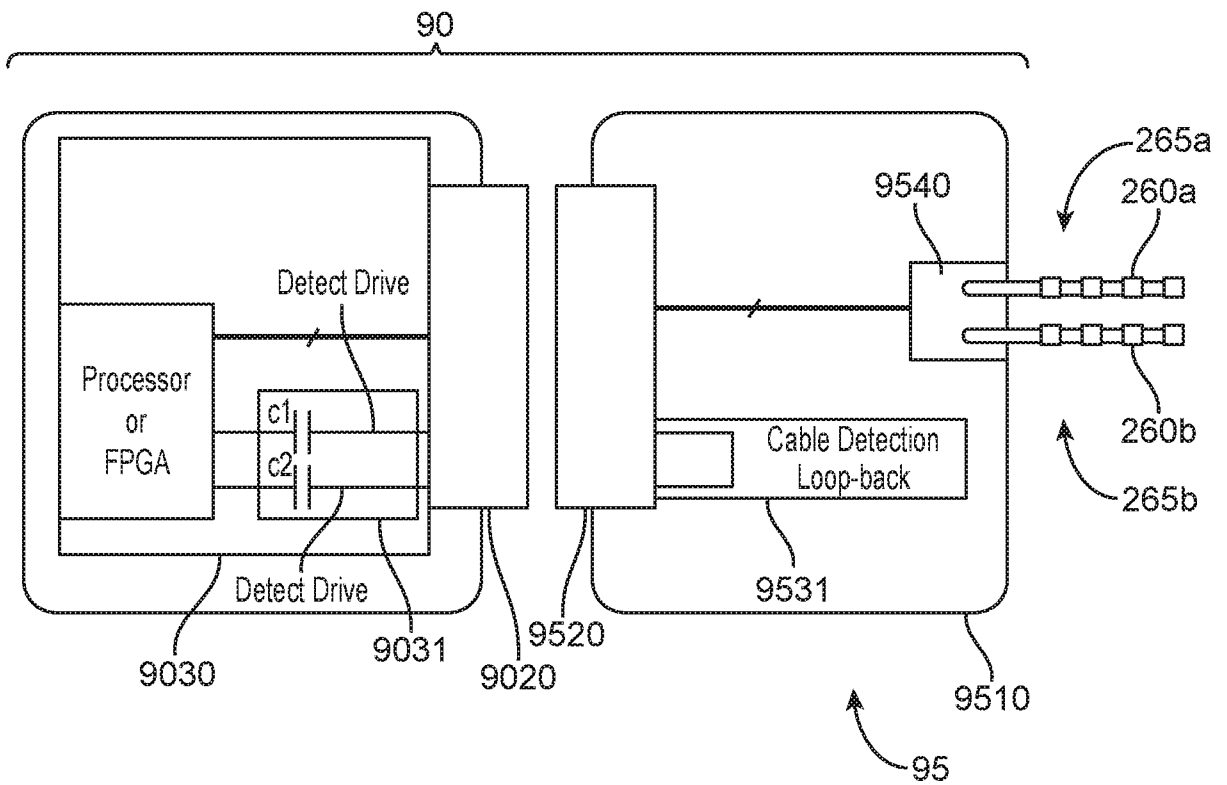

FIG. 12B

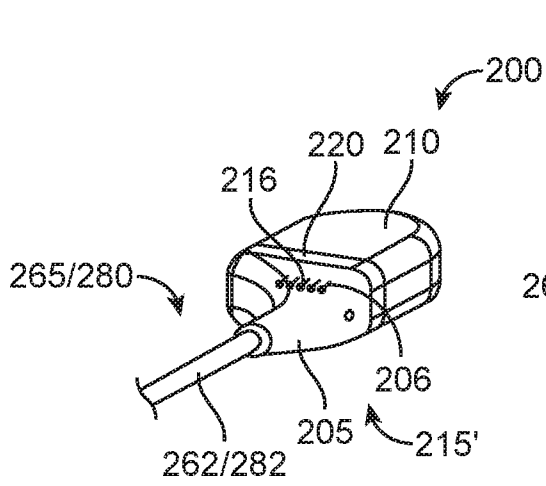

FIG. 13A

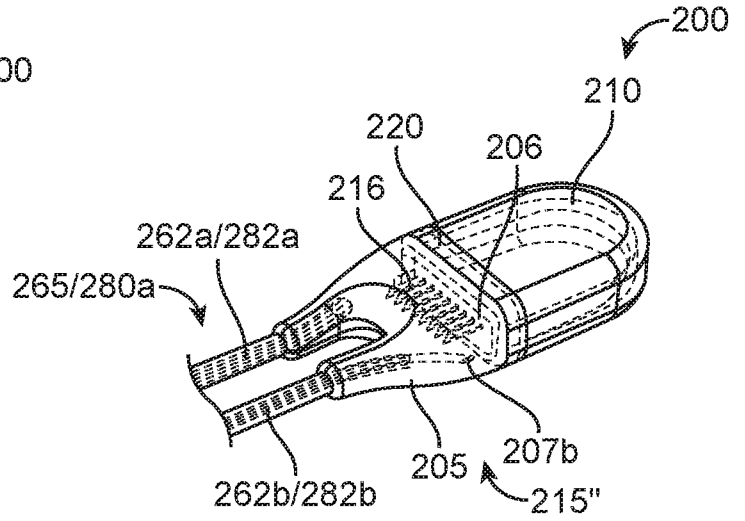

FIG. 13B

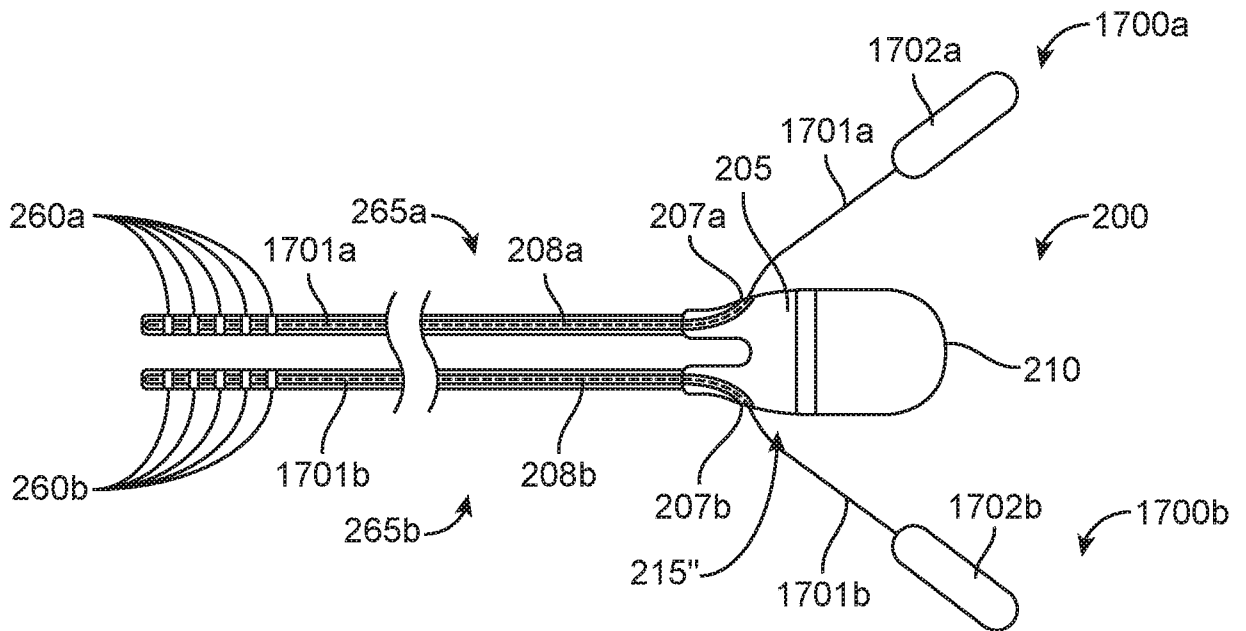

FIG. 13C

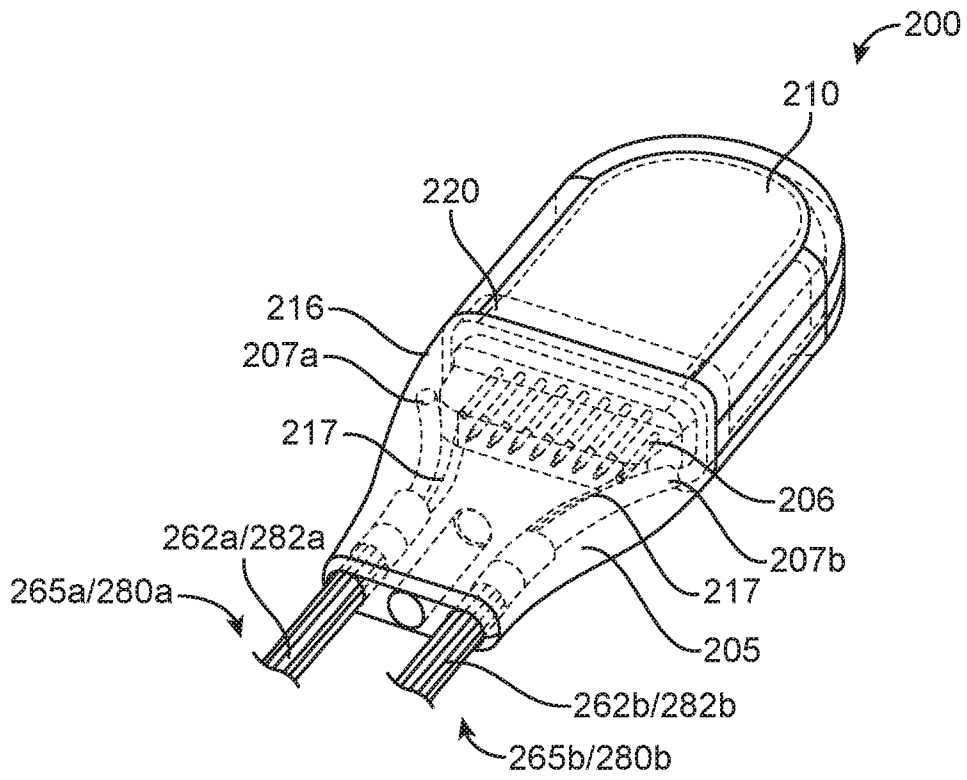

FIG. 14A

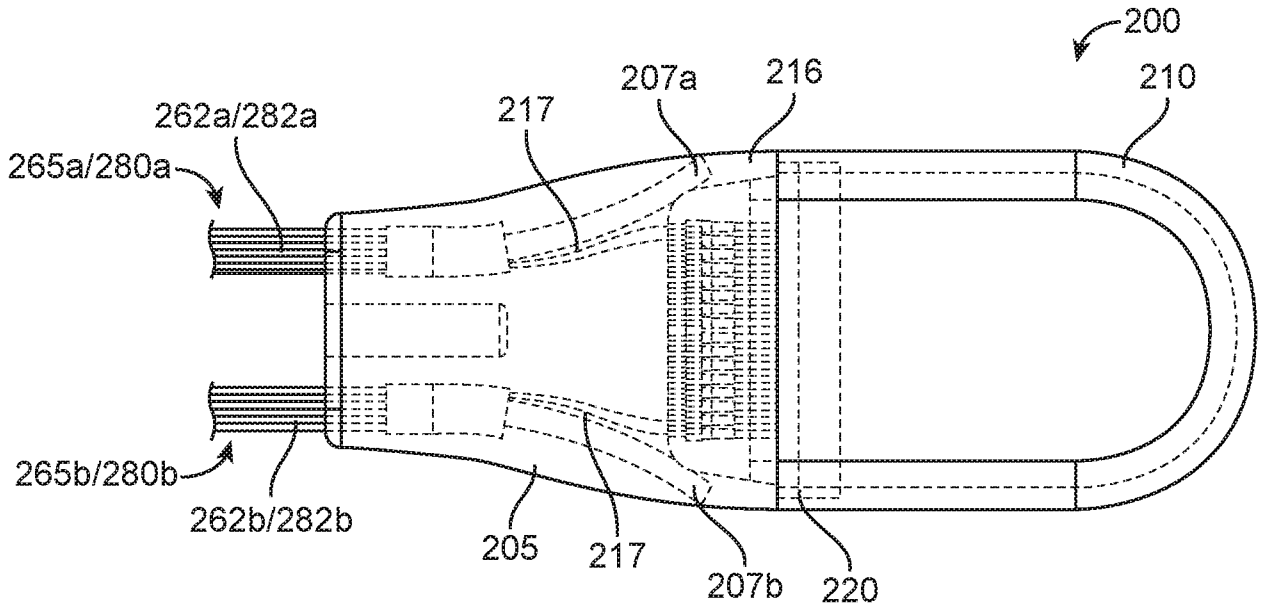
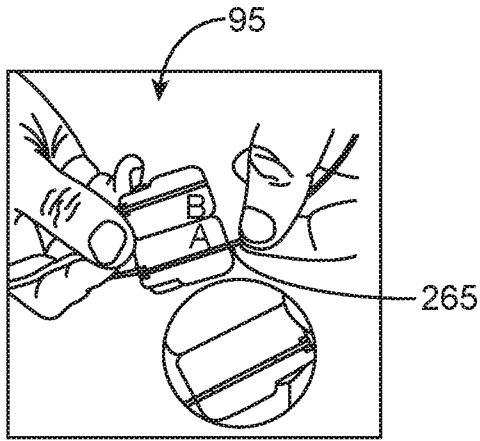
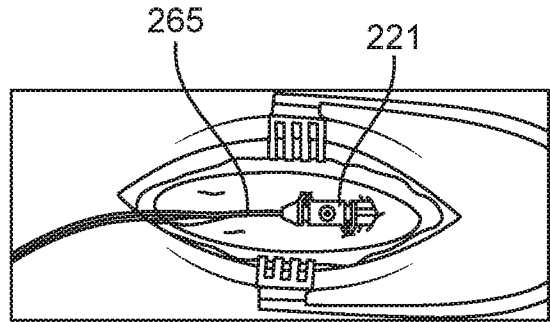

FIG. 14B



Connecting to the lead(s) 265

FIG. 15A



Lead 265 Ancohor 221 at incision site

FIG. 15B

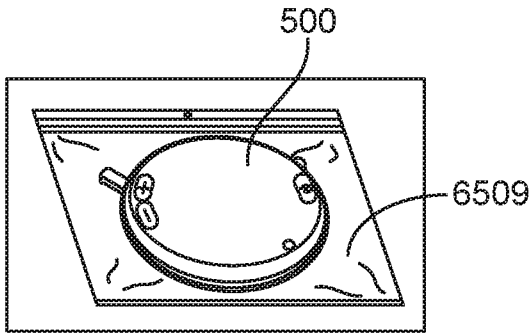

External Device 500 in sterile bag

FIG. 15C

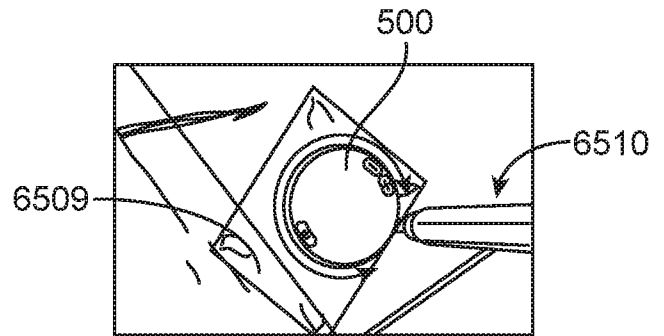

Trace outline of the External Device 500

FIG. 15D

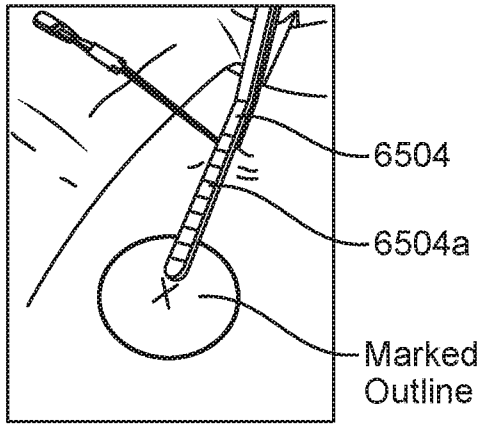

Tunneler 6504

FIG. 15E

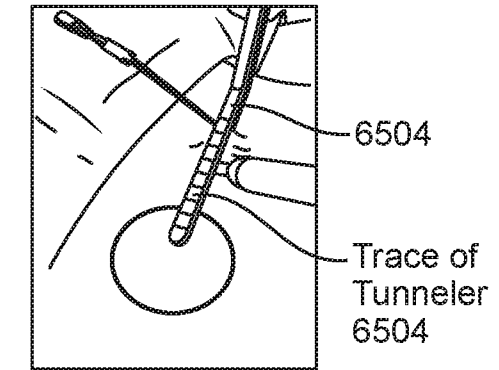

Trace Tunneler 6504

FIG. 15F

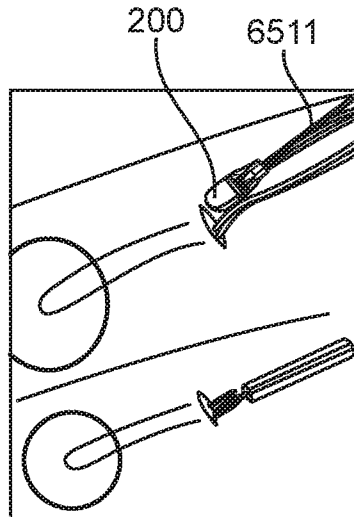

Using the Implantable Pulse Generator Insertion tool to advance the Implantable Pulse Generator

FIG. 15G

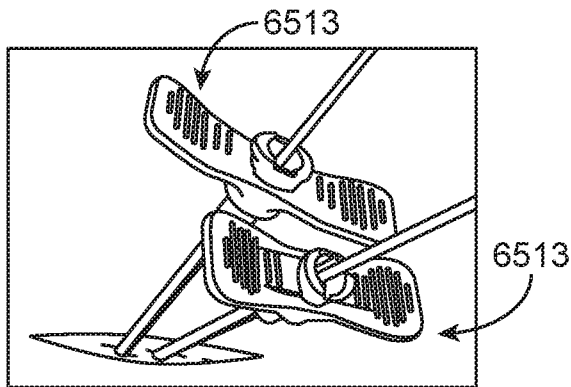
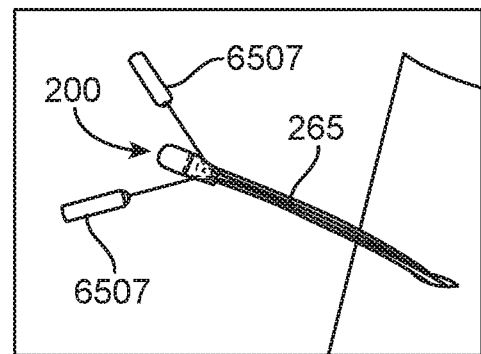

Image of leads passing through the Tearaway Introducer

FIG. 15H



Stylets loaded into integrated implanted Pulse Generator

FIG. 15I

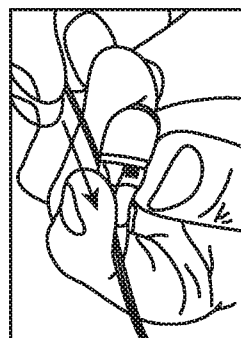

Lead Alignment

FIG. 15J

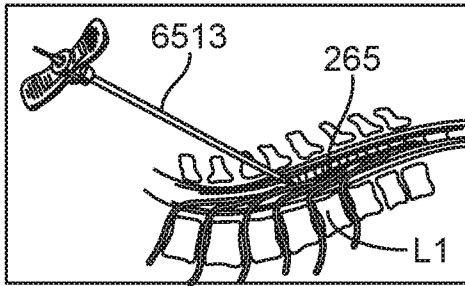

Cross-sectional image of spine with Tearaway Introducer and lead deployed

FIG. 15K

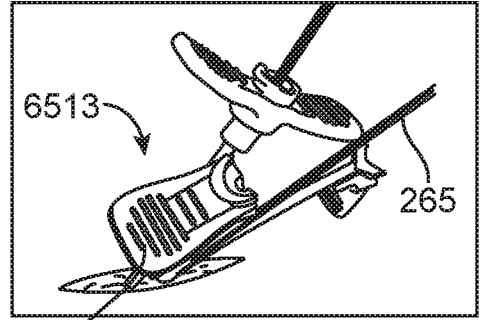

Splitting tearaway sheaths

HUB TAB

FIG. 15L

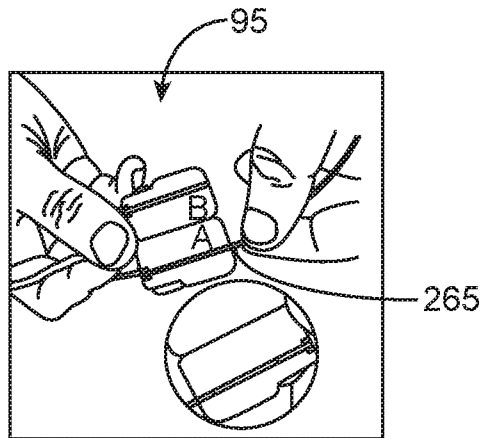

Connecting to the lead(s) 265

FIG. 15M

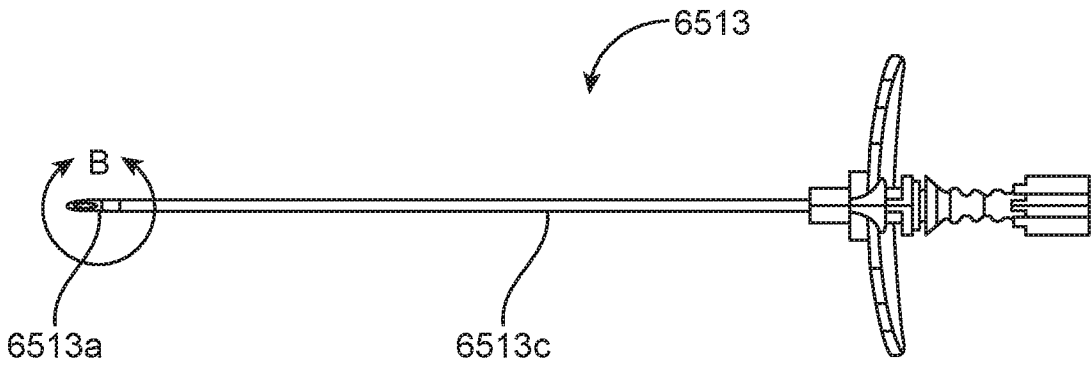

FIG. 16A

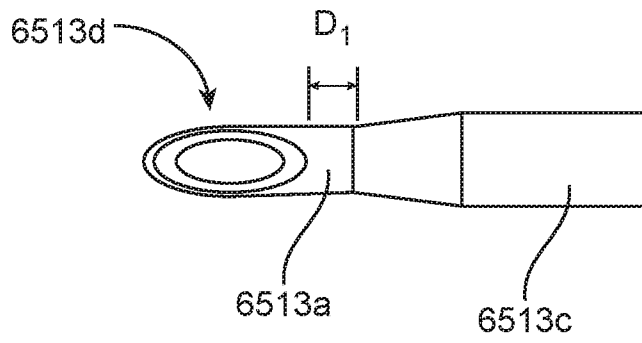

FIG. 16B

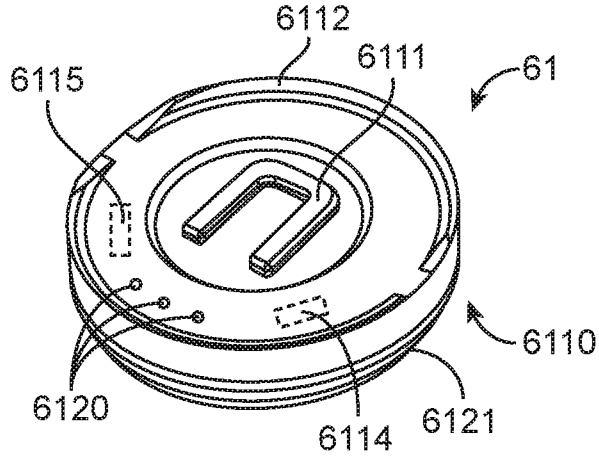

FIG. 17A

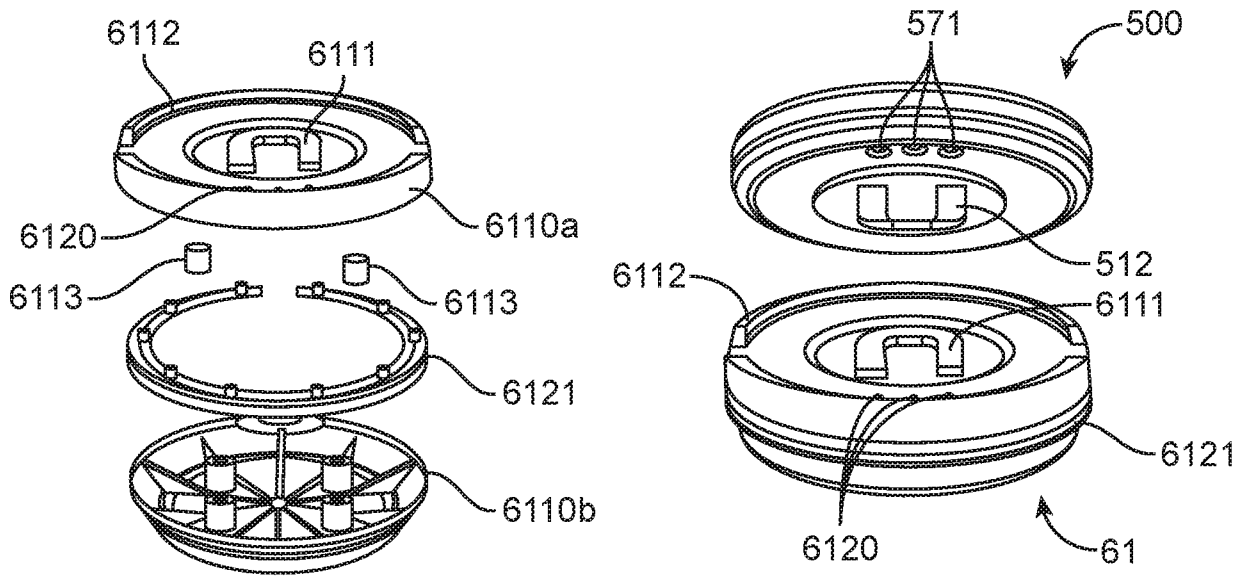

FIG. 17B

FIG. 17C

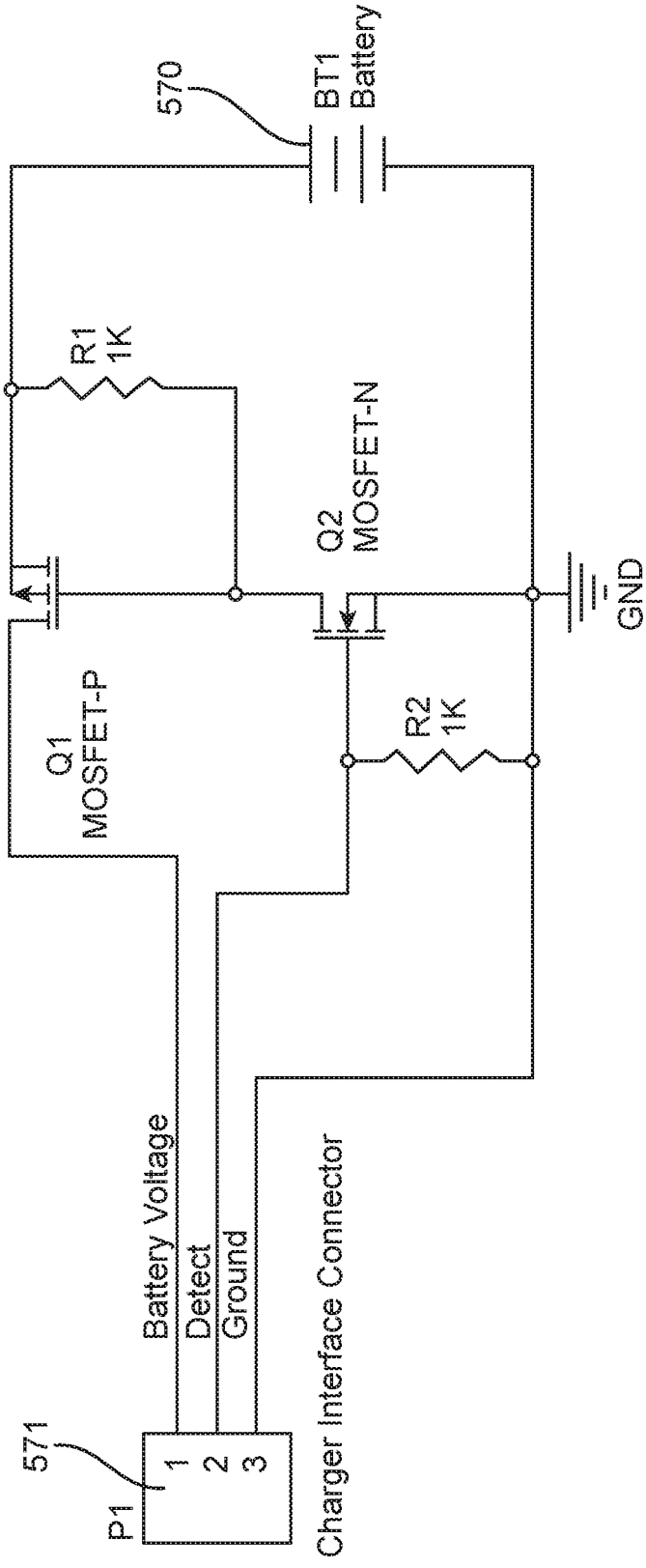

FIG. 17D

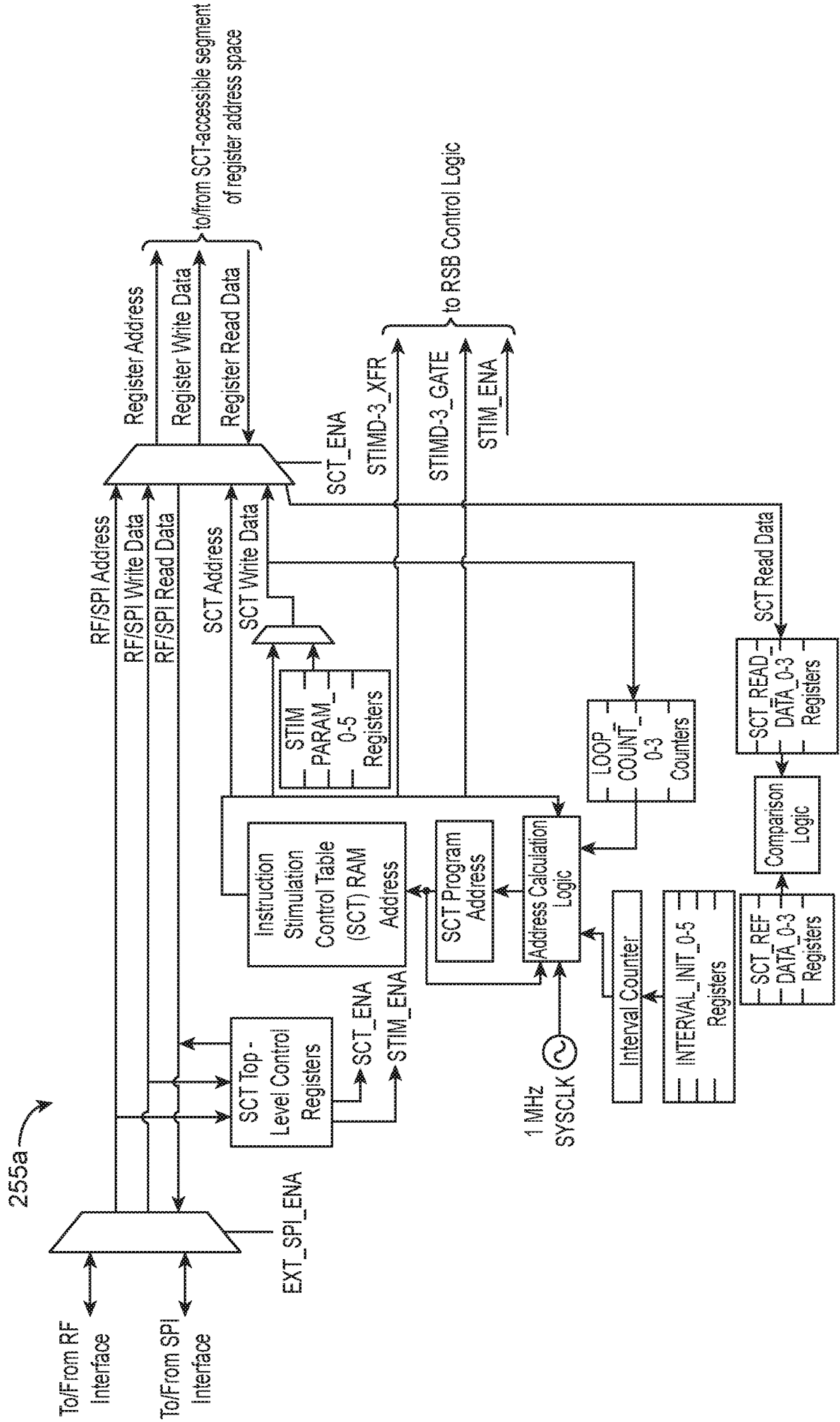
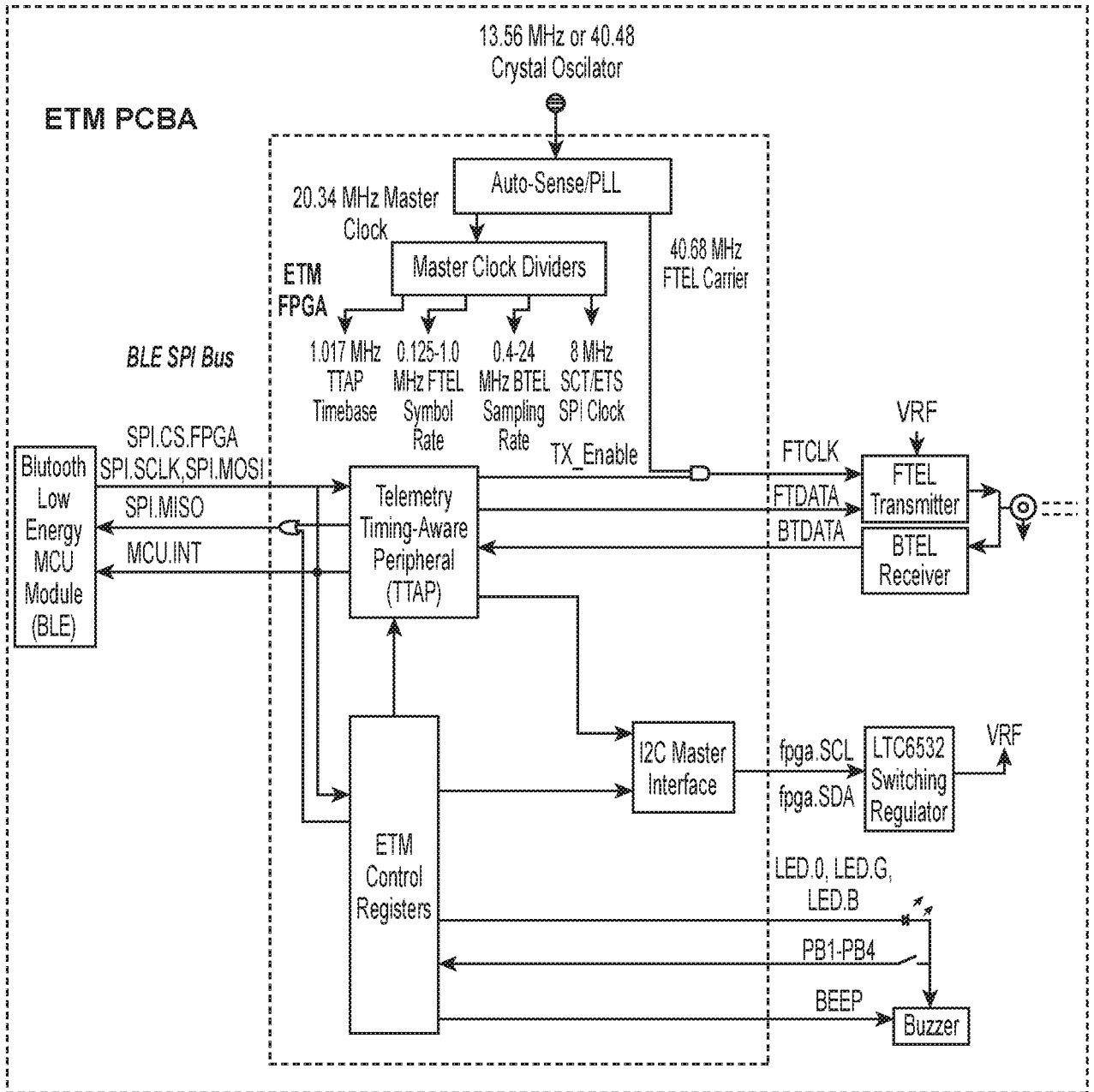

FIG. 18

Stimulation Control Table (SCT) Block Diagram



ETM FPGA and Surrounding System Block Diagram

FIG. 19

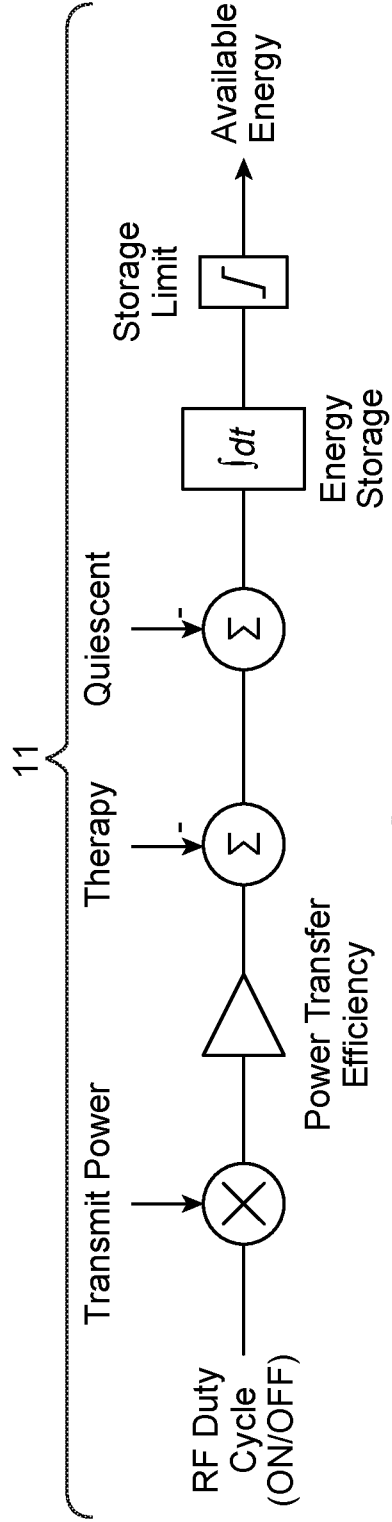

FIG. 20A

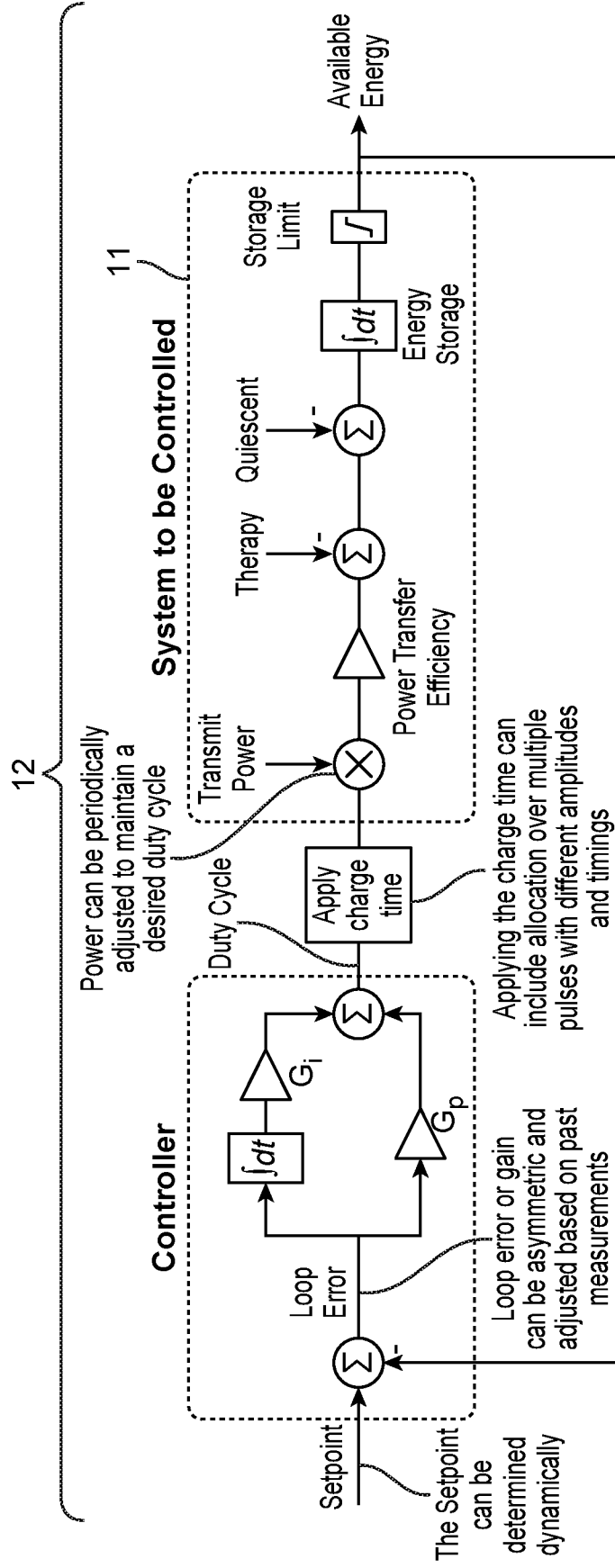

FIG. 20B

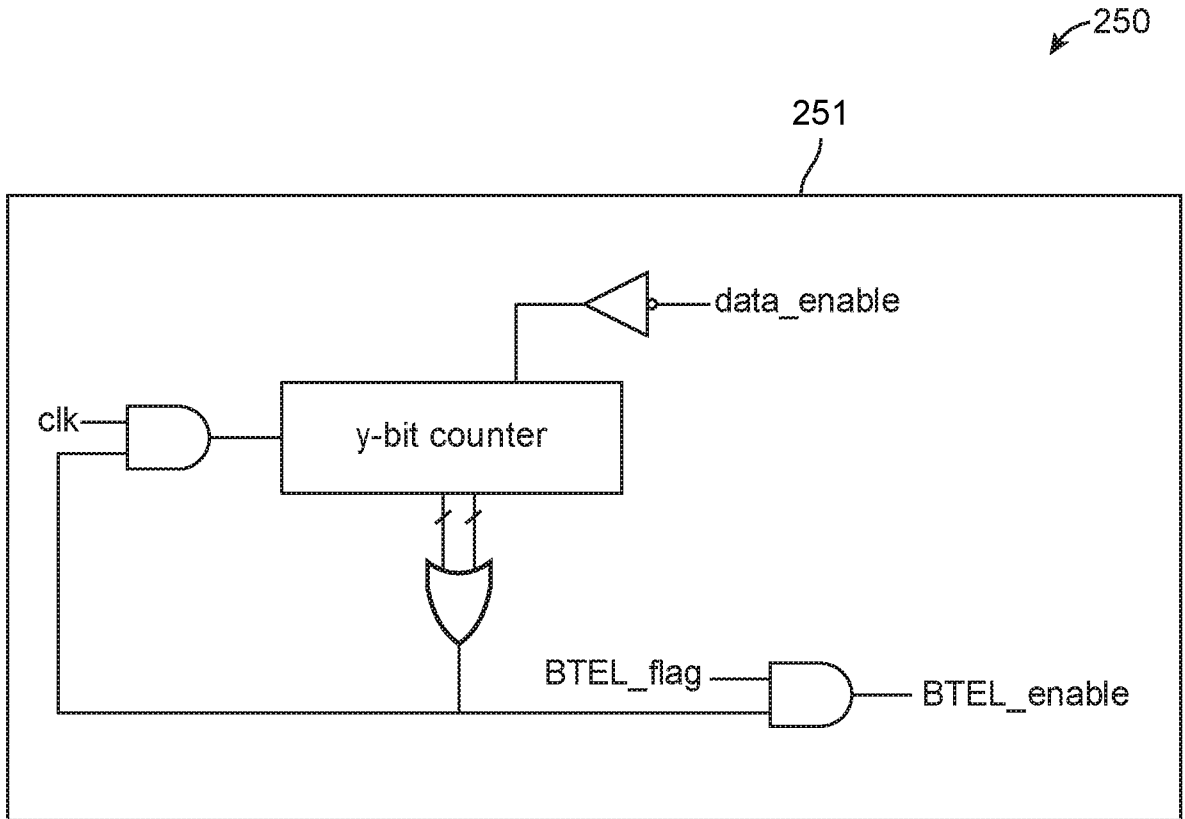

FIG. 21

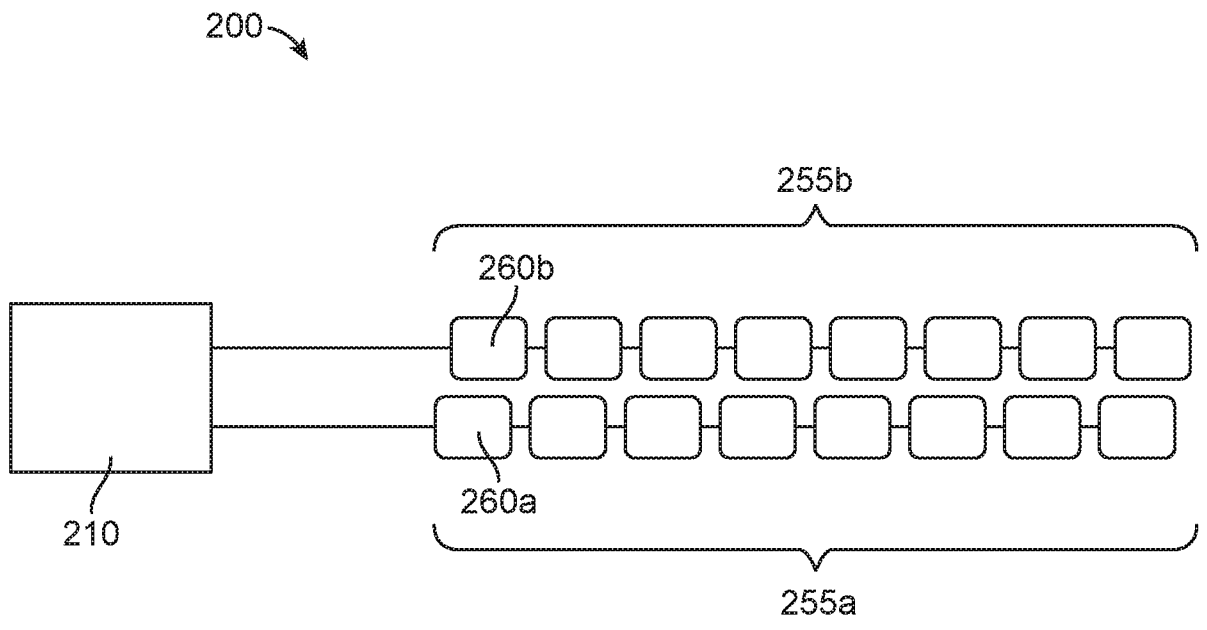

FIG. 22A

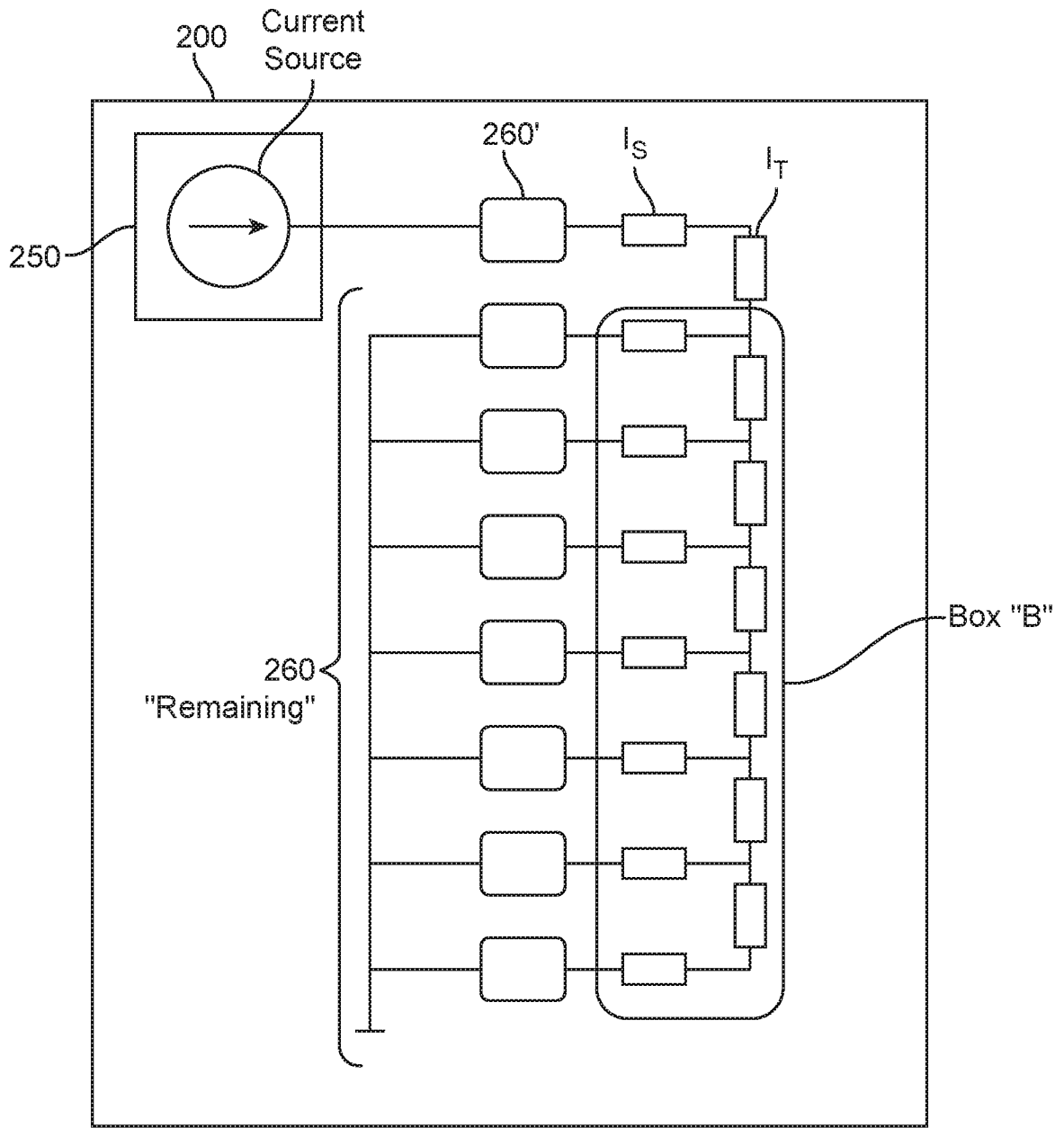

FIG. 22B

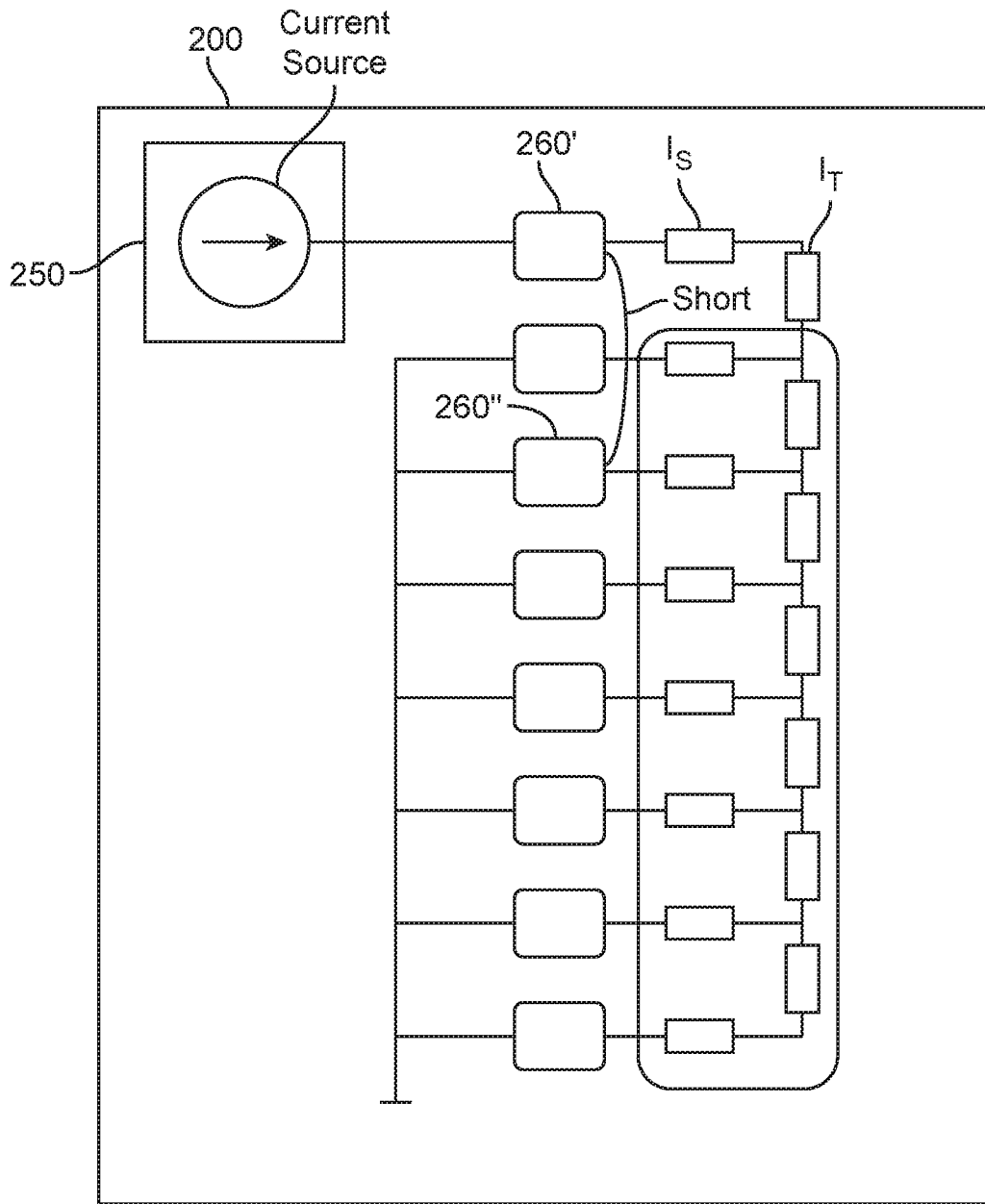

FIG. 22C

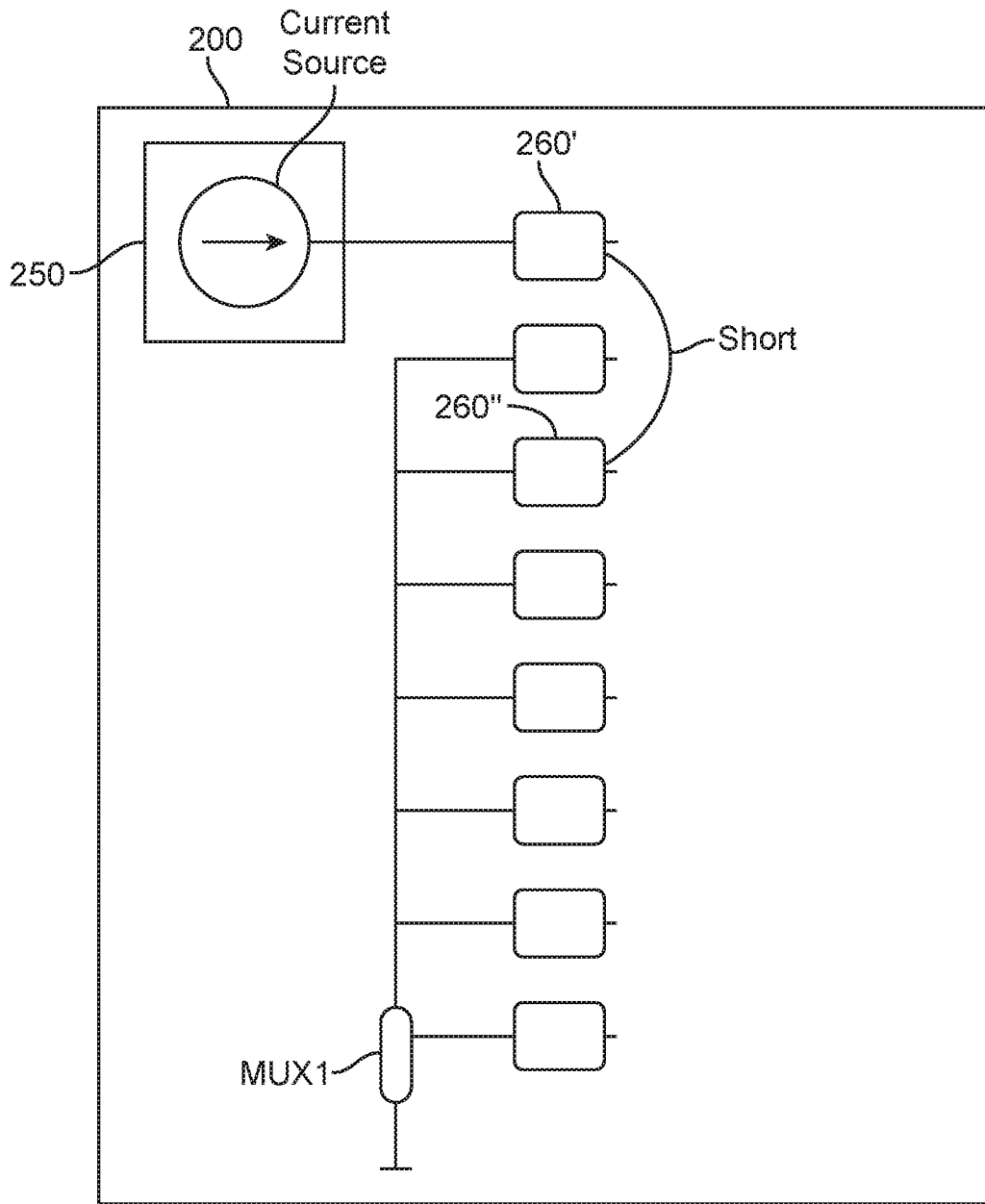

FIG. 22D

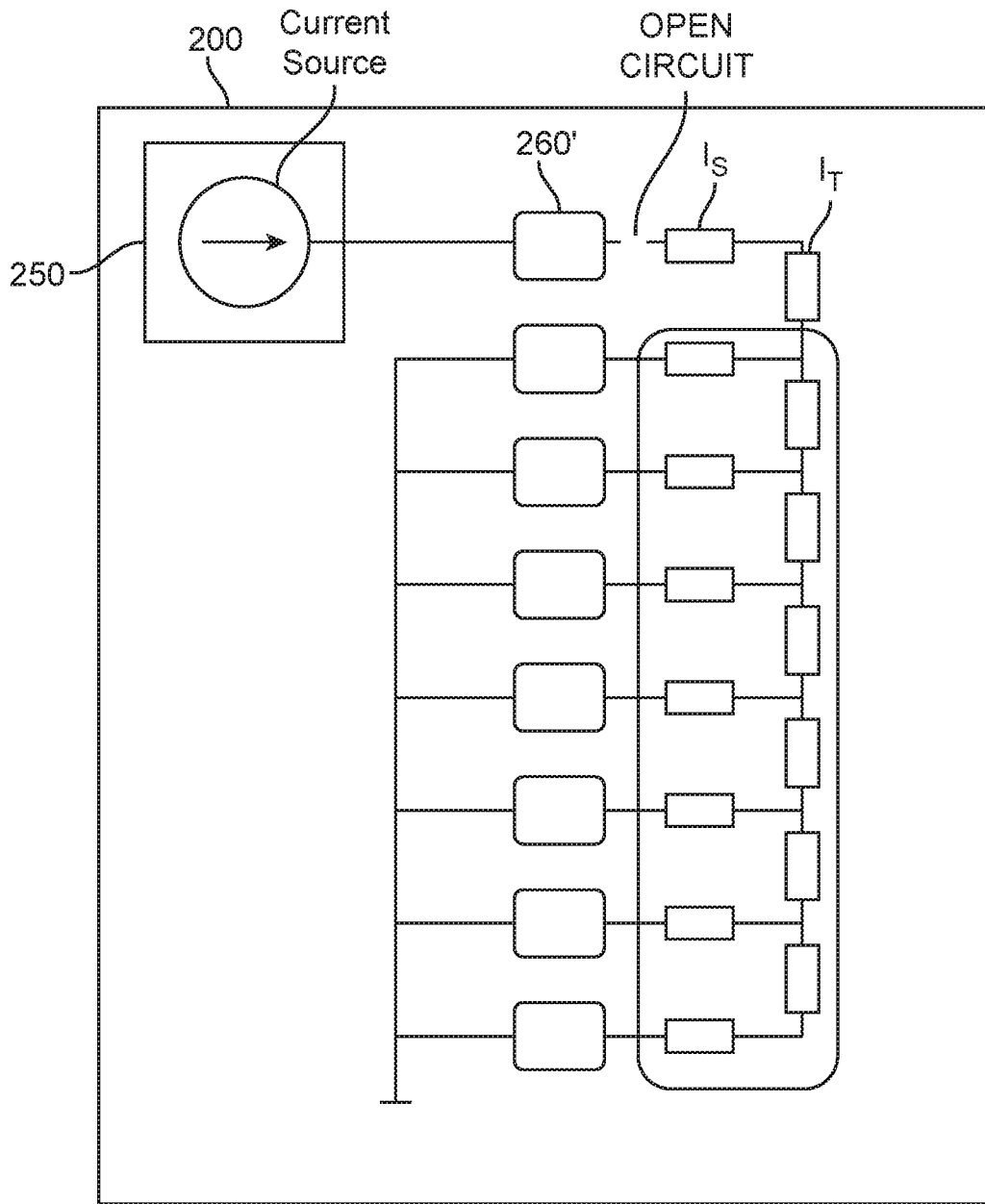

FIG. 22E

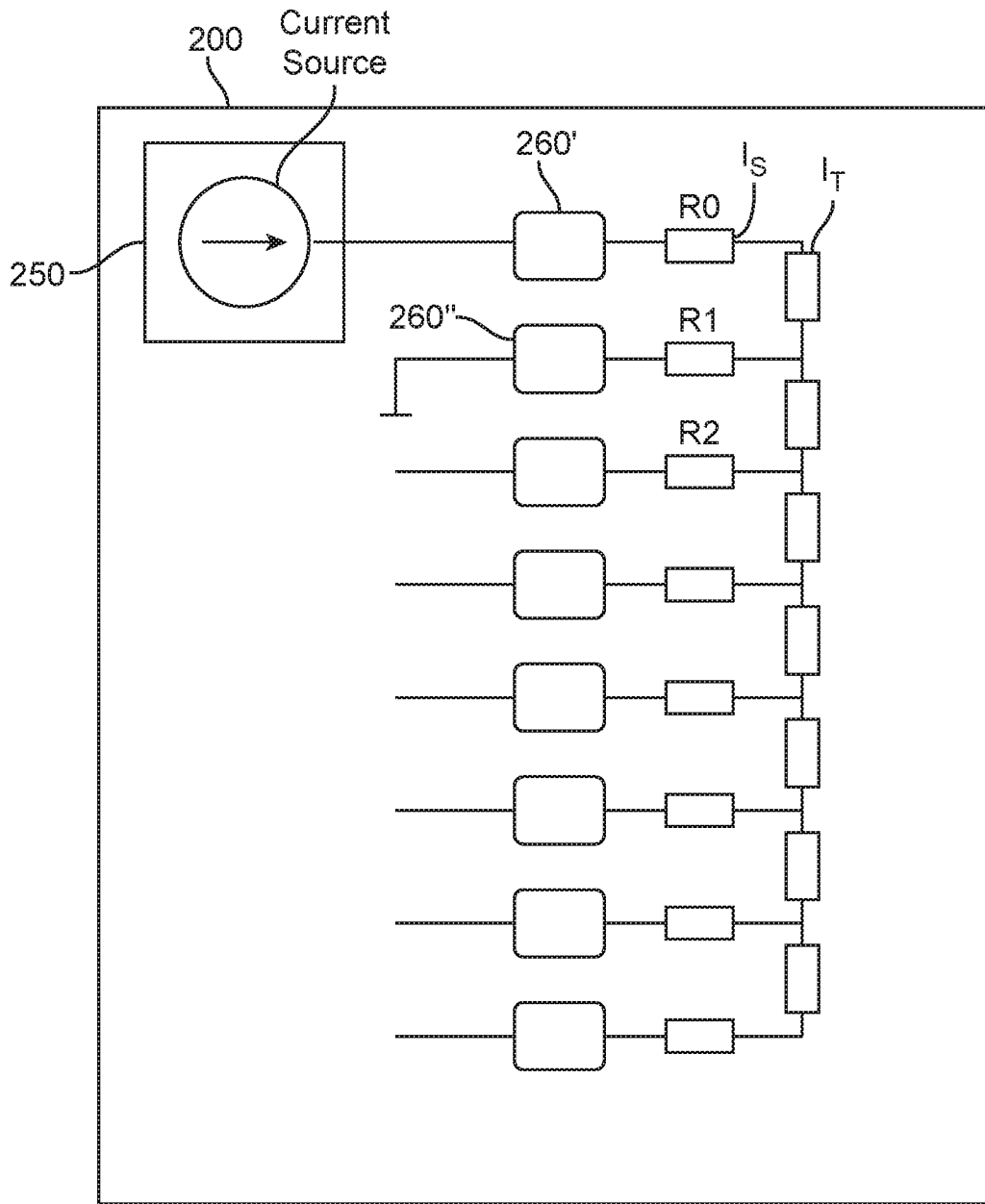

FIG. 22F

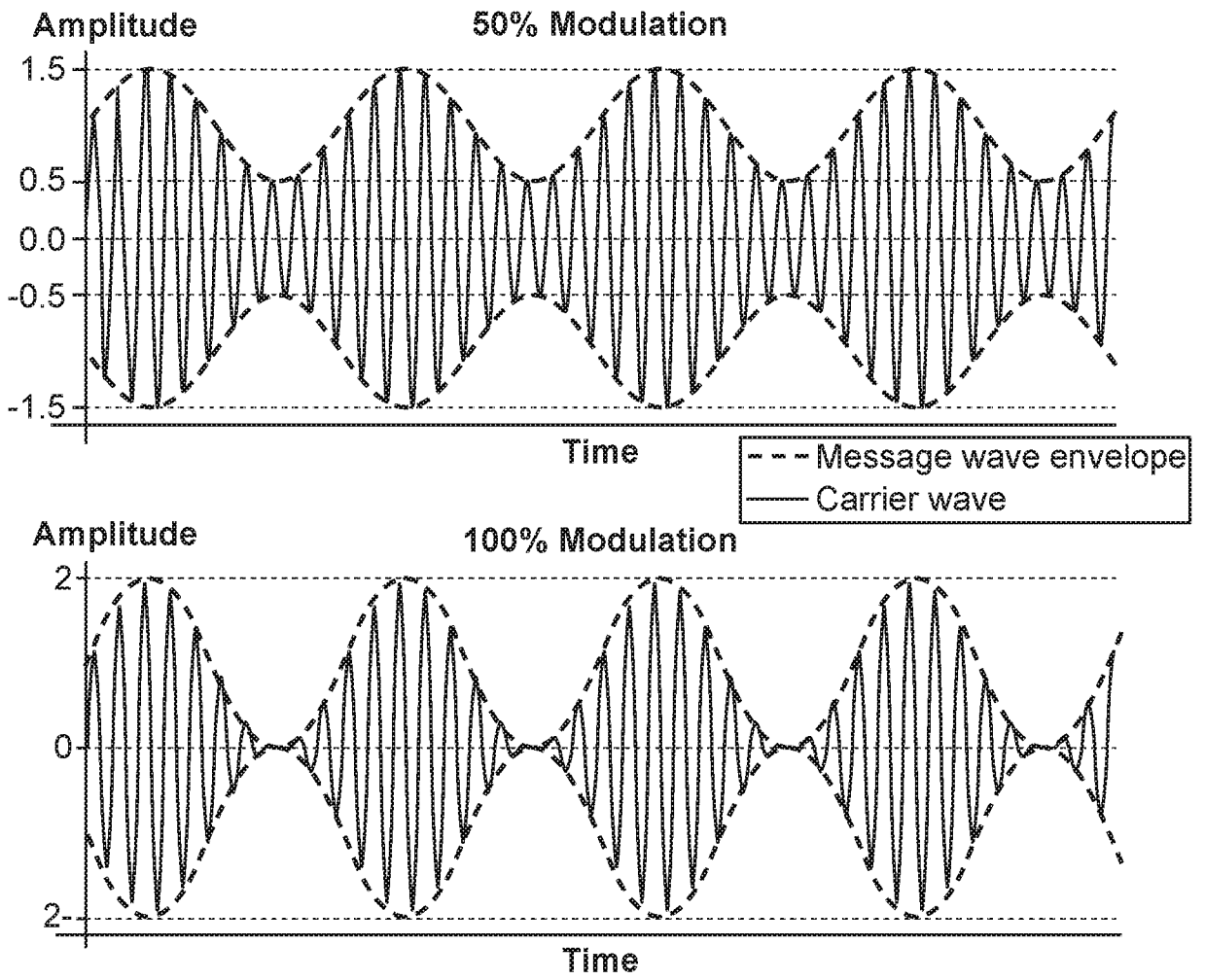

FIG. 23

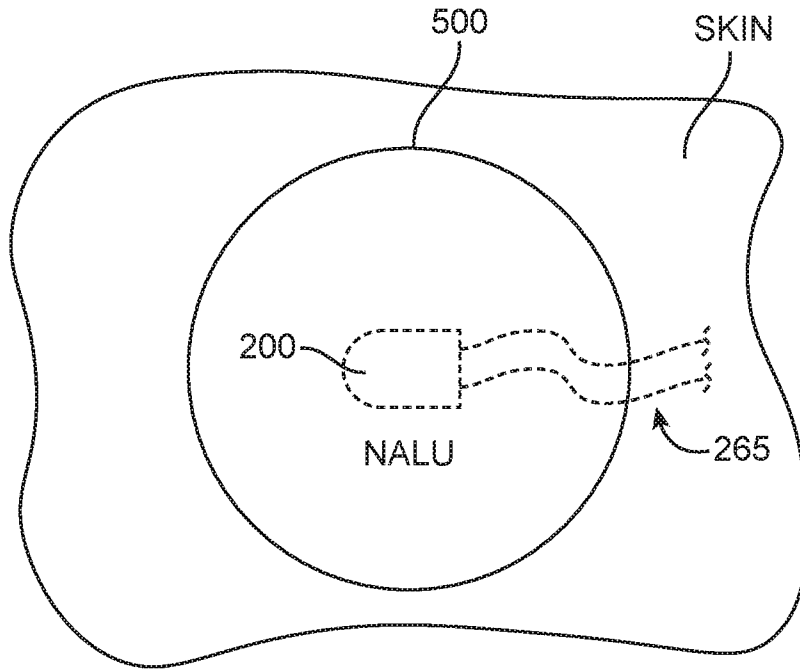

FIG. 24A

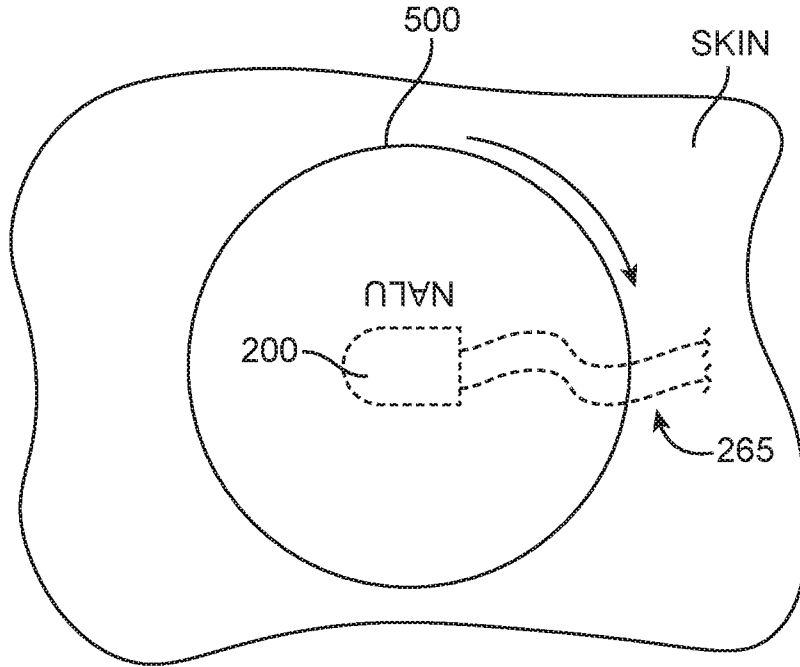

FIG. 24B

255b

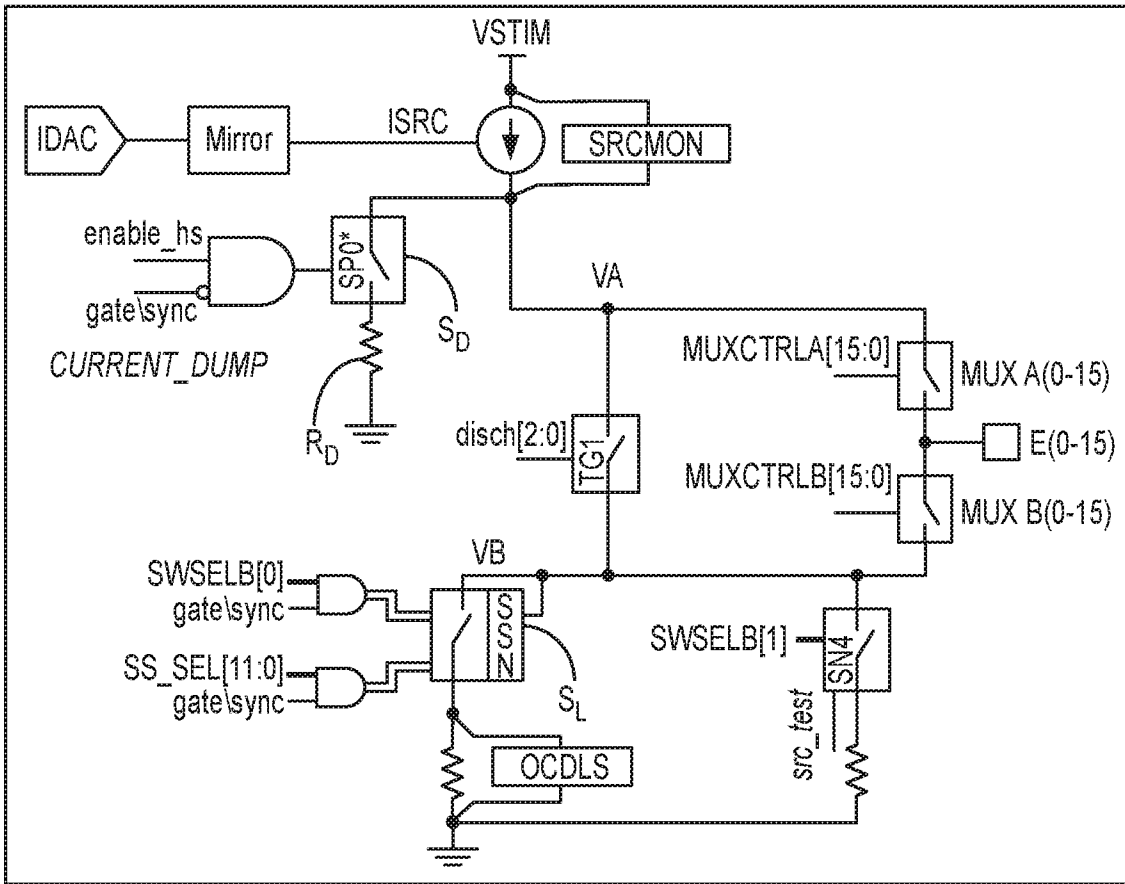

FIG. 25A

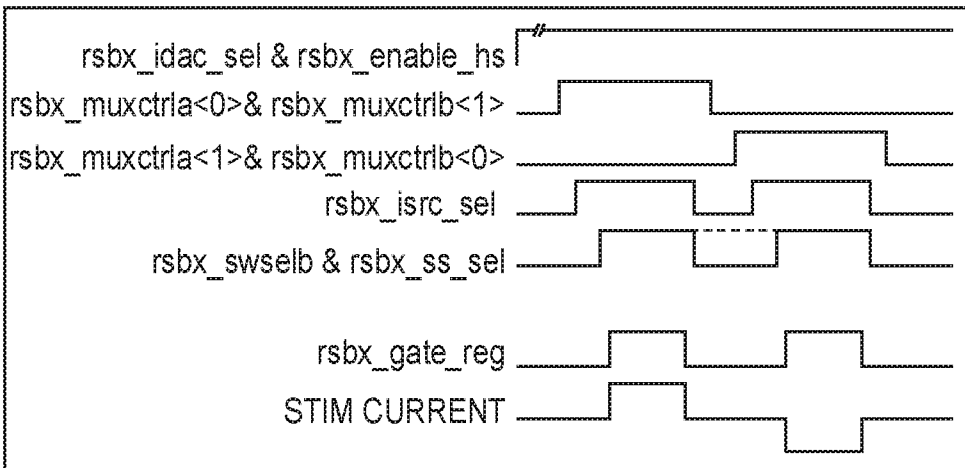

FIG. 25B

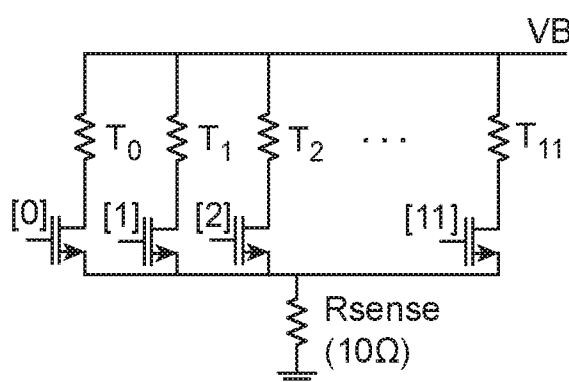

FIG. 25C

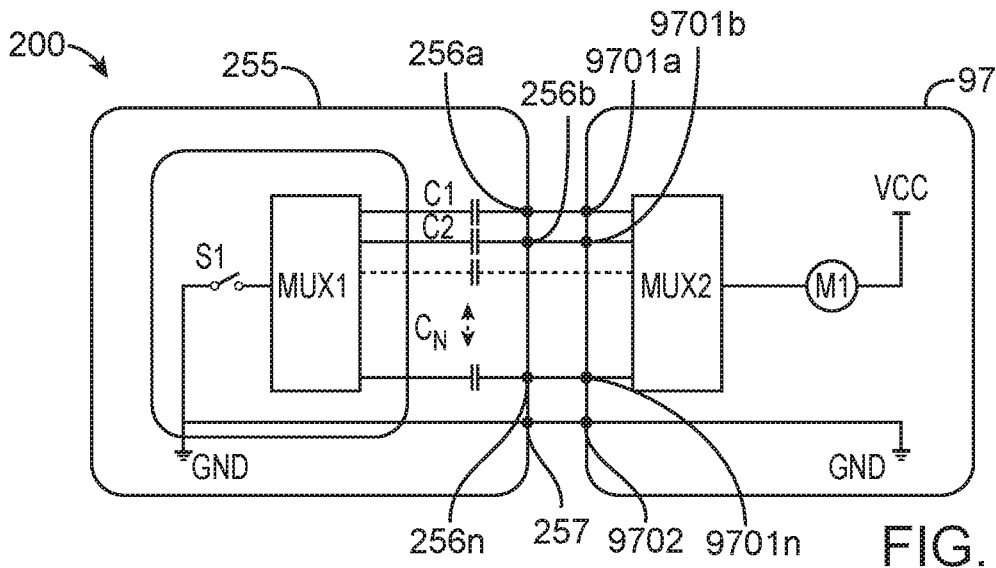

FIG. 26A

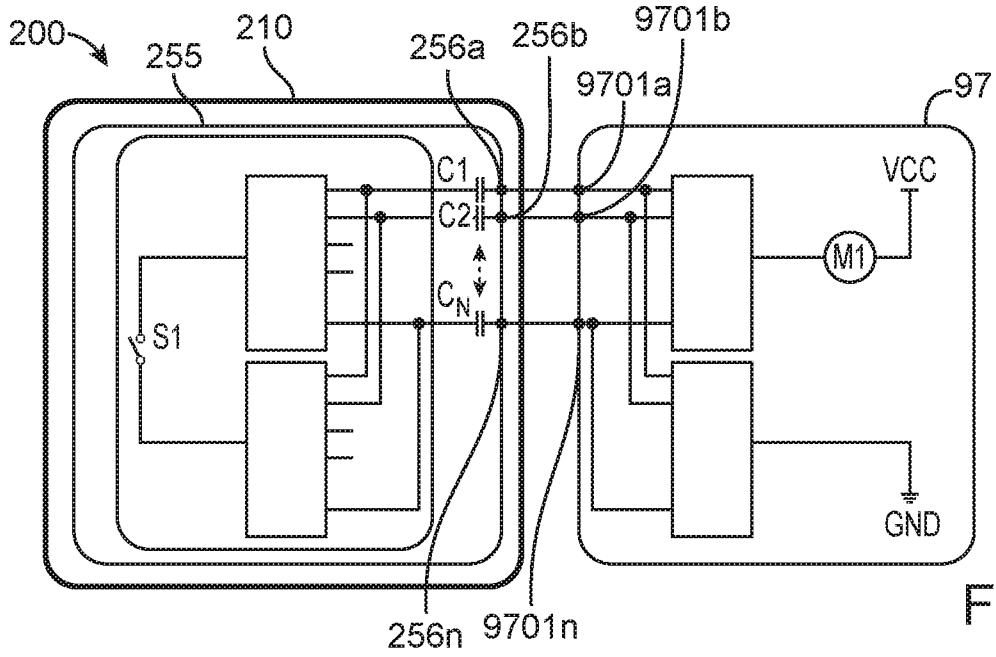

FIG. 26B

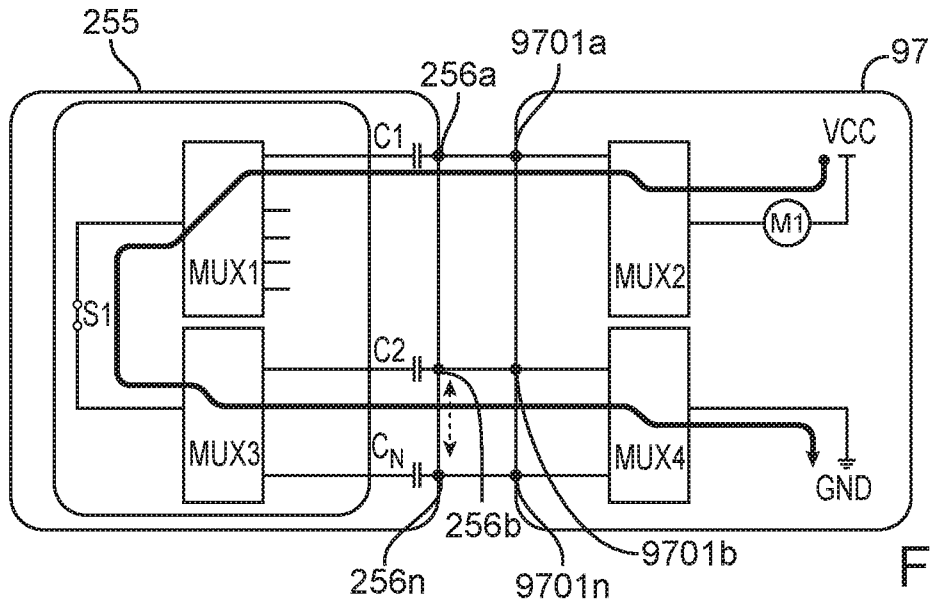

FIG. 26C

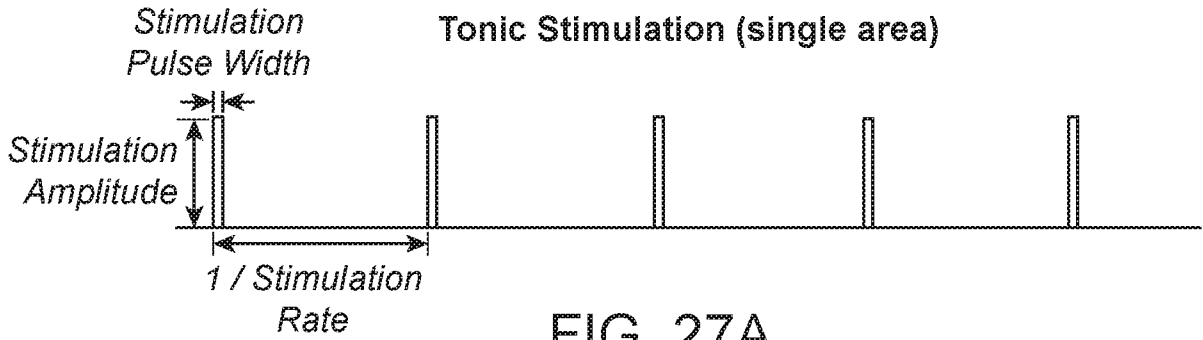

FIG. 27A

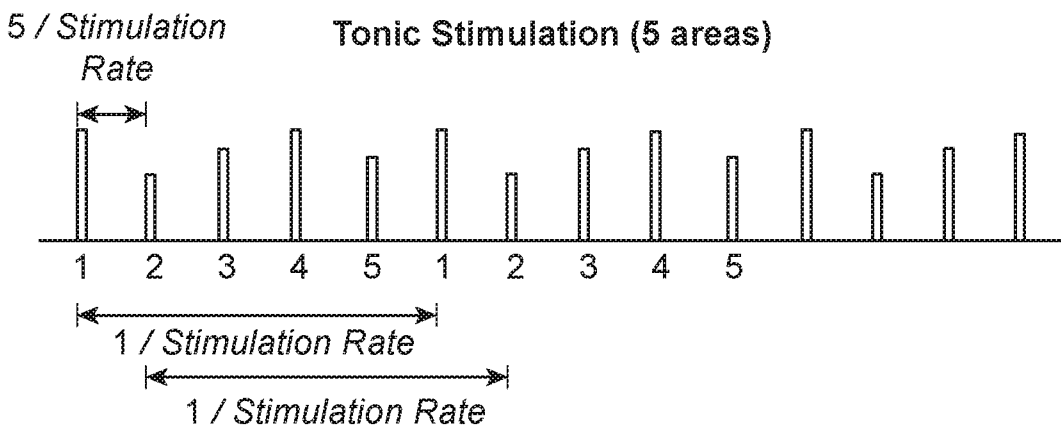

FIG. 27B

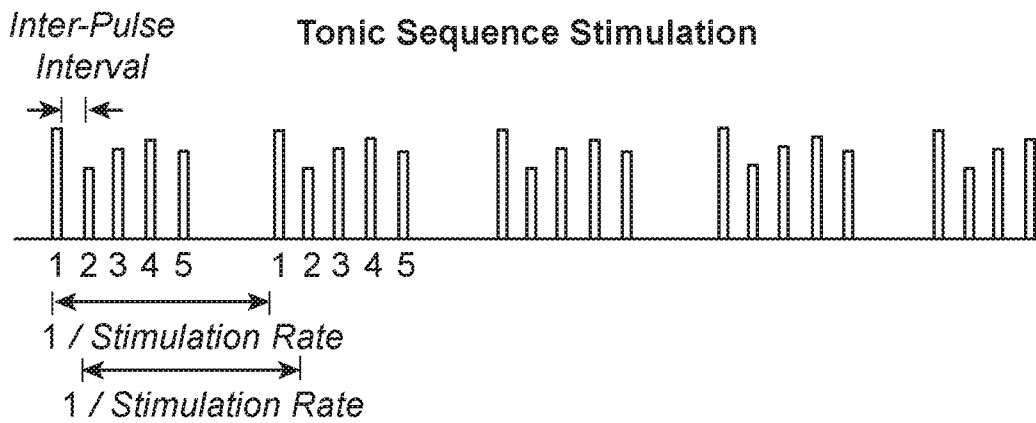

FIG. 27C

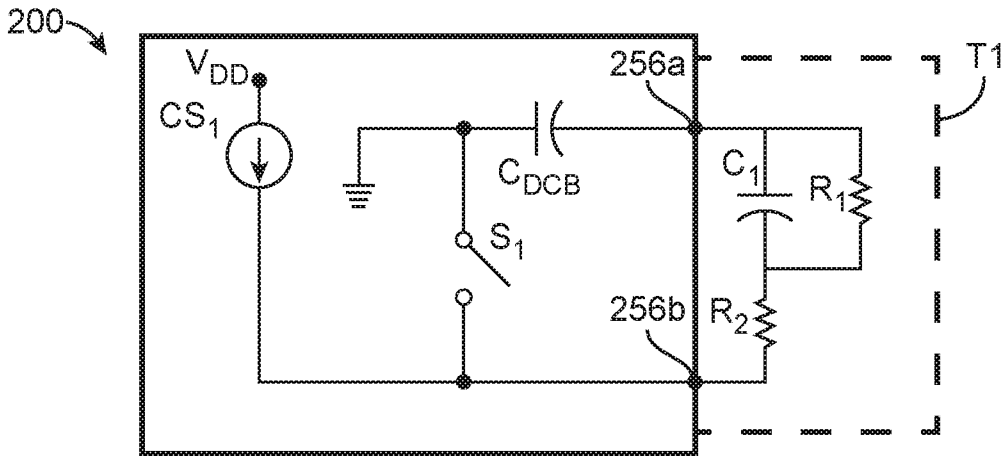

FIG. 28A

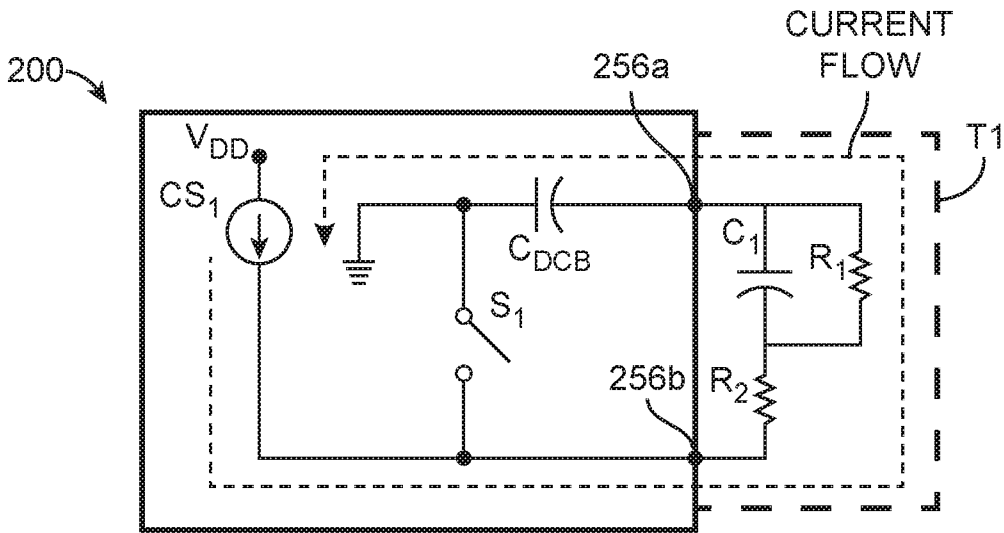

FIG. 28B

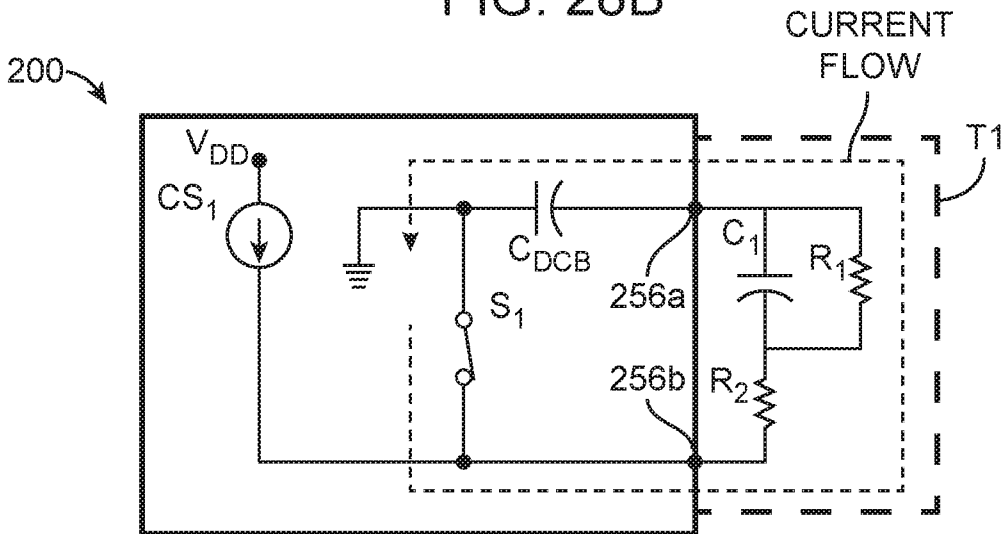

FIG. 28C

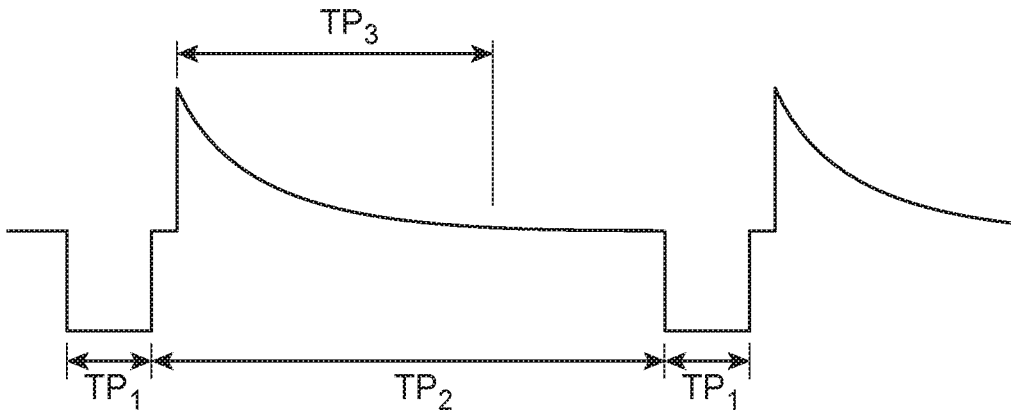

FIG. 28D

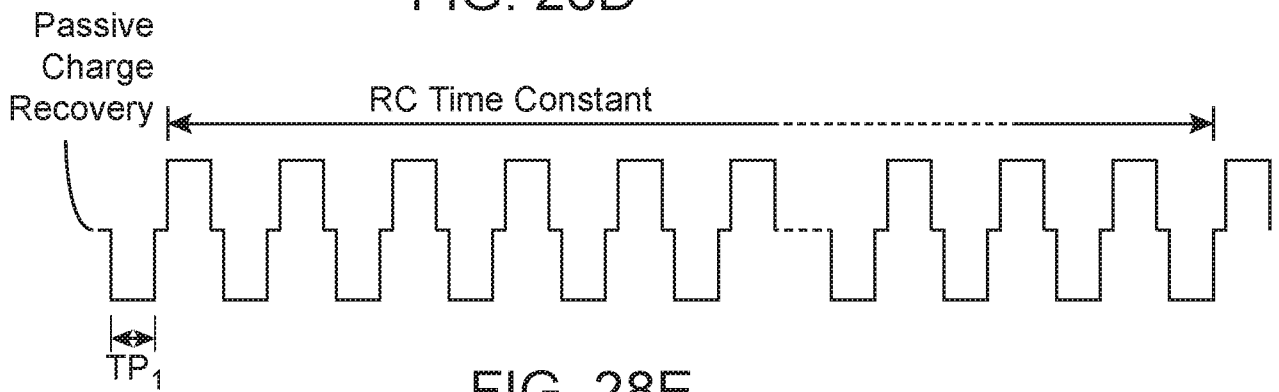

FIG. 28E

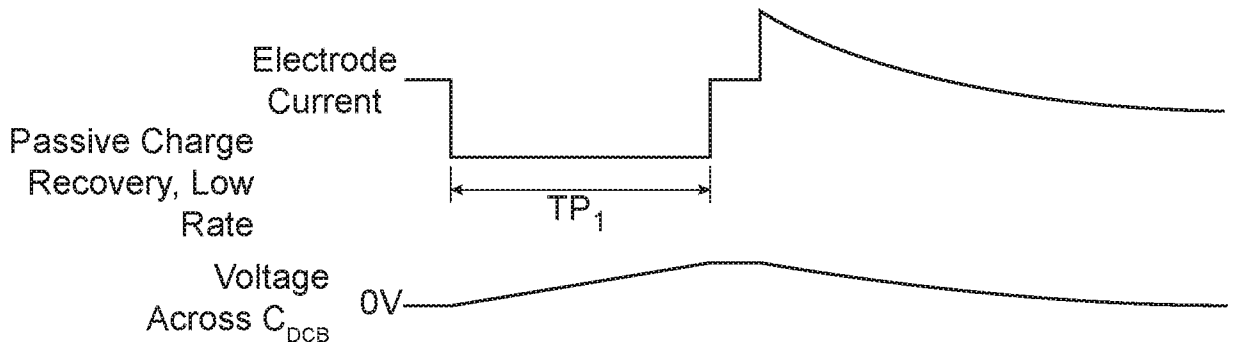

FIG. 28F

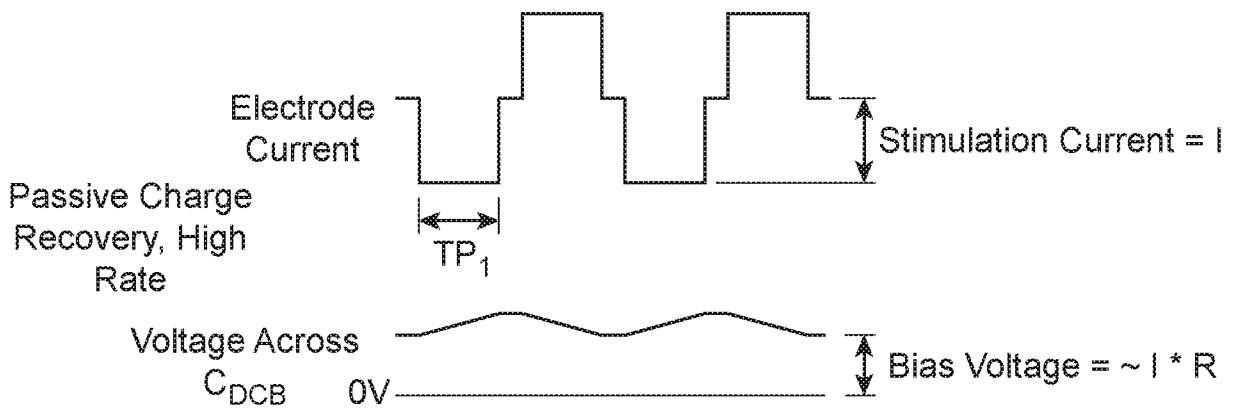

FIG. 28G