

(12) STANDARD PATENT APPLICATION (11) Application No. **AU 2026201822 A1**
(19) AUSTRALIAN PATENT OFFICE

(54) Title
TRANSFORM-BASED IMAGE CODING METHOD, AND APPARATUS THEREFOR

(51) International Patent Classification(s)
H04N 19/60 (2014.01) **H04N 19/18** (2014.01)
H04N 19/119 (2014.01) **H04N 19/186** (2014.01)
H04N 19/132 (2014.01) **H04N 19/70** (2014.01)
H04N 19/176 (2014.01)

(21) Application No: **2026201822** (22) Date of Filing: **2026.03.11**

(43) Publication Date: **2026.04.02**

(43) Publication Journal Date: **2026.04.02**

(62) Divisional of:
2024203027

(71) Applicant(s)
LG Electronics Inc.

(72) Inventor(s)
KOO, Moonmo;LIM, Jaehyun;KIM, Seunghwan;SALEHIFAR, Mehdi

(74) Agent / Attorney
**Dentons Patent Attorneys Australasia Limited, 18 Viaduct Harbour Avenue, Auckland
CBD, 1142, NZ**

ABSTRACT

An image decoding method according to the present document comprises: a residual coding step for parsing residual information received in a residual coding level and arranging transform coefficients for a current block according to a predetermined scanning order; a step for deriving residual samples by applying at least one of LFNST or MTS to the transform coefficients; and a step for generating a reconstructed picture on the basis of the residual samples, wherein the LFNST is performed on the basis of an LFNST index indicating an LFNST kernel, the MTS is performed on the basis of an MTS index indicating an MTS kernel, the LFNST index and the MTS index are signaled in a coding unit level, and the MTS index is signaled immediately after the signaling of the LFNST index.

**TRANSFORM-BASED IMAGE CODING METHOD, AND APPARATUS
THEREFOR**

TECHNICAL FIELD

[1] The present disclosure relates to an image coding technique and, more particularly, to a method and an apparatus for coding an image based on transform in an image coding system.

BACKGROUND

[2] Nowadays, the demand for high-resolution and high-quality images/videos such as 4K, 8K or more ultra high definition (UHD) images/videos has been increasing in various fields. As the image/video data becomes higher resolution and higher quality, the transmitted information amount or bit amount increases as compared to the conventional image data. Therefore, when image data is transmitted using a medium such as a conventional wired/wireless broadband line or image/video data is stored using an existing storage medium, the transmission cost and the storage cost thereof are increased.

[3] Further, nowadays, the interest and demand for immersive media such as virtual reality (VR), artificial reality (AR) content or hologram, or the like is increasing, and broadcasting for images/videos having image features different from those of real images, such as a game image is increasing.

[4] Accordingly, there is a need for a highly efficient image/video compression technique for effectively compressing and transmitting or storing, and reproducing information of high resolution and high quality images/videos having various features as described above.

[5] It is desired to address or ameliorate one or more disadvantages or limitations associated with the prior art, provide an image decoding method performed by a decoding apparatus, an image encoding method performed by an encoding apparatus, a computer-

readable digital storage medium that stores indication information to cause an image decoding method to be performed, or to at least provide the public with a useful alternative.

SUMMARY

[6] A technical aspect of the present disclosure may be to provide a method and an apparatus for increasing image coding efficiency.

[7] Another technical aspect of the present disclosure may be to provide a method and an apparatus for increasing efficiency in transform index coding.

[8] Still another technical aspect of the present disclosure may be to provide an image coding method and apparatus using LFNST and MTS.

[9] Still another technical aspect of the present disclosure may be to provide an image coding method and apparatus for LFNST index and MTS index signaling.

[10] According to an embodiment of the present disclosure, there is provided an image decoding method performed by a decoding apparatus. The method may include: performing residual coding of arranging transform coefficients for a current block according to a predetermined scan order by parsing residual information received in a residual coding level; deriving residual samples by applying at least one of an LFNST or an MTS to the transform coefficients; and generating a reconstructed picture based on the residual samples, wherein the LFNST may be performed based on an LFNST index indicating an LFNST kernel, the MTS may be performed based on an MTS index indicating an MTS kernel, the LFNST index and the MTS index may be signaled in a coding unit level, and the MTS index may be signaled immediately after the LFNST index is signaled.

[11] When a tree type of the current block is a single-tree type, the LFNST index may be parsed after the residual coding for a luma block and a chroma block of the current block is performed.

[12] When a tree type of the current block is a dual-tree type and a chroma component is coded, the LFNST index may be parsed after the residual coding for a Cb component and a Cr component of the chroma block is performed.

[13] When the current block is partitioned into a plurality of sub-partition blocks, the LFNST index may be parsed after the residual coding for the plurality of sub-partition blocks is performed.

[14] When the current block is partitioned into the plurality of sub-partition blocks, the LFNST index may be parsed regardless of whether the transform coefficients exist in a region excluding a DC position of each of the plurality of sub-partition blocks.

[15] The step of performing the residual coding may comprise: deriving a first variable indicating whether the transform coefficients exist in a region excluding a DC position of the current block; and deriving a second variable indicating whether the transform coefficients exist in a second region excluding a top-left first region of the current block or the sub-partition blocks into which the current block is partitioned, and the LFNST index may be parsed when the transform coefficients exist in the region excluding the DC position and the transform coefficients do not exist in the second region.

[16] The step of performing the residual coding may further comprise deriving a third variable indicating whether the transform coefficients exist in a region excluding a top-left 16 x 16 region of the current block, and the MTS index may be parsed when the transform coefficients do not exist in the region excluding the 16 x 16 region.

[17] According to another embodiment of the present disclosure, there is provided an image encoding method performed by an encoding apparatus. The method may include: deriving prediction samples for a current block; deriving residual samples for the current block based on the prediction samples; performing a transform coefficient derivation operation of deriving transform coefficients for a current block by applying at least one of an LFNST or an MTS to residual samples and arranging the transform coefficients according to a predetermined scan

order; encoding at least one of an LFNST index indicating an LFNST kernel or an MTS index indicating an MTS kernel; and constructing and outputting image information so that the LFNST index and the MTS index are signaled in a coding unit level and the MTS index is signaled immediately after the LFNST index is signaled.

[18] When a tree type of the current block is a single-tree type, the LFNST index may be encoded after the transform coefficient derivation operation for a luma block and a chroma block of the current block is performed.

[19] When a tree type of the current block is a dual-tree type and a chroma component is coded, the LFNST index may be encoded after the transform coefficient derivation operation for a Cb component and a Cr component of the chroma block is performed.

[20] When the current block is partitioned into a plurality of sub-partition blocks, the LFNST index may be encoded after the transform coefficient derivation operation for the plurality of sub-partition blocks is performed.

[21] When the current block is partitioned into the plurality of sub-partition blocks, the LFNST index may be encoded regardless of whether the transform coefficients exist in a region excluding a DC position of each of the sub-partition blocks.

[22] The step of performing the transform coefficient derivation operation may comprise: deriving a first variable indicating whether the transform coefficients exist in a region excluding a DC position of the current block; and deriving a second variable indicating whether the transform coefficients exist in a second region excluding a top-left first region of the current block or the sub-partition blocks into which the current block is partitioned, and wherein the LFNST index is encoded when the transform coefficients exist in the region excluding the DC position and the transform coefficients do not exist in the second region.

[23] The step of performing the transform coefficient derivation operation may further comprise deriving a third variable indicating whether the transform coefficients exist in a

region excluding a top-left 16 x 16 region of the current block, and wherein the MTS index is encoded when the transform coefficients do not exist in the region excluding the 16 x 16 region.

[24] According to another embodiment of the present disclosure, there is provided a computer-readable digital storage medium that stores indication information to cause an image decoding method to be performed, the decoding method comprising: performing residual coding of arranging transform coefficients for a current block according to a predetermined scan order by parsing residual information received in a residual coding level; deriving residual samples by applying at least one of an LFNST or an MTS to the transform coefficients; and generating a reconstructed picture based on the residual samples, wherein the LFNST is performed based on an LFNST index indicating an LFNST kernel, wherein the MTS is performed based on an MTS index indicating an MTS kernel, wherein the LFNST index and the MTS index are signaled in a coding unit level, and wherein the MTS index is signaled immediately after the LFNST index is signaled.

[25] According to still another embodiment of the present disclosure, there may be provided a digital storage medium that stores image data including encoded image information and a bitstream generated according to an image encoding method performed by an encoding apparatus.

[26] According to yet another embodiment of the present disclosure, there may be provided a digital storage medium that stores image data including encoded image information and a bitstream to cause a decoding apparatus to perform the image decoding method.

[27] According to the present disclosure, it may be possible to increase overall image/video compression efficiency.

[28] According to the present disclosure, it may be possible to increase efficiency in transform index coding.

[29] Still another technical aspect of the present disclosure may provide an image coding method and apparatus using LFNST and MTS.

[30] Still another technical aspect of the present disclosure may provide an image coding method and apparatus for LFNST index and MTS index signaling.

[31] The term “comprising” as used in the specification and claims means “consisting at least in part of.” When interpreting each statement in this specification that includes the term “comprising,” features other than that or those prefaced by the term may also be present. Related terms “comprise” and “comprises” are to be interpreted in the same manner.

[32] The reference in this specification to any prior publication (or information derived from it), or to any matter which is known, is not, and should not be taken as, an acknowledgement or admission or any form of suggestion that that prior publication (or information derived from it) or known matter forms part of the common general knowledge in the field of endeavour to which this specification.

BRIEF DESCRIPTION OF THE DRAWINGS

[33] FIG. 1 is a diagram schematically describing a configuration of a video/image encoding apparatus to which the present document may be applied.

[34] FIG. 2 is a diagram schematically describing a configuration of a video/image decoding apparatus to which the present document may be applied.

[35] FIG. 3 schematically illustrates a multiple transform technique according to an embodiment of the present disclosure.

[36] FIG. 4 exemplarily shows intra directional modes of 65 prediction directions.

[37] FIG. 5 is a diagram illustrating an RST according to an embodiment of the present disclosure.

[38] FIG. 6 is a diagram illustrating a sequence of arranging output data of a forward primary transformation into a one-dimensional vector according to an example.

[39] FIG. 7 is a diagram illustrating a sequence of arranging output data of a forward secondary transform into a two-dimensional block according to an example.

- [40] FIG. 8 is a diagram illustrating a block shape to which the LFNST is applied.
- [41] FIG. 9 is a diagram illustrating an arrangement of output data of a forward LFNST according to an example.
- [42] FIG. 10 shows that the number of output data for the forward LFNST is limited to a maximum of 16 according to an example.
- [43] FIG. 11 is a diagram illustrating the zero-out in a block to which the 4x4 LFNST is applied according to an example.
- [44] FIG. 12 is a diagram illustrating the zero-out in a block to which the 8x8 LFNST is applied according to an example.
- [45] FIG. 13 is a diagram illustrating the zero-out in a block to which the 8x8 LFNST is applied according to another example.
- [46] FIG. 14 is a diagram showing an example of a sub-block into which one coding block is divided.
- [47] FIG. 15 is a diagram showing another example of a sub-block into which one coding block is divided.
- [48] FIG. 16 is a diagram illustrating symmetry between an $M \times 2$ ($M \times 1$) block and a $2 \times M$ ($1 \times M$) block according to an example.
- [49] FIG. 17 is a diagram illustrating an example of transposing a $2 \times M$ block according to an example.
- [50] FIG. 18 shows a scanning order for an 8×2 or 2×8 region according to an example.
- [51] FIG. 19 is a diagram for explaining a method of decoding an image according to an example.
- [52] FIG. 20 is a diagram for explaining a method of encoding an image according to an example.
- [53] FIG. 21 schematically illustrates an example of a video/image coding system to which the present disclosure is applicable.

[54] FIG. 22 illustrates the structure of a content streaming system to which the present disclosure is applied.

DETAILED DESCRIPTION

[55] While the present disclosure may be susceptible to various modifications and include various embodiments, specific embodiments thereof have been shown in the drawings by way of example and will now be described in detail. However, this is not intended to limit the present disclosure to the specific embodiments disclosed herein. The terminology used herein is for the purpose of describing specific embodiments only, and is not intended to limit technical idea of the present disclosure. The singular forms may include the plural forms unless the context clearly indicates otherwise. The terms such as "include" and "have" are intended to indicate that features, numbers, steps, operations, elements, components, or combinations thereof used in the following description exist, and thus should not be understood as that the possibility of existence or addition of one or more different features, numbers, steps, operations, elements, components, or combinations thereof is excluded in advance.

[56] Meanwhile, each component on the drawings described herein is illustrated independently for convenience of description as to characteristic functions different from each other, and however, it is not meant that each component is realized by a separate hardware or software. For example, any two or more of these components may be combined to form a single component, and any single component may be divided into plural components. The embodiments in which components are combined and/or divided will belong to the scope of the patent right of the present disclosure as long as they do not depart from the essence of the present disclosure.

[57] Hereinafter, preferred embodiments of the present disclosure will be explained in more detail while referring to the attached drawings. In addition, the same reference signs are used

for the same components on the drawings, and repeated descriptions for the same components will be omitted.

[58] This document relates to video/image coding. For example, the method/example disclosed in this document may relate to a VVC (Versatile Video Coding) standard (ITU-T Rec. H.266), a next-generation video/image coding standard after VVC, or other video coding related standards (e.g. , HEVC (High Efficiency Video Coding) standard (ITU-T Rec. H.265), EVC (essential video coding) standard, AVS2 standard, etc.).

[59] In this document, a variety of embodiments relating to video/image coding may be provided, and, unless specified to the contrary, the embodiments may be combined to each other and be performed.

[60] In this document, a video may mean a set of a series of images over time. Generally a picture means a unit representing an image at a specific time zone, and a slice/tile is a unit constituting a part of the picture. The slice/tile may include one or more coding tree units (CTUs). One picture may be constituted by one or more slices/tiles. One picture may be constituted by one or more tile groups. One tile group may include one or more tiles.

[61] A pixel or a pel may mean a smallest unit constituting one picture (or image). Also, 'sample' may be used as a term corresponding to a pixel. A sample may generally represent a pixel or a value of a pixel, and may represent only a pixel/pixel value of a luma component or only a pixel/pixel value of a chroma component. Alternatively, the sample may refer to a pixel value in the spatial domain, or when this pixel value is converted to the frequency domain, it may refer to a transform coefficient in the frequency domain.

[62] A unit may represent the basic unit of image processing. The unit may include at least one of a specific region and information related to the region. One unit may include one luma block and two chroma (e.g., cb, cr) blocks. The unit and a term such as a block, an area, or the like may be used in place of each other according to circumstances. In a general case, an $M \times$

N block may include a set (or an array) of samples (or sample arrays) or transform coefficients consisting of M columns and N rows.

[63] In this document, the term "/" and "," should be interpreted to indicate "and/or." For instance, the expression "A/B" may mean "A and/or B." Further, "A, B" may mean "A and/or B." Further, "A/B/C" may mean "at least one of A, B, and/or C." Also, "A/B/C" may mean "at least one of A, B, and/or C."

[64] Further, in the document, the term "or" should be interpreted to indicate "and/or." For instance, the expression "A or B" may include 1) only A, 2) only B, and/or 3) both A and B. In other words, the term "or" in this document should be interpreted to indicate "additionally or alternatively."

[65] In the present disclosure, "at least one of A and B" may mean "only A", "only B", or "both A and B". In addition, in the present disclosure, the expression "at least one of A or B" or "at least one of A and/or B" may be interpreted as "at least one of A and B".

[66] In addition, in the present disclosure, "at least one of A, B, and C" may mean "only A", "only B", "only C", or "any combination of A, B, and C". In addition, "at least one of A, B, or C" or "at least one of A, B, and/or C" may mean "at least one of A, B, and C".

[67] In addition, a parenthesis used in the present disclosure may mean "for example". Specifically, when indicated as "prediction (intra prediction)", it may mean that "intra prediction" is proposed as an example of "prediction". In other words, the "prediction" of the present disclosure is not limited to "intra prediction", and "intra prediction" may be proposed as an example of "prediction". In addition, when indicated as "prediction (i.e., intra prediction)", it may also mean that "intra prediction" is proposed as an example of "prediction".

[68] Technical features individually described in one figure in the present disclosure may be individually implemented or may be simultaneously implemented.

[69] FIG. 1 is a diagram schematically illustrating a configuration of a video/image encoding apparatus applicable to embodiments of this document. Hereinafter, what is referred to as the video encoding apparatus may include the image encoding apparatus.

[70] Referring to FIG. 1, the encoding apparatus 100 may include and be configured with an image partitioner 110, a predictor 120, a residual processor 130, an entropy encoder 140, an adder 150, a filter 160, and a memory 170. The predictor 120 may include an inter predictor 121 and an intra predictor 122. The residual processor 130 may include a transformer 132, a quantizer 133, a dequantizer 134, and an inverse transformer 135. The residual processor 130 may further include a subtractor 131. The adder 150 may be referred to as a reconstructor or reconstructed block generator. The image partitioner 110, the predictor 120, the residual processor 130, the entropy encoder 140, the adder 150, and the filter 160, which have been described above, may be configured by one or more hardware components (e.g., encoder chipsets or processors) according to an embodiment. Further, the memory 170 may include a decoded picture buffer (DPB), and may be constituted by a digital storage medium. The hardware component may further include the memory 170 as an internal/external component.

[71] The image partitioner 110 may partition an input image (or a picture or a frame) input to the encoding apparatus 100 into one or more processing units. As one example, the processing unit may be called a coding unit (CU). In this case, starting with a coding tree unit (CTU) or the largest coding unit (LCU), the coding unit may be recursively partitioned according to the Quad-tree binary-tree ternary-tree (QTBTBT) structure. For example, one coding unit may be divided into a plurality of coding units of a deeper depth based on the quad-tree structure, the binary-tree structure, and/or the ternary structure. In this case, for example, the quad-tree structure may be applied first and the binary-tree structure and/or the ternary structure may be applied later. Alternatively, the binary-tree structure may be applied first. The coding procedure according to the present disclosure may be performed based on the final coding unit which is not further partitioned. In this case, the maximum coding unit may be used

directly as a final coding unit based on coding efficiency according to the image characteristic. Alternatively, the coding unit may be recursively partitioned into coding units of a further deeper depth as needed, so that the coding unit of an optimal size may be used as a final coding unit. Here, the coding procedure may include procedures such as prediction, transform, and reconstruction, which will be described later. As another example, the processing unit may further include a prediction unit (PU) or a transform unit (TU). In this case, the prediction unit and the transform unit may be split or partitioned from the above-described final coding unit. The prediction unit may be a unit of sample prediction, and the transform unit may be a unit for deriving a transform coefficient and/or a unit for deriving a residual signal from a transform coefficient.

[72] The unit and a term such as a block, an area, or the like may be used in place of each other according to circumstances. In a general case, an $M \times N$ block may represent a set of samples or transform coefficients consisting of M columns and N rows. The sample may generally represent a pixel or a value of a pixel, and may represent only a pixel/pixel value of a luma component, or only a pixel/pixel value of a chroma component. The sample may be used as a term corresponding to a pixel or a pel of one picture (or image).

[73] In the encoding apparatus 100, a prediction signal (predicted block, prediction sample array) output from the inter predictor 121 or the intra predictor 122 may be subtracted from an input image signal (original block, original sample array) to generate a residual signal (residual block, residual sample array), and the generated residual signal is transmitted to the transformer 132. In this case, as shown, a unit of subtracting a prediction signal (predicted block, prediction sample array) from the input image signal (original block, original sample array) in the encoding apparatus 100 may be called the subtractor 131. The predictor may perform prediction on a processing target block (hereinafter, referred to as ‘current block’), and may generate a predicted block including prediction samples for the current block. The predictor may determine whether intra prediction or inter prediction is applied on a current block or CU

basis. As discussed later in the description of each prediction mode, the predictor may generate various prediction related information, such as prediction mode information, and transmit the generated information to the entropy encoder 140. The prediction related information may be encoded in the entropy encoder 140, and be output in the form of a bitstream.

[74] The intra predictor 122 may predict the current block by referring to samples in the current picture. The referred samples may be located in the neighbor of or apart from the current block according to the prediction mode. In the intra prediction, prediction modes may include a plurality of non-directional modes and a plurality of directional modes. The non-directional modes may include, for example, a DC mode and a planar mode. The directional mode may include, for example, 33 directional prediction modes or 65 directional prediction modes according to the degree of detail of the prediction direction. However, this is merely an example, and more or less directional prediction modes may be used depending on a setting. The intra predictor 122 may determine the prediction mode applied to the current block by using the prediction mode applied to the neighboring block.

[75] The inter predictor 121 may derive a predicted block for the current block based on a reference block (reference sample array) specified by a motion vector on a reference picture. At this time, in order to reduce the amount of motion information transmitted in the inter prediction mode, the motion information may be predicted on a block, subblock, or sample basis based on correlation of motion information between the neighboring block and the current block. The motion information may include a motion vector and a reference picture index. The motion information may further include inter prediction direction (L0 prediction, L1 prediction, Bi prediction, etc.) information. In the case of inter prediction, the neighboring block may include a spatial neighboring block existing in the current picture and a temporal neighboring block existing in the reference picture. The reference picture including the reference block and the reference picture including the temporal neighboring block may be same to each other or different from each other. The temporal neighboring block may be called a collocated reference

block, a collocated CU (colCU), and the like, and the reference picture including the temporal neighboring block may be called a collocated picture (colPic). For example, the inter predictor 121 may configure a motion information candidate list based on neighboring blocks and generate information indicating which candidate is used to derive a motion vector and/or a reference picture index of the current block. Inter prediction may be performed based on various prediction modes. For example, in the case of a skip mode and a merge mode, the inter predictor 121 may use motion information of the neighboring block as motion information of the current block. In the skip mode, unlike the merge mode, the residual signal may not be transmitted. In the case of the motion information prediction (motion vector prediction, MVP) mode, the motion vector of the neighboring block may be used as a motion vector predictor and the motion vector of the current block may be indicated by signaling a motion vector difference.

[76] The predictor 120 may generate a prediction signal based on various prediction methods to be described below. For example, for prediction on one block, the predictor may apply either intra prediction or inter prediction, and, as well, apply both of intra prediction and inter prediction at the same time. The latter may be called combined inter and intra prediction (CIIP). Further, the predictor may be based on an intra block copy (IBC) prediction mode, or a palette mode in order to perform prediction on a block. The IBC prediction mode or palette mode may be used for content image/video coding of a game or the like, such as screen content coding (SCC). The IBC basically performs prediction in a current picture, but it may be performed similarly to inter prediction in that it derives a reference block in a current picture. That is, the IBC may use at least one of inter prediction techniques described in the present document. The palette mode may be regarded as an example of intra coding or intra prediction. When the palette mode is applied, a sample value in a picture may be signaled based on information on a palette index and a palette table.

[77] The prediction signal generated through the predictor (including inter predictor 121 and/or the intra predictor 122) may be used to generate a reconstructed signal or to generate a residual signal. The transformer 132 may generate transform coefficients by applying a transform technique to the residual signal. For example, the transform technique may include at least one of a discrete cosine transform (DCT), a discrete sine transform (DST), a Karhunen-Loève transform (KLT), a graph-based transform (GBT), or a conditionally non-linear transform (CNT). Here, the GBT means transform obtained from a graph when relationship information between pixels is represented by the graph. The CNT means transform obtained based on a prediction signal generated using all previously reconstructed pixels. In addition, the transform process may be applied to square pixel blocks of the same size, or may be applied to non-square blocks of varying sizes.

[78] The quantizer 133 may quantize the transform coefficients and transmit them to the entropy encoder 140, and the entropy encoder 140 may encode the quantized signal (information on the quantized transform coefficients) and output the encoded signal in a bitstream. The information on the quantized transform coefficients may be referred to as residual information. The quantizer 133 may rearrange block type quantized transform coefficients into a one-dimensional vector form based on a coefficient scan order, and generate information on the quantized transform coefficients based on the quantized transform coefficients of the one-dimensional vector form. The entropy encoder 140 may perform various encoding methods such as, for example, exponential Golomb, context-adaptive variable length coding (CAVLC), context-adaptive binary arithmetic coding (CABAC), and the like. The entropy encoder 140 may encode information necessary for video/image reconstruction other than quantized transform coefficients (e.g. values of syntax elements, etc.) together or separately. Encoded information (e.g., encoded video/image information) may be transmitted or stored on a unit basis of a network abstraction layer (NAL) in the form of a bitstream. The video/image information may further include information on various parameter sets such as an

adaptation parameter set (APS), a picture parameter set (PPS), a sequence parameter set (SPS), a video parameter set (VPS) or the like. Further, the video/image information may further include general constraint information. In the present document, information and/or syntax elements which are transmitted/signaled to the decoding apparatus from the encoding apparatus may be incorporated in video/image information. The video/image information may be encoded through the above-described encoding procedure, and be incorporated in the bitstream. The bitstream may be transmitted through a network, or stored in a digital storage medium. Here, the network may include a broadcast network, a communication network and/or the like, and the digital storage medium may include various storage media such as USB, SD, CD, DVD, Blu-ray, HDD, SSD, and the like. A transmitter (not shown) which transmits a signal output from the entropy encoder 140 and/or a storage (not shown) which stores it may be configured as an internal/external element of the encoding apparatus 100, or the transmitter may be included in the entropy encoder 140.

[79] Quantized transform coefficients output from the quantizer 133 may be used to generate a prediction signal. For example, by applying dequantization and inverse transform to quantized transform coefficients through the dequantizer 134 and the inverse transformer 135, the residual signal (residual block or residual samples) may be reconstructed. The adder 155 adds the reconstructed residual signal to a prediction signal output from the inter predictor 121 or the intra predictor 122, so that a reconstructed signal (reconstructed picture, reconstructed block, reconstructed sample array) may be generated. When there is no residual for a processing target block as in a case where the skip mode is applied, the predicted block may be used as a reconstructed block. The adder 150 may be called a reconstructor or a reconstructed block generator. The generated reconstruction signal may be used for intra prediction of a next processing target block in the current block, and as described later, may be used for inter prediction of a next picture through filtering.

[80] Meanwhile, in the picture encoding and/or reconstructing process, luma mapping with chroma scaling (LMCS) may be applied.

[81] The filter 160 may improve subjective/objective video quality by applying the filtering to the reconstructed signal. For example, the filter 160 may generate a modified reconstructed picture by applying various filtering methods to the reconstructed picture, and may store the modified reconstructed picture in the memory 170, specifically in the DPB of the memory 170. The various filtering methods may include, for example, deblocking filtering, sample adaptive offset, an adaptive loop filter, a bilateral filter or the like. As discussed later in the description of each filtering method, the filter 160 may generate various information relating to filtering, and transmit the generated information to the entropy encoder 140. The information on the filtering may be encoded in the entropy encoder 140 and output in the form of a bitstream.

[82] The modified reconstructed picture which has been transmitted to the memory 170 may be used as a reference picture in the inter predictor 121. Through this, the encoding apparatus can avoid prediction mismatch in the encoding apparatus 100 and a decoding apparatus when the inter prediction is applied, and can also improve coding efficiency.

[83] The memory 170 DPB may store the modified reconstructed picture in order to use it as a reference picture in the inter predictor 121. The memory 170 may store motion information of a block in the current picture, from which motion information has been derived (or encoded) and/or motion information of blocks in an already reconstructed picture. The stored motion information may be transmitted to the inter predictor 121 to be utilized as motion information of a neighboring block or motion information of a temporal neighboring block. The memory 170 may store reconstructed samples of reconstructed blocks in the current picture, and transmit them to the intra predictor 122.

[84] FIG. 2 is a diagram schematically illustrating a configuration of a video/image decoding apparatus applicable to embodiments of this document.

[85] Referring to FIG. 2, the decoding apparatus 200 may include and be configured with an entropy decoder 210, a residual processor 220, a predictor 230, an adder 240, a filter 250 and a memory 260. The predictor 230 may include an inter predictor 232 and an intra predictor 231. The residual processor 220 may include a dequantizer 221 and an inverse transformer 221. The entropy decoder 210, the residual processor 220, the predictor 230, the adder 240, and the filter 250, which have been described above, may be configured by one or more hardware components (e.g., decoder chipsets or processors) according to an embodiment. Further, the memory 260 may include a decoded picture buffer (DPB), and may be constituted by a digital storage medium. The hardware component may further include the memory 260 as an internal/external component.

[86] When a bitstream including video/image information is input, the decoding apparatus 200 may reconstruct an image correspondingly to a process by which video/image information has been processed in the encoding apparatus of FIG. 1. For example, the decoding apparatus 200 may derive units/blocks based on information relating to block partition obtained from the bitstream. The decoding apparatus 200 may perform decoding by using a processing unit applied in the encoding apparatus. Therefore, the processing unit of decoding may be, for example, a coding unit, which may be partitioned along the quad-tree structure, the binary-tree structure, and/or the ternary-tree structure from a coding tree unit or a largest coding unit. One or more transform units may be derived from the coding unit. And, the reconstructed image signal decoded and output through the decoding apparatus 200 may be reproduced through a reproducer.

[87] The decoding apparatus 200 may receive a signal output from the encoding apparatus of FIG. 1 in the form of a bitstream, and the received signal may be decoded through the entropy decoder 210. For example, the entropy decoder 210 may parse the bitstream to derive information (e.g., video/image information) required for image reconstruction (or picture reconstruction). The video/image information may further include information on various

parameter sets such as an adaptation parameter set (APS), a picture parameter set (PPS), a sequence parameter set (SPS), a video parameter set (VPS) or the like. Further, the video/image information may further include general constraint information. The decoding apparatus may decode a picture further based on information on the parameter set and/or the general constraint information. In the present disclosure, signaled/received information and/or syntax elements, which will be described later, may be decoded through the decoding procedure and be obtained from the bitstream. For example, the entropy decoder 210 may decode information in the bitstream based on a coding method such as exponential Golomb encoding, CAVLC, CABAC, or the like, and may output a value of a syntax element necessary for image reconstruction and quantized values of a transform coefficient regarding a residual. More specifically, a CABAC entropy decoding method may receive a bin corresponding to each syntax element in a bitstream, determine a context model using decoding target syntax element information and decoding information of neighboring and decoding target blocks, or information of symbol/bin decoded in a previous step, predict bin generation probability according to the determined context model and perform arithmetic decoding of the bin to generate a symbol corresponding to each syntax element value. Here, the CABAC entropy decoding method may update the context model using information of a symbol/bin decoded for a context model of the next symbol/bin after determination of the context model. The prediction related information among informations decoded in the entropy decoder 210 may be provided to the predictor (inter predictor 232 and intra predictor 231), and residual values, that is, quantized transform coefficients, on which entropy decoding has been performed in the entropy decoder 210, and associated parameter information may be input to the residual processor 220. The residual processor 220 may derive a residual signal (residual block, residual samples, residual sample array). Further, information on filtering among informations decoded in the entropy decoder 210 may be provided to the filter 250. Meanwhile, a receiver (not shown) which receives a signal output from the encoding apparatus may further constitute the decoding apparatus 200

as an internal/external element, and the receiver may be a component of the entropy decoder 210. Meanwhile, the decoding apparatus according to the present document may be called a video/image/picture coding apparatus, and the decoding apparatus may be classified into an information decoder (video/image/picture information decoder) and a sample decoder (video/image/picture sample decoder). The information decoder may include the entropy decoder 210, and the sample decoder may include at least one of the dequantizer 221, the inverse transformer 222, the adder 240, the filter 250, the memory 260, the inter predictor 232, and the intra predictor 231.

[88] The dequantizer 221 may output transform coefficients by dequantizing the quantized transform coefficients. The dequantizer 221 may rearrange the quantized transform coefficients in the form of a two-dimensional block. In this case, the rearrangement may perform rearrangement based on an order of coefficient scanning which has been performed in the encoding apparatus. The dequantizer 221 may perform dequantization on the quantized transform coefficients using quantization parameter (e.g., quantization step size information), and obtain transform coefficients.

[89] The dequantizer 222 obtains a residual signal (residual block, residual sample array) by inverse transforming transform coefficients.

[90] The predictor may perform prediction on the current block, and generate a predicted block including prediction samples for the current block. The predictor may determine whether intra prediction or inter prediction is applied to the current block based on the information on prediction output from the entropy decoder 210, and specifically may determine an intra/inter prediction mode.

[91] The predictor 220 may generate a prediction signal based on various prediction methods to be described below. For example, for prediction on one block, the predictor may apply either intra prediction or inter prediction, and, as well, apply both of intra prediction and inter prediction at the same time. The latter may be called combined inter and intra prediction

(CIIP). Further, the predictor may be based on an intra block copy (IBC) prediction mode, or a palette mode in order to perform prediction on a block. The IBC prediction mode or palette mode may be used for content image/video coding of a game or the like, such as screen content coding (SCC). The IBC basically performs prediction in a current picture, but it may be performed similarly to inter prediction in that it derives a reference block in a current picture. That is, the IBC may use at least one of inter prediction techniques described in the present document. The palette mode may be regarded as an example of intra coding or intra prediction. When the palette mode is applied, information on a palette table and a palette index may be included in the video/image information and signaled.

[92] The intra predictor 231 may predict the current block by referring to the samples in the current picture. The referred samples may be located in the neighbor of or apart from the current block according to the prediction mode. In the intra prediction, prediction modes may include a plurality of non-directional modes and a plurality of directional modes. The intra predictor 231 may determine the prediction mode applied to the current block by using the prediction mode applied to the neighboring block.

[93] The inter predictor 232 may derive a predicted block for the current block based on a reference block (reference sample array) specified by a motion vector on a reference picture. At this time, in order to reduce the amount of motion information transmitted in the inter prediction mode, the motion information may be predicted on a block, subblock, or sample basis based on correlation of motion information between the neighboring block and the current block. The motion information may include a motion vector and a reference picture index. The motion information may further include inter prediction direction (L0 prediction, L1 prediction, Bi prediction, etc.) information. In the case of inter prediction, the neighboring block may include a spatial neighboring block existing in the current picture and a temporal neighboring block existing in the reference picture. For example, the inter predictor 232 may configure a motion information candidate list based on neighboring blocks, and derive a motion vector

and/or a reference picture index of the current block based on received candidate selection information. Inter prediction may be performed based on various prediction modes, and the information on prediction may include information indicating a mode of inter prediction for the current block.

[94] The adder 240 adds obtained residual signal to a prediction signal (predicted block, predicted sample array) output from the predictor (inter predictor 232 and/or intra predictor 231), so that a reconstructed signal (reconstructed picture, reconstructed block, reconstructed sample array) may be generated. When there is no residual for a processing target block as in a case where the skip mode is applied, the predicted block may be used as a reconstructed block.

[95] The adder 240 may be called a reconstructor or a reconstructed block generator. The generated reconstructed signal may be used for intra prediction of a next processing target block in the current block, and as described later, may be output through filtering or be used for inter prediction of a next picture.

[96] Meanwhile, in the picture decoding process, luma mapping with chroma scaling (LMCS) may be applied.

[97] The filter 250 may improve subjective/objective video quality by applying the filtering to the reconstructed signal. For example, the filter 250 may generate a modified reconstructed picture by applying various filtering methods to the reconstructed picture, and may transmit the modified reconstructed picture in the memory 260, specifically in the DPB of the memory 260. The various filtering methods may include, for example, deblocking filtering, sample adaptive offset, an adaptive loop filter, a bilateral filter or the like.

[98] The (modified) reconstructed picture which has been stored in the DPB of the memory 260 may be used as a reference picture in the inter predictor 232. The memory 260 may store motion information of a block in the current picture, from which motion information has been derived (or decoded) and/or motion information of blocks in an already reconstructed picture. The stored motion information may be transmitted to the inter predictor 160 to be utilized as

motion information of a neighboring block or motion information of a temporal neighboring block. The memory 260 may store reconstructed samples of reconstructed blocks in the current picture, and transmit them to the intra predictor 231.

[99] In the present document, embodiments described in the filter 160, the inter predictor 121 and the intra predictor 122 of the encoding apparatus 100 may be similarly or correspondingly applied to the filter 250, the inter predictor 232 and the intra predictor 231 of the decoding apparatus 200.

[100] As described above, prediction is performed in order to increase compression efficiency in performing video coding. Through this, a predicted block including prediction samples for a current block, which is a coding target block, may be generated. Here, the predicted block includes prediction samples in a space domain (or pixel domain). The predicted block may be indentially derived in the encoding apparatus and the decoding apparatus, and the encoding apparatus may increase image coding efficiency by signaling to the decoding apparatus not original sample value of an original block itself but information on residual (residual information) between the original block and the predicted block. The decoding apparatus may derive a residual block including residual samples based on the residual information, generate a reconstructed block including reconstructed samples by adding the residual block to the predicted block, and generate a reconstructed picture including reconstructed blocks.

[101] The residual information may be generated through transform and quantization procedures. For example, the encoding apparatus may derive a residual block between the original block and the predicted block, derive transform coefficients by performing a transform procedure on residual samples (residual sample array) included in the residual block, and derive quantized transform coefficients by performing a quantization procedure on the transform coefficients, so that it may signal associated residual information to the decoding apparatus (through a bitstream). Here, the residual information may include value information, position

information, a transform technique, transform kernel, a quantization parameter or the like of the quantized transform coefficients. The decoding apparatus may perform a quantization/dequantization procedure and derive the residual samples (or residual sample block), based on residual information. The decoding apparatus may generate a reconstructed block based on a predicted block and the residual block. The encoding apparatus may derive a residual block by dequantizing/inverse transforming quantized transform coefficients for reference for inter prediction of a next picture, and may generate a reconstructed picture based on this.

[102] FIG. 3 schematically illustrates a multiple transform technique according to an embodiment of the present disclosure.

[103] Referring to FIG. 3, a transformer may correspond to the transformer in the encoding apparatus of foregoing FIG. 1, and an inverse transformer may correspond to the inverse transformer in the encoding apparatus of foregoing FIG. 1, or to the inverse transformer in the decoding apparatus of FIG. 2.

[104] The transformer may derive (primary) transform coefficients by performing a primary transform based on residual samples (residual sample array) in a residual block (S410). This primary transform may be referred to as a core transform. Herein, the primary transform may be based on multiple transform selection (MTS), and when a multiple transform is applied as the primary transform, it may be referred to as a multiple core transform.

[105] The multiple core transform may represent a method of transforming additionally using discrete cosine transform (DCT) type 2 and discrete sine transform (DST) type 7, DCT type 8, and/or DST type 1. That is, the multiple core transform may represent a transform method of transforming a residual signal (or residual block) of a space domain into transform coefficients (or primary transform coefficients) of a frequency domain based on a plurality of transform kernels selected from among the DCT type 2, the DST type 7, the DCT type 8 and

the DST type 1. Herein, the primary transform coefficients may be called temporary transform coefficients from the viewpoint of the transformer.

[106] In other words, when the conventional transform method is applied, transform coefficients might be generated by applying transform from a space domain to a frequency domain for a residual signal (or residual block) based on the DCT type 2. Unlike to this, when the multiple core transform is applied, transform coefficients (or primary transform coefficients) may be generated by applying transform from a space domain to a frequency domain for a residual signal (or residual block) based on the DCT type 2, the DST type 7, the DCT type 8, and/or DST type 1. Herein, the DCT type 2, the DST type 7, the DCT type 8, and the DST type 1 may be called a transform type, transform kernel or transform core. These DCT/DST transform types can be defined based on basis functions.

[107] When the multiple core transform is performed, a vertical transform kernel and a horizontal transform kernel for a target block may be selected from among the transform kernels, a vertical transform may be performed on the target block based on the vertical transform kernel, and a horizontal transform may be performed on the target block based on the horizontal transform kernel. Here, the horizontal transform may indicate a transform on horizontal components of the target block, and the vertical transform may indicate a transform on vertical components of the target block. The vertical transform kernel/horizontal transform kernel may be adaptively determined based on a prediction mode and/or a transform index for the target block (CU or subblock) including a residual block.

[108] Further, according to an example, if the primary transform is performed by applying the MTS, a mapping relationship for transform kernels may be set by setting specific basis functions to predetermined values and combining basis functions to be applied in the vertical transform or the horizontal transform. For example, when the horizontal transform kernel is expressed as $trTypeHor$ and the vertical direction transform kernel is expressed as $trTypeVer$,

a trTypeHor or trTypeVer value of 0 may be set to DCT2, a trTypeHor or trTypeVer value of 1 may be set to DST7, and a trTypeHor or trTypeVer value of 2 may be set to DCT8.

[109] In this case, MTS index information may be encoded and signaled to the decoding apparatus to indicate any one of a plurality of transform kernel sets. For example, an MTS index of 0 may indicate that both trTypeHor and trTypeVer values are 0, an MTS index of 1 may indicate that both trTypeHor and trTypeVer values are 1, an MTS index of 2 may indicate that the trTypeHor value is 2 and the trTypeVer value is 1, an MTS index of 3 may indicate that the trTypeHor value is 1 and the trTypeVer value is 2, and an MTS index of 4 may indicate that both both trTypeHor and trTypeVer values are 2.

[110] In one example, transform kernel sets according to MTS index information are illustrated in the following table.

[111] [Table 1]

| tu_mts_idx[x0][y0] | 0 | 1 | 2 | 3 | 4 |
|-------------------------------|----------|----------|----------|----------|----------|
| trTypeHor | 0 | 1 | 2 | 1 | 2 |
| trTypeVer | 0 | 1 | 1 | 2 | 2 |

[112] The transformer may derive modified (secondary) transform coefficients by performing the secondary transform based on the (primary) transform coefficients (S420). The primary transform is a transform from a spatial domain to a frequency domain, and the secondary transform refers to transforming into a more compressive expression by using a correlation existing between (primary) transform coefficients. The secondary transform may include a non-separable transform. In this case, the secondary transform may be called a non-separable secondary transform (NSST), or a mode-dependent non-separable secondary transform (MDNSST). The non-separable secondary transform may represent a transform

which generates modified transform coefficients (or secondary transform coefficients) for a residual signal by secondary-transforming, based on a non-separable transform matrix, (primary) transform coefficients derived through the primary transform. At this time, the vertical transform and the horizontal transform may not be applied separately (or horizontal and vertical transforms may not be applied independently) to the (primary) transform coefficients, but the transforms may be applied at once based on the non-separable transform matrix. In other words, the non-separable secondary transform may represent a transform method in which is not separately applied in the vertical direction and the horizontal direction for the (primary) transform coefficients, and for example, two-dimensional signals (transform coefficients) are re-arranged to a one-dimensional signal through a certain determined direction (e.g., row-first direction or column-first direction), and then modified transform coefficients (or secondary transform coefficients) are generated based on the non-separable transform matrix. For example, according to a row-first order, $M \times N$ blocks are disposed in a line in an order of a first row, a second row, ..., and an N th row. According to a column-first order, $M \times N$ blocks are disposed in a line in an order of a first column, a second column, ..., and an N th column. The non-separable secondary transform may be applied to a top-left region of a block configured with (primary) transform coefficients (hereinafter, may be referred to as a transform coefficient block). For example, if the width (W) and the height (H) of the transform coefficient block are all equal to or greater than 8, an 8×8 non-separable secondary transform may be applied to a top-left 8×8 region of the transform coefficient block. Further, if the width (W) and the height (H) of the transform coefficient block are all equal to or greater than 4, and the width (W) or the height (H) of the transform coefficient block is less than 8, then a 4×4 non-separable secondary transform may be applied to a top-left $\min(8, W) \times \min(8, H)$ region of the transform coefficient block. However, the embodiment is not limited to this, and for example, even if only the condition that the width (W) or height (H) of the transform coefficient block

is equal to or greater than 4 is satisfied, the 4×4 non-separable secondary transform may be applied to the top-left min(8,W)×min(8,H) region of the transform coefficient block.

[113] Specifically, for example, if a 4x4 input block is used, the non-separable secondary transform may be performed as follows.

[114] The 4x4 input block X may be represented as follows.

[115] [Equation 1]

$$X = \begin{bmatrix} X_{00} & X_{01} & X_{02} & X_{03} \\ X_{10} & X_{11} & X_{12} & X_{13} \\ X_{20} & X_{21} & X_{22} & X_{23} \\ X_{30} & X_{31} & X_{32} & X_{33} \end{bmatrix}$$

[116] If the X is represented in the form of a vector, the vector \vec{X} may be represented as below.

[117] [Equation 2]

$$\vec{X} = [X_{00} \ X_{01} \ X_{02} \ X_{03} \ X_{10} \ X_{11} \ X_{12} \ X_{13} \ X_{20} \ X_{21} \ X_{22} \ X_{23} \ X_{30} \ X_{31} \ X_{32} \ X_{33}]^T$$

[118] In Equation 2, the vector \vec{X} is a one-dimensional vector obtained by rearranging the two-dimensional block X of Equation 1 according to the row-first order.

[119] In this case, the secondary non-separable transform may be calculated as below.

[120] [Equation 3]

$$\vec{F} = T \cdot \vec{X}$$

[121] In this equation, \vec{F} represents a transform coefficient vector, and T represents a 16x16 (non-separable) transform matrix.

[122] Through foregoing Equation 3, a 16x1 transform coefficient vector \vec{F} may be derived, and the \vec{F} may be re-organized into a 4x4 block through a scan order (horizontal, vertical, diagonal and the like). However, the above-described calculation is an example, and hypercube-Givens transform (HyGT) or the like may be used for the calculation of the non-

separable secondary transform in order to reduce the computational complexity of the non-separable secondary transform.

[123] Meanwhile, in the non-separable secondary transform, a transform kernel (or transform core, transform type) may be selected to be mode dependent. In this case, the mode may include the intra prediction mode and/or the inter prediction mode.

[124] As described above, the non-separable secondary transform may be performed based on an 8x8 transform or a 4x4 transform determined based on the width (W) and the height (H) of the transform coefficient block. The 8x8 transform refers to a transform that is applicable to an 8x8 region included in the transform coefficient block when both W and H are equal to or greater than 8, and the 8x8 region may be a top-left 8x8 region in the transform coefficient block. Similarly, the 4x4 transform refers to a transform that is applicable to a 4x4 region included in the transform coefficient block when both W and H are equal to or greater than 4, and the 4x4 region may be a top-left 4x4 region in the transform coefficient block. . For example, an 8x8 transform kernel matrix may be a 64x64/16x64 matrix, and a 4x4 transform kernel matrix may be a 16x16/8x16 matrix.

[125] Here, to select a mode-dependent transform kernel, two non-separable secondary transform kernels per transform set for a non-separable secondary transform may be configured for both the 8 x 8 transform and the 4 x 4 transform, and there may be four transform sets. That is, four transform sets may be configured for the 8 x 8 transform, and four transform sets may be configured for the 4 x 4 transform. In this case, each of the four transform sets for the 8 x 8 transform may include two 8 x 8 transform kernels, and each of the four transform sets for the 4 x 4 transform may include two 4 x 4 transform kernels.

[126] However, as the size of the transform, that is, the size of a region to which the transform is applied, may be, for example, a size other than 8 x 8 or 4 x 4, the number of sets may be n, and the number of transform kernels in each set may be k.

[127] The transform set may be referred to as an NSST set or an LFNST set. A specific set among the transform sets may be selected, for example, based on the intra prediction mode of the current block (CU or subblock). A low-frequency non-separable transform (LFNST) may be an example of a reduced non-separable transform, which will be described later, and represents a non-separable transform for a low frequency component.

[128] For reference, for example, the intra prediction mode may include two non-directional (or non-angular) intra prediction modes and 65 directional (or angular) intra prediction modes. The non-directional intra prediction modes may include a planar intra prediction mode of No. 0 and a DC intra prediction mode of No. 1, and the directional intra prediction modes may include 65 intra prediction modes of Nos. 2 to 66. However, this is an example, and this document may be applied even when the number of intra prediction modes is different. Meanwhile, in some cases, intra prediction mode No. 67 may be further used, and the intra prediction mode No. 67 may represent a linear model (LM) mode.

[129] FIG. 4 exemplarily shows intra directional modes of 65 prediction directions.

[130] Referring to FIG. 4, on the basis of intra prediction mode 34 having a left upward diagonal prediction direction, the intra prediction modes may be divided into intra prediction modes having horizontal directionality and intra prediction modes having vertical directionality. In FIG. 4, H and V denote horizontal directionality and vertical directionality, respectively, and numerals -32 to 32 indicate displacements in $1/32$ units on a sample grid position. These numerals may represent an offset for a mode index value. Intra prediction modes 2 to 33 have the horizontal directionality, and intra prediction modes 34 to 66 have the vertical directionality. Strictly speaking, intra prediction mode 34 may be considered as being neither horizontal nor vertical, but may be classified as belonging to the horizontal directionality in determining a transform set of a secondary transform. This is because input data is transposed to be used for a vertical direction mode symmetrical on the basis of intra prediction mode 34, and an input data alignment method for a horizontal mode is used for intra prediction mode 34. Transposing

input data means that rows and columns of two-dimensional M x N block data are switched into N x M data. Intra prediction mode 18 and intra prediction mode 50 may represent a horizontal intra prediction mode and a vertical intra prediction mode, respectively, and intra prediction mode 2 may be referred to as a right upward diagonal intra prediction mode because intra prediction mode 2 has a left reference pixel and performs prediction in a right upward direction. Likewise, intra prediction mode 34 may be referred to as a right downward diagonal intra prediction mode, and intra prediction mode 66 may be referred to as a left downward diagonal intra prediction mode.

[131] According to an example, the four transform sets according to the intra prediction mode may be mapped, for example, as shown in the following table.

[132] [Table 2]

| lfnstPredModeIntra | lfnstTrSetIdx |
|---|----------------------|
| lfnstPredModeIntra < 0 | 1 |
| 0 <= lfnstPredModeIntra <= 1 | 0 |
| 2 <= lfnstPredModeIntra <= 12 | 1 |
| 13 <= lfnstPredModeIntra <= 23 | 2 |
| 24 <= lfnstPredModeIntra <= 44 | 3 |
| 45 <= lfnstPredModeIntra <= 55 | 2 |
| 56 <= lfnstPredModeIntra <= 80 | 1 |
| 81 <= lfnstPredModeIntra <= 83 | 0 |

[133] As shown in Table 2, any one of the four transform sets, that is, lfnstTrSetIdx, may be mapped to any one of four indexes, that is, 0 to 3, according to the intra prediction mode.

[134] When it is determined that a specific set is used for the non-separable transform, one of k transform kernels in the specific set may be selected through a non-separable secondary transform index. An encoding apparatus may derive a non-separable secondary transform index indicating a specific transform kernel based on a rate-distortion (RD) check and may signal the non-separable secondary transform index to a decoding apparatus. The decoding apparatus may select one of the k transform kernels in the specific set based on the non-separable secondary transform index. For example, lfnst index value 0 may refer to a first non-separable secondary

transform kernel, lfst index value 1 may refer to a second non-separable secondary transform kernel, and lfst index value 2 may refer to a third non-separable secondary transform kernel. Alternatively, lfst index value 0 may indicate that the first non-separable secondary transform is not applied to the target block, and lfst index values 1 to 3 may indicate the three transform kernels.

[135] The transformer may perform the non-separable secondary transform based on the selected transform kernels, and may obtain modified (secondary) transform coefficients. As described above, the modified transform coefficients may be derived as transform coefficients quantized through the quantizer, and may be encoded and signaled to the decoding apparatus and transferred to the dequantizer/inverse transformer in the encoding apparatus.

[136] Meanwhile, as described above, if the secondary transform is omitted, (primary) transform coefficients, which are an output of the primary (separable) transform, may be derived as transform coefficients quantized through the quantizer as described above, and may be encoded and signaled to the decoding apparatus and transferred to the dequantizer/inverse transformer in the encoding apparatus.

[137] The inverse transformer may perform a series of procedures in the inverse order to that in which they have been performed in the above-described transformer. The inverse transformer may receive (dequantized) transformer coefficients, and derive (primary) transform coefficients by performing a secondary (inverse) transform (S450), and may obtain a residual block (residual samples) by performing a primary (inverse) transform on the (primary) transform coefficients (S460). In this connection, the primary transform coefficients may be called modified transform coefficients from the viewpoint of the inverse transformer. As described above, the encoding apparatus and the decoding apparatus may generate the reconstructed block based on the residual block and the predicted block, and may generate the reconstructed picture based on the reconstructed block.

[138] The decoding apparatus may further include a secondary inverse transform application determinator (or an element to determine whether to apply a secondary inverse transform) and a secondary inverse transform determinator (or an element to determine a secondary inverse transform). The secondary inverse transform application determinator may determine whether to apply a secondary inverse transform. For example, the secondary inverse transform may be an NSST, an RST, or an LFNST and the secondary inverse transform application determinator may determine whether to apply the secondary inverse transform based on a secondary transform flag obtained by parsing the bitstream. In another example, the secondary inverse transform application determinator may determine whether to apply the secondary inverse transform based on a transform coefficient of a residual block.

[139] The secondary inverse transform determinator may determine a secondary inverse transform. In this case, the secondary inverse transform determinator may determine the secondary inverse transform applied to the current block based on an LFNST (NSST or RST) transform set specified according to an intra prediction mode. In an embodiment, a secondary transform determination method may be determined depending on a primary transform determination method. Various combinations of primary transforms and secondary transforms may be determined according to the intra prediction mode. Further, in an example, the secondary inverse transform determinator may determine a region to which a secondary inverse transform is applied based on the size of the current block.

[140] Meanwhile, as described above, if the secondary (inverse) transform is omitted, (dequantized) transform coefficients may be received, the primary (separable) inverse transform may be performed, and the residual block (residual samples) may be obtained. As described above, the encoding apparatus and the decoding apparatus may generate the reconstructed block based on the residual block and the predicted block, and may generate the reconstructed picture based on the reconstructed block.

[141] Meanwhile, in the present disclosure, a reduced secondary transform (RST) in which the size of a transform matrix (kernel) is reduced may be applied in the concept of NSST in order to reduce the amount of computation and memory required for the non-separable secondary transform.

[142] Meanwhile, the transform kernel, the transform matrix, and the coefficient constituting the transform kernel matrix, that is, the kernel coefficient or the matrix coefficient, described in the present disclosure may be expressed in 8 bits. This may be a condition for implementation in the decoding apparatus and the encoding apparatus, and may reduce the amount of memory required to store the transform kernel with a performance degradation that can be reasonably accommodated compared to the existing 9 bits or 10 bits. In addition, the expressing of the kernel matrix in 8 bits may allow a small multiplier to be used, and may be more suitable for single instruction multiple data (SIMD) instructions used for optimal software implementation.

[143] In the present specification, the term "RST" may mean a transform which is performed on residual samples for a target block based on a transform matrix whose size is reduced according to a reduced factor. In the case of performing the reduced transform, the amount of computation required for transform may be reduced due to a reduction in the size of the transform matrix. That is, the RST may be used to address the computational complexity issue occurring at the non-separable transform or the transform of a block of a great size.

[144] RST may be referred to as various terms, such as reduced transform, reduced secondary transform, reduction transform, simplified transform, simple transform, and the like, and the name which RST may be referred to as is not limited to the listed examples. Alternatively, since the RST is mainly performed in a low frequency region including a non-zero coefficient in a transform block, it may be referred to as a Low-Frequency Non-Separable Transform (LFNST). The transform index may be referred to as an LFNST index.

[145] Meanwhile, when the secondary inverse transform is performed based on RST, the inverse transformer 135 of the encoding apparatus 100 and the inverse transformer 222 of the decoding apparatus 200 may include an inverse reduced secondary transformer which derives modified transform coefficients based on the inverse RST of the transform coefficients, and an inverse primary transformer which derives residual samples for the target block based on the inverse primary transform of the modified transform coefficients. The inverse primary transform refers to the inverse transform of the primary transform applied to the residual. In the present disclosure, deriving a transform coefficient based on a transform may refer to deriving a transform coefficient by applying the transform.

[146] FIG. 5 is a diagram illustrating an RST according to an embodiment of the present disclosure.

[147] In the present disclosure, a "target block" may refer to a current block to be coded, a residual block, or a transform block.

[148] In the RST according to an example, an N-dimensional vector may be mapped to an R-dimensional vector located in another space, so that the reduced transform matrix may be determined, where R is less than N. N may mean the square of the length of a side of a block to which the transform is applied, or the total number of transform coefficients corresponding to a block to which the transform is applied, and the reduced factor may mean an R/N value. The reduced factor may be referred to as a reduced factor, reduction factor, simplified factor, simple factor or other various terms. Meanwhile, R may be referred to as a reduced coefficient, but according to circumstances, the reduced factor may mean R. Further, according to circumstances, the reduced factor may mean the N/R value.

[149] In an example, the reduced factor or the reduced coefficient may be signaled through a bitstream, but the example is not limited to this. For example, a predefined value for the reduced factor or the reduced coefficient may be stored in each of the encoding apparatus 100

and the decoding apparatus 200, and in this case, the reduced factor or the reduced coefficient may not be signaled separately.

[150] The size of the reduced transform matrix according to an example may be $R \times N$ less than $N \times N$, the size of a conventional transform matrix, and may be defined as in Equation 4 below.

[151] [Equation 4]

$$T_{R \times N} = \begin{bmatrix} t_{11} & t_{12} & t_{13} & \dots & t_{1N} \\ t_{21} & t_{22} & t_{23} & \dots & t_{2N} \\ \vdots & \vdots & \vdots & \ddots & \vdots \\ t_{R1} & t_{R2} & t_{R3} & \dots & t_{RN} \end{bmatrix}$$

[152] The matrix T in the Reduced Transform block shown in FIG. 5(a) may mean the matrix $T_{R \times N}$ of Equation 4. As shown in FIG. 5(a), when the reduced transform matrix $T_{R \times N}$ is multiplied to residual samples for the target block, transform coefficients for the target block may be derived.

[153] In an example, if the size of the block to which the transform is applied is 8×8 and $R = 16$ (i.e., $R/N = 16/64 = 1/4$), then the RST according to FIG. 5(a) may be expressed as a matrix operation as shown in Equation 5 below. In this case, memory and multiplication calculation can be reduced to approximately $1/4$ by the reduced factor.

[154] In the present disclosure, a matrix operation may be understood as an operation of multiplying a column vector by a matrix, disposed on the left of the column vector, to obtain a column vector.

[155] [Equation 5]

$$\begin{bmatrix} t_{1,1} & t_{1,2} & t_{1,3} & \dots & t_{1,64} \\ t_{2,1} & t_{2,2} & t_{2,3} & \dots & t_{2,64} \\ \vdots & \vdots & \vdots & \ddots & \vdots \\ t_{16,1} & t_{16,2} & t_{16,3} & \dots & t_{16,64} \end{bmatrix} \times \begin{bmatrix} r_1 \\ r_2 \\ \vdots \\ r_{64} \end{bmatrix}$$

[156] In Equation 5, r_1 to r_{64} may represent residual samples for the target block and may be specifically transform coefficients generated by applying a primary transform. As a result of the calculation of Equation 5 transform coefficients c_i for the target block may be derived, and a process of deriving c_i may be as in Equation 6.

[157] [Equation 6]

```

for i from 1 to R:
     $c_i = 0$ 
    for j from 1 to N
         $c_i += t_{ij} * r_j$ 

```

[158] As a result of the calculation of Equation 6, transform coefficients c_1 to c_R for the target block may be derived. That is, when $R=16$, transform coefficients c_1 to c_{16} for the target block may be derived. If, instead of RST, a regular transform is applied and a transform matrix of 64×64 ($N \times N$) size is multiplied to residual samples of 64×1 ($N \times 1$) size, then only 16 (R) transform coefficients are derived for the target block because RST was applied, although 64 (N) transform coefficients are derived for the target block. Since the total number of transform coefficients for the target block is reduced from N to R , the amount of data transmitted by the encoding apparatus 100 to the decoding apparatus 200 decreases, so efficiency of transmission between the encoding apparatus 100 and the decoding apparatus 200 can be improved.

[159] When considered from the viewpoint of the size of the transform matrix, the size of the regular transform matrix is 64×64 ($N \times N$), but the size of the reduced transform matrix is reduced to 16×64 ($R \times N$), so memory usage in a case of performing the RST can be reduced by an R/N ratio when compared with a case of performing the regular transform. In addition, when compared to the number of multiplication calculations $N \times N$ in a case of using the regular transform matrix, the use of the reduced transform matrix can reduce the number of multiplication calculations by the R/N ratio ($R \times N$).

[160] In an example, the transformer 132 of the encoding apparatus 100 may derive transform coefficients for the target block by performing the primary transform and the RST-based secondary transform on residual samples for the target block. These transform coefficients may be transferred to the inverse transformer of the decoding apparatus 200, and the inverse transformer 222 of the decoding apparatus 200 may derive the modified transform coefficients based on the inverse reduced secondary transform (RST) for the transform coefficients, and may derive residual samples for the target block based on the inverse primary transform for the modified transform coefficients.

[161] The size of the inverse RST matrix $T_{N \times R}$ according to an example is $N \times R$ less than the size $N \times N$ of the regular inverse transform matrix, and is in a transpose relationship with the reduced transform matrix $T_{R \times N}$ shown in Equation 4.

[162] The matrix T^t in the Reduced Inv. Transform block shown in FIG. 5(b) may mean the inverse RST matrix $T_{R \times N}^T$ (the superscript T means transpose). When the inverse RST matrix $T_{R \times N}^T$ is multiplied to the transform coefficients for the target block as shown in FIG. 5(b), the modified transform coefficients for the target block or the residual samples for the current block may be derived. The inverse RST matrix $T_{R \times N}^T$ may be expressed as $(T_{R \times N})_{N \times R}^T$.

[163] More specifically, when the inverse RST is applied as the secondary inverse transform, the modified transform coefficients for the target block may be derived when the inverse RST matrix $T_{R \times N}^T$ is multiplied to the transform coefficients for the target block. Meanwhile, the inverse RST may be applied as the inverse primary transform, and in this case, the residual samples for the target block may be derived when the inverse RST matrix $T_{R \times N}^T$ is multiplied to the transform coefficients for the target block.

[164] In an example, if the size of the block to which the inverse transform is applied is 8×8 and $R = 16$ (i.e., $R/N = 16/64 = 1/4$), then the RST according to FIG. 5(b) may be expressed as a matrix operation as shown in Equation 7 below.

[165] [Equation 7]

$$\begin{bmatrix} t_{1,1} & t_{2,1} & & t_{16,1} \\ t_{1,2} & t_{2,2} & \dots & t_{16,2} \\ t_{1,3} & t_{2,3} & & t_{16,3} \\ \vdots & \vdots & & \vdots \\ & \vdots & \ddots & \vdots \\ t_{1,64} & t_{2,64} & \dots & t_{16,64} \end{bmatrix} \times \begin{bmatrix} c_1 \\ c_2 \\ \vdots \\ c_{16} \end{bmatrix}$$

[166] In Equation 7, c_1 to c_{16} may represent the transform coefficients for the target block. As a result of the calculation of Equation 7, r_i representing the modified transform coefficients for the target block or the residual samples for the target block may be derived, and the process of deriving r_i may be as in Equation 8.

[167] [Equation 8]

| |
|---|
| <p>For i from 1 to N $r_i = 0$ for j from 1 to R $r_i += t_{ji} * c_j$</p> |
|---|

[168] As a result of the calculation of Equation 8, r_1 to r_N representing the modified transform coefficients for the target block or the residual samples for the target block may be derived. When considered from the viewpoint of the size of the inverse transform matrix, the size of the regular inverse transform matrix is 64×64 ($N \times N$), but the size of the reduced inverse transform matrix is reduced to 64×16 ($R \times N$), so memory usage in a case of performing the inverse RST can be reduced by an R/N ratio when compared with a case of performing the regular inverse transform. In addition, when compared to the number of multiplication calculations $N \times N$ in a case of using the regular inverse transform matrix, the use of the reduced inverse transform matrix can reduce the number of multiplication calculations by the R/N ratio ($N \times R$).

[169] A transform set configuration shown in Table 2 may also be applied to an 8×8 RST. That is, the 8×8 RST may be applied according to a transform set in Table 2. Since one transform set includes two or three transforms (kernels) according to an intra prediction mode,

it may be configured to select one of up to four transforms including that in a case where no secondary transform is applied. In a transform where no secondary transform is applied, it may be considered to apply an identity matrix. Assuming that indexes 0, 1, 2, and 3 are respectively assigned to the four transforms (e.g., index 0 may be allocated to a case where an identity matrix is applied, that is, a case where no secondary transform is applied), a transform index or an lfnst index as a syntax element may be signaled for each transform coefficient block, thereby designating a transform to be applied. That is, for a top-left 8 x 8 block, through the transform index, it is possible to designate an 8 x 8 RST in an RST configuration, or to designate an 8 x 8 lfnst when the LFNST is applied. The 8 x 8 lfnst and the 8 x 8 RST refer to transforms applicable to an 8 x 8 region included in the transform coefficient block when both W and H of the target block to be transformed are equal to or greater than 8, and the 8 x 8 region may be a top-left 8 x 8 region in the transform coefficient block. Similarly, a 4 x 4 lfnst and a 4 x 4 RST refer to transforms applicable to a 4 x 4 region included in the transform coefficient block when both W and H of the target block to are equal to or greater than 4, and the 4 x 4 region may be a top-left 4 x 4 region in the transform coefficient block.

[170] According to an embodiment of the present disclosure, for a transform in an encoding process, only 48 pieces of data may be selected and a maximum 16 x 48 transform kernel matrix may be applied thereto, rather than applying a 16 x 64 transform kernel matrix to 64 pieces of data forming an 8 x 8 region. Here, "maximum" means that m has a maximum value of 16 in an m x 48 transform kernel matrix for generating m coefficients. That is, when an RST is performed by applying an m x 48 transform kernel matrix ($m \leq 16$) to an 8 x 8 region, 48 pieces of data are input and m coefficients are generated. When m is 16, 48 pieces of data are input and 16 coefficients are generated. That is, assuming that 48 pieces of data form a 48×1 vector, a 16×48 matrix and a 48×1 vector are sequentially multiplied, thereby generating a 16×1 vector. Here, the 48 pieces of data forming the 8 x 8 region may be properly arranged, thereby forming the 48 x 1 vector. For example, a 48 x 1 vector may be constructed based on 48 pieces of data

constituting a region excluding the bottom right 4 x 4 region among the 8 x 8 regions. Here, when a matrix operation is performed by applying a maximum 16 x 48 transform kernel matrix, 16 modified transform coefficients are generated, and the 16 modified transform coefficients may be arranged in a top-left 4 x 4 region according to a scanning order, and a top-right 4 x 4 region and a bottom-left 4 x 4 region may be filled with zeros.

[171] For an inverse transform in a decoding process, the transposed matrix of the foregoing transform kernel matrix may be used. That is, when an inverse RST or LFNST is performed in the inverse transform process performed by the decoding apparatus, input coefficient data to which the inverse RST is applied is configured in a one-dimensional vector according to a predetermined arrangement order, and a modified coefficient vector obtained by multiplying the one-dimensional vector and a corresponding inverse RST matrix on the left of the one-dimensional vector may be arranged in a two-dimensional block according to a predetermined arrangement order.

[172] In summary, in the transform process, when an RST or LFNST is applied to an 8 x 8 region, a matrix operation of 48 transform coefficients in top-left, top-right, and bottom-left regions of the 8 x 8 region excluding the bottom-right region among transform coefficients in the 8 x 8 region and a 16 x 48 transform kernel matrix. For the matrix operation, the 48 transform coefficients are input in a one-dimensional array. When the matrix operation is performed, 16 modified transform coefficients are derived, and the modified transform coefficients may be arranged in the top-left region of the 8 x 8 region.

[173] On the contrary, in the inverse transform process, when an inverse RST or LFNST is applied to an 8 x 8 region, 16 transform coefficients corresponding to a top-left region of the 8 x 8 region among transform coefficients in the 8 x 8 region may be input in a one-dimensional array according to a scanning order and may be subjected to a matrix operation with a 48 x 16 transform kernel matrix. That is, the matrix operation may be expressed as $(48 \times 16 \text{ matrix}) * (16 \times 1 \text{ transform coefficient vector}) = (48 \times 1 \text{ modified transform coefficient vector})$. Here, an

$n \times 1$ vector may be interpreted to have the same meaning as an $n \times 1$ matrix and may thus be expressed as an $n \times 1$ column vector. Further, * denotes matrix multiplication. When the matrix operation is performed, 48 modified transform coefficients may be derived, and the 48 modified transform coefficients may be arranged in top-left, top-right, and bottom-left regions of the 8×8 region excluding a bottom-right region.

[174] When a secondary inverse transform is based on an RST, the inverse transformer 135 of the encoding apparatus 100 and the inverse transformer 222 of the decoding apparatus 200 may include an inverse reduced secondary transformer to derive modified transform coefficients based on an inverse RST on transform coefficients and an inverse primary transformer to derive residual samples for the target block based on an inverse primary transform on the modified transform coefficients. The inverse primary transform refers to the inverse transform of a primary transform applied to a residual. In the present disclosure, deriving a transform coefficient based on a transform may refer to deriving the transform coefficient by applying the transform.

[175] The above-described non-separated transform, the LFNST, will be described in detail as follows. The LFNST may include a forward transform by the encoding apparatus and an inverse transform by the decoding apparatus.

[176] The encoding apparatus receives a result (or a part of a result) derived after applying a primary (core) transform as an input, and applies a forward secondary transform (secondary transform).

[177] [Equation 9]

$$y = G^T x$$

[178] In Equation 9, x and y are inputs and outputs of the secondary transform, respectively, and G is a matrix representing the secondary transform, and transform basis vectors are composed of column vectors. In the case of an inverse LFNST, when the dimension of the

transformation matrix G is expressed as [number of rows x number of columns], in the case of an forward LFNST, the transposition of matrix G becomes the dimension of G^T .

[179] For the inverse LFNST, the dimensions of matrix G are [48 x 16], [48 x 8], [16 x 16], [16 x 8], and the [48 x 8] matrix and the [16 x 8] matrix are partial matrices that sampled 8 transform basis vectors from the left of the [48 x 16] matrix and the [16 x 16] matrix, respectively.

[180] On the other hand, for the forward LFNST, the dimensions of matrix G^T are [16 x 48], [8 x 48], [16 x 16], [8 x 16], and the [8 x 48] matrix and the [8 x 16] matrix are partial matrices obtained by sampling 8 transform basis vectors from the top of the [16 x 48] matrix and the [16 x 16] matrix, respectively.

[181] Therefore, in the case of the forward LFNST, a [48 x 1] vector or [16 x 1] vector is possible as an input x , and a [16 x 1] vector or a [8 x 1] vector is possible as an output y . In video coding and decoding, the output of the forward primary transform is two-dimensional (2D) data, so to construct the [48 x 1] vector or the [16 x 1] vector as the input x , a one-dimensional vector must be constructed by properly arranging the 2D data that is the output of the forward transformation.

[182] FIG. 6 is a diagram illustrating a sequence of arranging output data of a forward primary transformation into a one-dimensional vector according to an example. The left diagrams of (a) and (b) of FIG. 6 show the sequence for constructing a [48 x 1] vector, and the right diagrams of (a) and (b) of FIG. 6 shows the sequence for constructing a [16 x 1] vector. In the case of the LFNST, a one-dimensional vector x can be obtained by sequentially arranging 2D data in the same order as in (a) and (b) of FIG. 6.

[183] The arrangement direction of the output data of the forward primary transform may be determined according to an intra prediction mode of the current block. For example, when the intra prediction mode of the current block is in the horizontal direction with respect to the diagonal direction, the output data of the forward primary transform may be arranged in the

order of (a) of FIG. 6, and when the intra prediction mode of the current block is in the vertical direction with respect to the diagonal direction, the output data of the forward primary transform may be arranged in the order of (b) of FIG. 6.

[184] According to an example, an arrangement order different from the arrangement orders of (a) and (b) FIG. 6 may be applied, and in order to derive the same result (y vector) as when the arrangement orders of (a) and (b) FIG. 6 is applied, the column vectors of the matrix G may be rearranged according to the arrangement order. That is, it is possible to rearrange the column vectors of G so that each element constituting the x vector is always multiplied by the same transform basis vector.

[185] Since the output y derived through Equation 9 is a one-dimensional vector, when two-dimensional data is required as input data in the process of using the result of the forward secondary transformation as an input, for example, in the process of performing quantization or residual coding, the output y vector of Equation 9 must be properly arranged as 2D data again.

[186] FIG. 7 is a diagram illustrating a sequence of arranging output data of a forward secondary transform into a two-dimensional block according to an example.

[187] In the case of the LFNST, output values may be arranged in a 2D block according to a predetermined scan order. (a) of FIG. 7 shows that when the output y is a [16 x 1] vector, the output values are arranged at 16 positions of the 2D block according to a diagonal scan order. (b) of FIG. 7 shows that when the output y is a [8 x 1] vector, the output values are arranged at 8 positions of the 2D block according to the diagonal scan order, and the remaining 8 positions are filled with zeros. X in (b) of FIG. 7 indicates that it is filled with zero.

[188] According to another example, since the order in which the output vector y is processed in performing quantization or residual coding may be preset, the output vector y may not be arranged in the 2D block as shown in FIG. 7. However, in the case of the residual coding, data coding may be performed in 2D block (eg, 4x4) units such as CG (Coefficient Group), and in

this case, the data are arranged according to a specific order as in the diagonal scan order of FIG. 7.

[189] Meanwhile, the decoding apparatus may configure the one-dimensional input vector y by arranging two-dimensional data output through a dequantization process or the like according to a preset scan order for the inverse transformation. The input vector y may be output as the output vector x by the following equation.

[190] [Equation 10]

$$x = Gy$$

[191] In the case of the inverse LFNST, an output vector x can be derived by multiplying an input vector y , which is a $[16 \times 1]$ vector or a $[8 \times 1]$ vector, by a G matrix. For the inverse LFNST, the output vector x can be either a $[48 \times 1]$ vector or a $[16 \times 1]$ vector.

[192] The output vector x is arranged in a two-dimensional block according to the order shown in FIG. 6 and is arranged as two-dimensional data, and this two-dimensional data becomes input data (or a part of input data) of the inverse primary transformation.

[193] Accordingly, the inverse secondary transformation is the opposite of the forward secondary transformation process as a whole, and in the case of the inverse transformation, unlike in the forward direction, the inverse secondary transformation is first applied, and then the inverse primary transformation is applied.

[194] In the inverse LFNST, one of 8 $[48 \times 16]$ matrices and 8 $[16 \times 16]$ matrices may be selected as the transformation matrix G . Whether to apply the $[48 \times 16]$ matrix or the $[16 \times 16]$ matrix depends on the size and shape of the block.

[195] In addition, 8 matrices may be derived from four transform sets as shown in Table 2 above, and each transform set may consist of two matrices. Which transform set to use among the 4 transform sets is determined according to the intra prediction mode, and more specifically, the transform set is determined based on the value of the intra prediction mode extended by considering the Wide Angle Intra Prediction (WAIP). Which matrix to select from among the

two matrices constituting the selected transform set is derived through index signaling. More specifically, 0, 1, and 2 are possible as the transmitted index value, 0 may indicate that the LFNST is not applied, and 1 and 2 may indicate any one of two transform matrices constituting a transform set selected based on the intra prediction mode value.

[196] Meanwhile, as described above, which transform matrix of the $[48 \times 16]$ matrix and the $[16 \times 16]$ matrix is applied to the LFNST is determined by the size and shape of the transform target block.

[197] FIG. 8 is a diagram illustrating a block shape to which the LFNST is applied. (a) of FIG. 8 shows 4×4 blocks, (b) shows 4×8 and 8×4 blocks, (c) shows $4 \times N$ or $N \times 4$ blocks in which N is 16 or more, (d) shows 8×8 blocks, (e) shows $M \times N$ blocks where $M \geq 8$, $N \geq 8$, and $N > 8$ or $M > 8$.

[198] In FIG. 8, blocks with thick borders indicate regions to which the LFNST is applied. For the blocks of FIGs. 10 (a) and (b), the LFNST is applied to the top-left 4×4 region, and for the block of FIG. 8 (c), the LFNST is applied individually the two top-left 4×4 regions are continuously arranged. In (a), (b), and (c) of FIG. 8, since the LFNST is applied in units of 4×4 regions, this LFNST will be hereinafter referred to as “ 4×4 LFNST”. Based on the matrix dimension for G , a $[16 \times 16]$ or $[16 \times 8]$ matrix may be applied.

[199] More specifically, the $[16 \times 8]$ matrix is applied to the 4×4 block (4×4 TU or 4×4 CU) of FIG. 8 (a) and the $[16 \times 16]$ matrix is applied to the blocks in (b) and (c) of FIG. 8. This is to adjust the computational complexity for the worst case to 8 multiplications per sample.

[200] With respect to (d) and (e) of FIG. 8, the LFNST is applied to the top-left 8×8 region, and this LFNST is hereinafter referred to as “ 8×8 LFNST”. As a corresponding transformation matrix, a $[48 \times 16]$ matrix or $[48 \times 8]$ matrix may be applied. In the case of the forward LFNST, since the $[48 \times 1]$ vector (x vector in Equation 9) is input as input data, all sample values of the top-left 8×8 region are not used as input values of the forward LFNST. That is, as can be seen in the left order of FIG. 6 (a) or the left order of FIG. 6 (b), the $[48 \times 1]$ vector

may be constructed based on samples belonging to the remaining 3 4x4 blocks while leaving the bottom-right 4x4 block as it is.

[201] The $[48 \times 8]$ matrix may be applied to an 8×8 block (8×8 TU or 8×8 CU) in FIG. 8 (d), and the $[48 \times 16]$ matrix may be applied to the 8×8 block in FIG. 8(e). This is also to adjust the computational complexity for the worst case to 8 multiplications per sample.

[202] Depending on the block shape, when the corresponding forward LFNST (4x4 LFNST or 8x8 LFNST) is applied, 8 or 16 output data (y vector in Equation 9, $[8 \times 1]$ or $[16 \times 1]$ vector) is generated. In the forward LFNST, the number of output data is equal to or less than the number of input data due to the characteristics of the matrix G^T .

[203] FIG. 9 is a diagram illustrating an arrangement of output data of a forward LFNST according to an example, and shows a block in which output data of the forward LFNST is arranged according to a block shape.

[204] The shaded area at the top-left of the block shown in FIG. 9 corresponds to the area where the output data of the forward LFNST is located, the positions marked with 0 indicate samples filled with 0 values, and the remaining area represents regions that are not changed by the forward LFNST. In the area not changed by the LFNST, the output data of the forward primary transform remains unchanged.

[205] As described above, since the dimension of the transform matrix applied varies according to the shape of the block, the number of output data also varies. As FIG. 9, the output data of the forward LFNST may not completely fill the top-left 4x4 block. In the case of (a) and (d) of FIG. 9, a $[16 \times 8]$ matrix and a $[48 \times 8]$ matrix are applied to the block indicated by a thick line or a partial region inside the block, respectively, and a $[8 \times 1]$ vector as the output of the forward LFNST is generated. That is, according to the scan order shown in (b) of FIG. 7, only 8 output data may be filled as shown in (a) and (d) of FIG. 9, and 0 may be filled in the remaining 8 positions. In the case of the LFNST applied block of FIG. 8 (d), as shown

in FIG. 9(d), two 4x4 blocks in the top-right and bottom-left adjacent to the top-left 4x4 block are also filled with 0 values.

[206] As described above, basically, by signaling the LFNST index, whether to apply the LFNST and the transform matrix to be applied are specified. As shown FIG. 9, when the LFNST is applied, since the number of output data of the forward LFNST may be equal to or less than the number of input data, a region filled with a zero value occurs as follows.

[207] 1) As shown in (a) of FIG. 9, samples from the 8th and later positions in the scan order in the top-left 4x4 block, that is, samples from the 9th to the 16th.

[208] 2) As shown in (d) and (e) of FIG. 9, when the [48 x 16] matrix or the [48 x 8] matrix is applied, two 4x4 blocks adjacent to the top-left 4x4 block or the second and third 4x4 blocks in the scan order.

[209] Therefore, if non-zero data exists by checking the areas 1) and 2), it is certain that the LFNST is not applied, so that the signaling of the corresponding LFNST index can be omitted.

[210] According to an example, for example, in the case of LFNST adopted in the VVC standard, since signaling of the LFNST index is performed after the residual coding, the encoding apparatus may know whether there is the non-zero data (significant coefficients) for all positions within the TU or CU block through the residual coding. Accordingly, the encoding apparatus may determine whether to perform signaling on the LFNST index based on the existence of the non-zero data, and the decoding apparatus may determine whether the LFNST index is parsed. When the non-zero data does not exist in the area designated in 1) and 2) above, signaling of the LFNST index is performed.

[211] Since a truncated unary code is applied as a binarization method for the LFNST index, the LFNST index consists of up to two bins, and 0, 10, and 11 are assigned as binary codes for possible LFNST index values of 0, 1, and 2, respectively. In the case of the LFNST currently adopted for VVC, a context-based CABAC coding is applied to the first bin (regular coding), and a bypass coding is applied to the second bin. The total number of contexts for the first bin

is 2, when (DCT-2, DCT-2) is applied as a primary transform pair for the horizontal and vertical directions, and a luma component and a chroma component are coded in a dual tree type, one context is allocated and another context applies for the remaining cases. The coding of the LFNST index is shown in a table as follows.

[212] [Table 3]

| Syntax element | binIdx | | | | | |
|-----------------|--|--------|----|----|----|------|
| | 0 | 1 | 2 | 3 | 4 | >= 5 |
| lfnst_idx[][] | (tu_mts_idx[x0][y0] == 0 && treeType != SINGLE_TREE) ? 1 : 0 | bypass | na | na | na | na |

[213] Meanwhile, for the adopted LFNST, the following simplification methods may be applied.

[214] (i) According to an example, the number of output data for the forward LFNST may be limited to a maximum of 16.

[215] In the case of (c) of FIG. 8, the 4x4 LFNST may be applied to two 4x4 regions adjacent to the top-left, respectively, and in this case, a maximum of 32 LFNST output data may be generated. when the number of output data for forward LFNST is limited to a maximum of 16, in the case of 4xN/Nx4 (N≥16) blocks (TU or CU), the 4x4 LFNST is only applied to one 4x4 region in the top-left, the LFNST may be applied only once to all blocks of FIG. 8. Through this, the implementation of image coding may be simplified.

[216] FIG. 10 shows that the number of output data for the forward LFNST is limited to a maximum of 16 according to an example. As FIG. 10, when the LFNST is applied to the most top-left 4x4 region in a 4xN or Nx4 block in which N is 16 or more, the output data of the forward LFNST becomes 16 pieces.

[217] (ii) According to an example, zero-out may be additionally applied to a region to which the LFNST is not applied. In this document, the zero-out may mean filling values of all positions belonging to a specific region with a value of 0. That is, the zero-out can be applied

to a region that is not changed due to the LFNST and maintains the result of the forward primary transformation. As described above, since the LFNST is divided into the 4x4 LFNST and the 8x8 LFNST, the zero-out can be divided into two types ((ii)-(A) and (ii)-(B)) as follows.

[218] (ii)-(A) When the 4x4 LFNST is applied, a region to which the 4x4 LFNST is not applied may be zeroed out. FIG. 11 is a diagram illustrating the zero-out in a block to which the 4x4 LFNST is applied according to an example.

[219] As shown in FIG. 11, with respect to a block to which the 4x4 LFNST is applied, that is, for all of the blocks in (a), (b) and (c) of FIG. 9, the whole region to which the LFNST is not applied may be filled with zeros.

[220] On the other hand, (d) of FIG. 11 shows that when the maximum value of the number of the output data of the forward LFNST is limited to 16 as shown in FIG. 10, the zero-out is performed on the remaining blocks to which the 4x4 LFNST is not applied.

[221] (ii)-(B) When the 8x8 LFNST is applied, a region to which the 8x8 LFNST is not applied may be zeroed out. FIG. 12 is a diagram illustrating the zero-out in a block to which the 8x8 LFNST is applied according to an example.

[222] As shown in FIG. 12, with respect to a block to which the 8x8 LFNST is applied, that is, for all of the blocks in (d) and (e) of FIG. 9, the whole region to which the LFNST is not applied may be filled with zeros.

[223] (iii) Due to the zero-out presented in (ii) above, the area filled with zeros may be not same when the LFNST is applied. Accordingly, it is possible to check whether the non-zero data exists according to the zero-out proposed in (ii) over a wider area than the case of the LFNST of FIG. 9.

[224] For example, when (ii)-(B) is applied, after checking whether the non-zero data exists where the area filled with zero values in (d) and (e) of FIG. 9 in addition to the area filled with 0 additionally in FIG. 12, signaling for the LFNST index can be performed only when the non-zero data does not exist.

[225] Of course, even if the zero-out proposed in (ii) is applied, it is possible to check whether the non-zero data exists in the same way as the existing LFNST index signaling. That is, after checking whether the non-zero data exists in the block filled with zeros in FIG. 9, the LFNST index signaling may be applied. In this case, the encoding apparatus only performs the zero out and the decoding apparatus does not assume the zero out, that is, checking only whether the non-zero data exists only in the area explicitly marked as 0 in FIG. 9, may perform the LFNST index parsing.

[226] Alternatively, according to another example, the zero-out may be performed as shown in FIG. 13. FIG. 13 is a diagram illustrating the zero-out in a block to which the 8x8 LFNST is applied according to another example.

[227] As shown in FIGs. 11 and 12, the zero-out may be applied to all regions other than the region to which the LFNST is applied, or the zero-out may be applied only to a partial region as shown in FIG. 13. The zero-out is applied only to regions other than the top-left 8x8 region of FIG. 13, the zero-out may not be applied to the bottom-right 4x4 block within the top-left 8x8 region.

[228] Various embodiments in which combinations of the simplification methods ((i), (ii)-(A), (ii)-(B), (iii)) for the LFNST are applied may be derived. Of course, the combinations of the above simplification methods are not limited to the following embodiment, and any combination may be applied to the LFNST.

[229] Embodiment

[230] - Limit the number of output data for forward LFNST to a maximum of 16 → (i)

[231] - When the 4x4 LFNST is applied, all areas to which the 4x4 LFNST is not applied are zero-out → (ii)-(A)

[232] - When the 8x8 LFNST is applied, all areas to which the 8x8 LFNST is not applied are zero-out → (ii)-(B)

[233] - After checking whether the non-zero data exists also the existing area filled with zero value and the area filled with zeros due to additional zero outs ((ii)-(A), (ii)-(B)), the LFNST index is signaled only when the non-zero data does not exist → (iii)

[234] In the case of Embodiment, when the LFNST is applied, an area in which the non-zero output data can exist is limited to the inside of the top-left 4x4 area. In more detail, in the case of FIG. 11 (a) and FIG. 12 (a), the 8th position in the scan order is the last position where non-zero data can exist. In the case of FIG. 11 (b) and (c) and FIG. 12 (b), the 16th position in the scan order (ie, the position of the bottom-right edge of the top-left 4x4 block) is the last position where data other than 0 may exist.

[235] Therefore, when the LFNST is applied, after checking whether the non-zero data exists in a position where the residual coding process is not allowed (at a position beyond the last position), it can be determined whether the LFNST index is signaled.

[236] In the case of the zero-out method proposed in (ii), since the number of data finally generated when both the primary transform and the LFNST are applied, the amount of computation required to perform the entire transformation process can be reduced. That is, when the LFNST is applied, since zero-out is applied to the forward primary transform output data existing in a region to which the LFNST is not applied, there is no need to generate data for the region that become zero-out during performing the forward primary transform. Accordingly, it is possible to reduce the amount of computation required to generate the corresponding data. The additional effects of the zero-out method proposed in (ii) are summarized as follows.

[237] First, as described above, the amount of computation required to perform the entire transform process is reduced.

[238] In particular, when (ii)-(B) is applied, the amount of calculation for the worst case is reduced, so that the transform process can be lightened. In other words, in general, a large amount of computation is required to perform a large-size primary transformation. By applying

(ii)-(B), the number of data derived as a result of performing the forward LFNST can be reduced to 16 or less. In addition, as the size of the entire block (TU or CU) increases, the effect of reducing the amount of transform operation is further increased.

[239] Second, the amount of computation required for the entire transform process can be reduced, thereby reducing the power consumption required to perform the transform.

[240] Third, the latency involved in the transform process is reduced.

[241] The secondary transformation such as the LFNST adds a computational amount to the existing primary transformation, thus increasing the overall delay time involved in performing the transformation. In particular, in the case of intra prediction, since reconstructed data of neighboring blocks is used in the prediction process, during encoding, an increase in latency due to a secondary transformation leads to an increase in latency until reconstruction. This can lead to an increase in overall latency of intra prediction encoding.

[242] However, if the zero-out suggested in (ii) is applied, the delay time of performing the primary transform can be greatly reduced when LFNST is applied, the delay time for the entire transform is maintained or reduced, so that the encoding apparatus can be implemented more simply.

[243] Meanwhile, in the conventional intra prediction, a coding target block is regarded as one coding unit, and coding is performed without partition thereof. However, the ISP (Intra Sub-Partitions) coding refers to performing the intra prediction coding with the coding target block being partitioned in a horizontal direction or a vertical direction. In this case, a reconstructed block may be generated by performing encoding/decoding in units of partitioned blocks, and the reconstructed block may be used as a reference block of the next partitioned block. According to an example, in the ISP coding, one coding block may be partitioned into two or four sub-blocks and be coded, and in the ISP, intra prediction is performed on one sub-block by referring to the reconstructed pixel value of a sub-block located adjacent to the left or

top side thereof. Hereinafter, the term “coding” may be used as a concept including both coding performed by the encoding apparatus and decoding performed by the decoding apparatus.

[244] Table 4 shows the number of sub-blocks partitioned according to block sizes when ISP is applied, and sub-partitions partitioned according to ISP may be referred to as transform blocks (TUs).

[245] [Table 4]

| Block size (CU) | Number of partitions |
|-----------------|----------------------|
| 4x4 | not available |
| 4x8, 8x4 | 2 |
| All other cases | 4 |

[246] The ISP partitions a block predicted as luma intra into two or four sub-partitionings in a vertical direction or a horizontal direction according to the size of the block. For example, the minimum block size to which the ISP can be applied is 4 x 8 or 8 x 4. If the block size is greater than 4 x 8 or 8 x 4, the block is partitioned into four sub-partitionings.

[247] FIGS. 14 and 15 show an example of a sub-block into which one coding block is partitioned, and more specifically, FIG. 14 is an example of partition for a case in which a coding block (width (W) X height (H)) is a 4 x 8 block or an 8 x 4 block, and FIG. 15 shows an example of partition for a case in which a coding block is not a 4x8 block, nor an 8x4 block, nor a 4x4 block.

[248] When the ISP is applied, the sub-blocks are sequentially coded according to the partition type, such as, horizontally or vertically, from left to right, or from top to bottom, and coding for the next sub-block may be performed after performing up to a restoration process through inverse transform and intra prediction for one sub-block. For the leftmost or uppermost sub-block, as in a conventional intra prediction method, the reconstructed pixel of the coding block which has been already coded is referred to. Additionally, if the previous sub-block is not adjacent to each side of an internal sub-block that follows it, in order to derive reference

pixels adjacent to a corresponding side, as in the conventional intra prediction method, the reconstructed pixel of an already coded adjacent coding block is referred to.

[249] In the ISP coding mode, all sub-blocks may be coded with the same intra prediction mode, and a flag indicating whether or not to use the ISP coding and a flag indicating in which direction (horizontal or vertical) partition is to be performed may be signaled. As in FIGS. 14 and 15, the number of sub-blocks may be adjusted to 2 or 4 depending on the block shape, and when the size (width x height) of one sub-block is less than 16, the partition may not be allowed for the corresponding sub-blocks, nor the application of the ISP coding itself may be restricted.

[250] Meanwhile, in the case of ISP prediction mode, one coding unit is partitioned into two or four partition blocks, that is, sub-blocks, and predicted, and the same intra prediction mode is applied to the thus partitioned two or four partition blocks.

[251] As described above, both a horizontal direction (if an $M \times N$ coding unit having a horizontal length and a vertical length of M and N , respectively, is divided in the horizontal direction, it is divided into $M \times (N/2)$ blocks when divided into two, and into an $M \times (N/4)$ blocks when divided into four) and a vertical direction (if the $M \times N$ coding unit is divided in the vertical direction, it is divided into $(M/2) \times N$ blocks when divided into two, and divided into $(M/4) \times N$ blocks when divided into four) are possible as the partition direction. When partitioned in the horizontal direction, partition blocks are coded in an order from top to down, and when partitioned in the vertical direction, partition blocks are coded in an order from left to right. The currently coded partition block may be predicted by referring to the reconstructed pixel values of the top (left) partition block in the case of the horizontal (vertical) direction partition.

[252] Transformation may be applied to the residual signal generated by the ISP prediction method in units of partition blocks. MTS (Multiple Transform Selection) technology based on the DST-7/DCT-8 combination as well as the existing DCT-2 may be applied to the primary transform (core transform or primary transform) based on the forward direction, and an LFNST

(Low Frequency Non-Separable Transform) may be applied to a transform coefficient generated according to the primary transform to generate a final modified transform coefficient.

[253] That is, LFNST may also be applied to partition blocks divided by applying the ISP prediction mode, and the same intra prediction mode is applied to the divided partition blocks as described above. Accordingly, when selecting the LFNST set derived based on the intra prediction mode, the derived LFNST set may be applied to all partition blocks. That is, the same intra prediction mode is applied to all partition blocks, and thereby the same LFNST set may be applied to all partition blocks.

[254] Meanwhile, according to an example, the LFNST may be applied only to transform blocks having both a horizontal and vertical length of 4 or more. Therefore, when the horizontal or vertical length of the partition block partitioned according to the ISP prediction method is less than 4, the LFNST is not applied and the LFNST index is not signaled. Additionally, when the LFNST is applied to each partition block, the corresponding partition block may be regarded as one transform block. Of course, when the ISP prediction method is not applied, the LFNST may be applied to the coding block.

[255] Application of the LFNST to each partition block is described in detail as follows.

[256] According to an example, after applying the forward LFNST to an individual partition block, and after leaving only up to 16 coefficients (8 or 16) in the top-left 4x4 region according to the transform coefficient scanning order, zero-out of filling all remaining positions and regions with a value of 0 may be applied.

[257] Alternatively, according to an example, when the length of one side of the partition block is 4, the LFNST is applied only to the top-left 4x4 region, and when the length of all sides of the partition block, that is, the width and height, are 8 or more, the LFNST may be applied to the remaining 48 coefficients except for a bottom-right 4x4 region in a top-left 8x8 region.

[258] Alternatively, according to an example, in order to adjust the computational complexity of the worst case to 8 multiplications per sample, when each partition block is 4x4 or 8x8, only 8 transform coefficients may be output after applying the forward LFNST. That is, if the partition block is 4x4, an 8x16 matrix may be applied as a transform matrix, and if the partition block is 8x8, an 8x48 matrix may be applied as a transform matrix.

[259] Meanwhile, in the current VVC standard, LFNST index signaling is performed in units of coding units. Accordingly, when the ISP prediction mode is used and the LFNST is applied to all partition blocks, then the same LFNST index value may be applied to the corresponding partition blocks. That is, when the LFNST index value is transmitted once at the coding unit level, the corresponding LFNST index may be applied to all partition blocks in the coding unit. As described above, the LFNST index value may have values of 0, 1, and 2, 0 indicates a case in which the LFNST is not applied, and 1 and 2 indicate two transform matrices present in one LFNST set when the LFNST is applied.

[260] As described above, the LFNST set is determined by the intra prediction mode, and since all partition blocks in the coding unit are predicted in the same intra prediction mode in the case of the ISP prediction mode, the partition blocks may refer to the same LFNST set.

[261] As another example, the LFNST index signaling is still performed in units of coding units, but in the case of the ISP prediction mode, without determining whether or not to apply the LFNST uniformly to all partition blocks, whether to apply the LFNST index value signaled at the coding unit level to each partition block or not to apply the LFNST may be determined through a separate condition. Here, the separate condition may be signaled in the form of a flag for each partition block through the bitstream, and when the flag value is 1, the LFNST index value signaled at the coding unit level may be applied, and when the flag value is 0, the LFNST may not be applied.

[262] Meanwhile, in the coding unit to which the ISP mode is applied, an example of applying the LFNST when the length of one side of the partition block is less than 4 is discussed as follows.

[263] First, when the size of the partition block is $N \times 2$ ($2 \times N$), the LFNST may be applied to the top-left $M \times 2$ ($2 \times M$) region (here, $M \leq N$). For example, when $M = 8$, the corresponding top-left region becomes 8×2 (2×8), and thus, the region in which 16 residual signals exist may be the input of the forward LFNST, and the $R \times 16$ ($R \leq 16$) forward transformation matrix may be applied.

[264] Here, the forward LFNST matrix may not be the matrix included in the current VVC standard, but a separate additional matrix. In addition, for complexity adjustment of the worst case, an 8×16 matrix obtained by sampling only the upper 8 row vectors of the 16×16 matrix may be used for the transform. The complexity adjustment method will be described in detail later.

[265] Second, when the size of the partition block is $N \times 1$ ($1 \times N$), the LFNST may be applied to the top-left $M \times 1$ ($1 \times M$) region (here, $M \leq N$). For example, when $M = 16$, the corresponding top-left region becomes 16×1 (1×16), and thus, the region in which 16 residual signals exist may be the input of the forward LFNST, and the $R \times 16$ ($R \leq 16$) forward transformation matrix may be applied.

[266] Here, the corresponding forward LFNST matrix may not be the matrix included in the current VVC standard, but a separate additional matrix. In addition, for complexity adjustment of the worst case, an 8×16 matrix obtained by sampling only the upper 8 row vectors of the 16×16 matrix may be used for the transform. The complexity adjustment method will be described in detail later.

[267] The first embodiment and the second embodiment may be applied simultaneously, or either one of the two embodiments may be applied. In particular, in the case of the second embodiment, since the one-dimensional transform is considered in the LFNST, it was observed

through experiments that the compression performance improvement which could be obtained from the existing LFNST was not relatively great compared to the LFNST index signaling cost. However, in the case of the first embodiment, a compression performance improvement similar to that obtained from the conventional LFNST was observed, that is, in the case of ISP, it can be verified through experiments that the application of LFNST for $2 \times N$ and $N \times 2$ contributes to the actual compression performance.

[268] In the LFNST in the current VVC, symmetry between intra prediction modes is applied. The same LFNST set is applied to the two directional modes centered on mode 34 (prediction in the bottom-right 45 degree diagonal direction), and for example, the same LFNST set is applied to mode 18 (horizontal direction prediction mode) and mode 50 (vertical direction prediction mode). However, in modes 35 to 66, when the forward LFNST is applied, input data is transposed, and then the LFNST is applied.

[269] Meanwhile, VVC supports a Wide Angle Intra Prediction (WAIP) mode, and the LFNST set is derived based on the modified intra prediction mode in consideration of the WAIP mode. For the modes extended by WAIP, the LFNST set is also determined by utilizing symmetry as in the general intra prediction direction mode. For example, mode -1 is symmetric with mode 67, so the same LFNST set is applied, and mode -14 is symmetric with mode 80, so the same LFNST set is applied. Modes 67 to 80 apply LFNST transform after transposing input data before applying the forward LFNST.

[270] In the case of the LFNST applied to the top-left $M \times 2$ ($M \times 1$) block, the above-described symmetry to the LFNST cannot be applied, because the block to which the LFNST is applied is non-square. Therefore, instead of applying the symmetry based on the intra prediction mode as in the LFNST of Table 2, the symmetry between the $M \times 2$ ($M \times 1$) block and the $2 \times M$ ($1 \times M$) block may be applied.

[271] FIG. 16 is a diagram illustrating symmetry between an $M \times 2$ ($M \times 1$) block and a $2 \times M$ ($1 \times M$) block according to an example.

[272] As shown in Figure 16, mode 2 in the $M \times 2$ ($M \times 1$) block can be regarded as symmetric with mode 66 in the $2 \times M$ ($1 \times M$) block, and thus, the same LFNST set may be applied to the $2 \times M$ ($1 \times M$) block and the $M \times 2$ ($M \times 1$) block.

[273] At this time, in order to apply the LFNST set, which has been applied to the $M \times 2$ ($M \times 1$) block, to the $2 \times M$ ($1 \times M$) block, the LFNST set is selected based on the mode 2 instead of the mode 66. That is, before applying the forward LFNST, it is possible to apply the LFNST after transposing the input data of the $2 \times M$ ($1 \times M$) block.

[274] FIG. 17 is a diagram illustrating an example of transposing a $2 \times M$ block according to an example.

[275] FIG. 17A is a diagram illustrating that the LFNST can be applied by reading input data in a column-first order with respect to a $2 \times M$ block, and FIG. 17B is a diagram illustrating that the LFNST is applied by reading input data in a row-first order with respect to an $M \times 2$ ($M \times 1$) block. The method of applying the LFNST to the top-left $M \times 2$ ($M \times 1$) or $2 \times M$ ($M \times 1$) block is summarized as follows.

[276] 1. First, as shown in FIGS. 17A and 17B, input data is arranged to construct an input vector of the forward LFNST. For example, referring to FIG. 16, for the $M \times 2$ block predicted in mode 2, the order in FIG. 17(b) is followed, and for a $2 \times M$ block predicted in the mode 66, after arranging input data according to the order of FIG. 17(a), the LFNST set for mode 2 may be applied.

[277] 2. For the $M \times 2$ ($M \times 1$) block, the LFNST set is determined based on the modified intra prediction mode in consideration of the WAIP. As described above, a predetermined mapping relationship is established between the intra prediction mode and the LFNST set, and may be represented by a mapping table as shown in Table 2.

[278] For a $2 \times M$ ($1 \times M$) block, after obtaining a symmetrical mode with respect to the prediction mode (mode 34 in the case of the VVC standard) in a right downward 45 degree diagonal direction from the intra prediction mode modified in consideration of the WAIP, the

LFNST set is determined based on the corresponding symmetric mode and the mapping table. A symmetrical mode (y) with respect to mode 34 may be derived through the following equation. The mapping table is described in more detail below.

[279] [Equation 11]

$$\text{if } 2 \leq x \leq 66, y = 68 - x,$$

$$\text{otherwise } (x \leq -1 \text{ or } x \geq 67), y = 66 - x$$

[280] 3. When the forward LFNST is applied, the transform coefficient may be derived by multiplying the input data prepared through process 1 by the LFNST kernel. The LFNST kernel may be selected from the LFNST set determined in process 2 and a predetermined LFNST index.

[281] For example, if $M = 8$ and a 16×16 matrix is applied as the LFNST kernel, then 16 transform coefficients may be generated by multiplying the matrix by 16 input data. The generated transform coefficients may be arranged in the top-left 8×2 or 2×8 region according to the scanning order used in the VVC standard.

[282] FIG. 18 shows a scanning order for an 8×2 or 2×8 region according to an example.

[283] All regions other than the top-left 8×2 or 2×8 region may be filled with zero values (zero-out) or the existing transform coefficient to which the primary transform has been applied may be maintained as it is. The predetermined LFNST index may be one of the LFNST index values (0, 1, 2) attempted when calculating the RD cost while changing the LFNST index value in the encoding process.

[284] For a configuration that brings the worst-case computational complexity below a certain level (e.g. 8 multiplications/sample), for example, after generating only eight transform coefficients by multiplying an 8×16 matrix obtained by taking only the upper eight rows of the 16×16 matrix, the eight transform coefficients may be arranged according to the scanning order as shown in FIG. 18, and zero-out may also be applied to the remaining coefficient regions. The complexity adjustment for the worst case will be described later.

[285] 4. When applying the backward LFNST, a predetermined number (e.g., 16) of transform coefficients is set as an input vector, and after selecting the LFNST kernel (e.g., 16x16 matrix) derived from the LFNST set obtained from process 2 and the parsed LFNST index, the output vector may be derived by multiplying the LFNST kernel and the input vector.

[286] In the case of an $M \times 2$ ($M \times 1$) block, the output vector may be arranged according to the row-first order as shown in FIG. 17B, and in the case of a $2 \times M$ ($1 \times M$) block, the output vector may be arranged according to the column-first order as shown in FIG. 17A.

[287] For the remaining area except for the area where the corresponding output vector is arranged in the top-left $M \times 2$ ($M \times 1$) or $2 \times M$ ($M \times 2$) region, and for a region other than the top-left $M \times 2$ ($M \times 1$) or $2 \times M$ ($M \times 2$) region in the partition block, all of them may be configured to be filled with zero values (zero-out) or to maintain the transform coefficient reconstructed through residual coding and dequantization processes as it is.

[288] As in No. 3, when constructing the input vector, the input data may be arranged according to the scanning order of FIG. 18, and an input vector may be constructed with the reduced number of input data (e.g., 8 instead of 16) in order to adjust the computational complexity for the worst case to a certain level or less.

[289] For example, when using 8 input data and when $M = 8$, only the left 16x8 matrix may be taken from the corresponding 16x16 matrix, and be multiplied, thereby obtaining 16 output data. The complexity adjustment for the worst case will be described later.

[290] While the above embodiment presents a case in which symmetry is applied between an $M \times 2$ ($M \times 1$) block and a $2 \times M$ ($1 \times M$) block when applying LFNST, different LFNST sets may be applied to the two block shapes, respectively, according to another example.

[291] Hereinafter, various examples of the LFNST set configuration for the ISP mode and the mapping method using the intra prediction mode will be described.

[292] In the case of ISP mode, the LFNST set configuration may be different from that of the existing LFNST set. In other words, kernels different from the existing LFNST kernels may

be applied, and a mapping table different from the mapping table between the intra prediction mode index applied to the current VVC standard and the LFNST set may be applied. The mapping table applied to the current VVC standard may be shown in Table 2.

[293] In Table 2, the `predModeIntra` value means an intra prediction mode value changed in consideration of the WAIP, and the `lfnstTrSetIdx` value is an index value indicating a specific LFNST set. Each LFNST set is configured with two LFNST kernels.

[294] When the ISP prediction mode is applied, and when both the horizontal length and the vertical length of each partition block are equal to or greater than 4, the same kernels as the LFNST kernels applied in the current VVC standard may be applied, and the mapping table may be also applied as it is. Of course, it is also possible to apply a different mapping table and different LFNST kernels from the current VVC standard.

[295] When the ISP prediction mode is applied, and when the horizontal length or the vertical length of each partition block is less than 4, a different mapping table and different LFNST kernels from the current VVC standard may be applied. Hereinafter, Tables 5 to 7 show mapping tables between an intra prediction mode value (intra prediction mode value changed in consideration of the WAIP) and an LFNST set, which may be applied to an $M \times 2$ ($M \times 1$) block or a $2 \times M$ ($1 \times M$) block.

[296] [Table 5]

| predModeIntra | lfnstTrSetIdx |
|--|----------------------|
| <code>predModeIntra < 0</code> | 1 |
| <code>0 <= predModeIntra <= 1</code> | 0 |
| <code>2 <= predModeIntra <= 12</code> | 1 |
| <code>13 <= predModeIntra <= 23</code> | 2 |
| <code>24 <= predModeIntra <= 34</code> | 3 |
| <code>35 <= predModeIntra <= 44</code> | 4 |
| <code>45 <= predModeIntra <= 55</code> | 5 |
| <code>56 <= predModeIntra <= 66</code> | 6 |
| <code>67 <= predModeIntra <= 80</code> | 6 |
| <code>81 <= predModeIntra <= 83</code> | 0 |

[297] [Table 6]

| predModeIntra | lfnstTrSetIdx |
|---------------------------|----------------------|
| predModeIntra < 0 | 1 |
| 0 <= predModeIntra <= 1 | 0 |
| 2 <= predModeIntra <= 23 | 1 |
| 24 <= predModeIntra <= 44 | 2 |
| 45 <= predModeIntra <= 66 | 3 |
| 67 <= predModeIntra <= 80 | 3 |
| 81 <= predModeIntra <= 83 | 0 |

[298] [Table 7]

| predModeIntra | lfnstTrSetIdx |
|---------------------------|----------------------|
| predModeIntra < 0 | 1 |
| 0 <= predModeIntra <= 1 | 0 |
| 2 <= predModeIntra <= 80 | 1 |
| 81 <= predModeIntra <= 83 | 0 |

[299] The first mapping table of Table 5 includes seven LFNST sets, and the mapping table of Table 6 includes four LFNST sets, and the mapping table of Table 7 includes two LFNST sets. As another example, when configured with one LFNST set, the lfnstTrSetIdx value may be fixed to 0 with respect to the preModeIntra value.

[300] Hereinafter, a method for maintaining the computational complexity for the worst case when LFNST is applied to the ISP mode will be described.

[301] In the case of ISP mode, in order to maintain the number of multiplications per sample (or per coefficient, or per position) at a certain value or less when LFNST is applied, the application of LFNST may be restricted. Depending on the size of the partition block, the number of multiplications per sample (or per coefficient, or per position) may be maintained at 8 or less by applying LFNST as follows.

[302] 1. When both the horizontal length and the vertical length of the partition block are equal to or greater than 4, the same method as the calculation complexity adjustment method for the worst case for LFNST in the current VVC standard may be applied.

[303] That is, when the partition block is a 4x4 block, instead of a 16x16 matrix, in the forward direction, an 8x16 matrix obtained by sampling the top 8 rows from a 16x16 matrix may be applied, and in the backward direction, a 16x8 matrix obtained by sampling the left 8 columns from a 16x16 matrix may be applied. Additionally, when the partition block is an 8x8 block, in the forward direction, instead of a 16x48 matrix, an 8x48 matrix obtained by sampling the top 8 rows from a 16x48 matrix may be applied, and in the backward direction, instead of a 48x16 matrix, a 48x8 matrix obtained by sampling the left 8 columns from a 48x16 matrix may be applied.

[304] In the case of a 4xN or Nx4 ($N > 4$) block, when forward transform is performed, 16 coefficients generated after applying a 16x16 matrix only to the top-left 4x4 block are arranged in the top-left 4x4 region, and the other regions may be filled with 0 values. Additionally, when performing inverse transform, 16 coefficients located in the top-left 4x4 block may be arranged in the scanning order to configure an input vector, and then 16 output data may be generated by multiplying the 16x16 matrix. The generated output data may be arranged in the top-left 4x4 region, and the remaining regions except for the top-left 4x4 region may be filled with zeros.

[305] In the case of an 8xN or Nx8 ($N > 8$) block, when the forward transformation is performed, 16 coefficients generated after applying the 16x48 matrix only to the ROI region in the top-left 8x8 block (remaining regions excluding the bottom-right 4x4 block from the top-left 8x8 block) may be arranged in the top-left 4x4 area, and the other regions may be filled with 0 values. Additionally, when performing inverse transform, 16 coefficients located in the top-left 4x4 block may be arranged in the scanning order to configure an input vector, and then 48 output data may be generated by multiplying the 48x16 matrix. The generated output data may be filled in the ROI region, and the other regions may be filled with 0 values.

[306] 2. When the size of the partition block is $N \times 2$ or $2 \times N$ and the LFNST is applied to the top-left $M \times 2$ or $2 \times M$ region ($M \leq N$), a matrix to which the sampling has been applied according to the N value may be applied.

[307] When $M = 8$, for a partition block of $N = 8$, that is, an 8×2 or 2×8 block, in the case of forward transform, instead of a 16×16 matrix, an 8×16 matrix obtained by sampling top 8 rows from a 16×16 matrix may be applied, and in the case of the inverse transform, instead of a 16×16 matrix, a 16×8 matrix obtained by sampling the left 8 columns from a 16×16 matrix may be applied.

[308] When N is greater than 8, in the case of forward transform, 16 output data generated after applying the 16×16 matrix to the top-left 8×2 or 2×8 block may be arranged in the top-left 8×2 or 2×8 block, and the remaining regions may be filled with 0 values. When performing inverse transform, 16 coefficients located in the top-left 8×2 or 2×8 block may be arranged in the scanning order to configure an input vector, and then 16 output data may be generated by multiplying the 16×16 matrix. The generated output data may be arranged in the top-left 8×2 or 2×8 block, and all the remaining regions may be filled with 0 values.

[309] 3. When the size of the partition block is $N \times 1$ or $1 \times N$ and the LFNST is applied to the top-left $M \times 1$ or $1 \times M$ region ($M \leq N$), a matrix to which the sampling has been applied according to the N value may be applied.

[310] When $M = 16$, for a partition block of $N = 16$, that is, an 16×1 or 1×16 block, in the case of forward transform, instead of a 16×16 matrix, an 8×16 matrix obtained by sampling top 8 rows from a 16×16 matrix may be applied, and in the case of the inverse transform, instead of a 16×16 matrix, a 16×8 matrix obtained by sampling the left 8 columns from a 16×16 matrix may be applied.

[311] When N is greater than 16, in the case of forward transform, 16 output data generated after applying the 16×16 matrix to the top-left 16×1 or 1×16 block may be arranged in the top-left 16×1 or 1×16 block, and the remaining regions may be filled with 0 values. When

performing inverse transform, 16 coefficients located in the top-left 16x1 or 1x16 block may be arranged in the scanning order to configure an input vector, and then 16 output data may be generated by multiplying the 16x16 matrix. The generated output data may be arranged in the top-left 16x1 or 1x16 block, and all the remaining regions may be filled with 0 values.

[312] As another example, in order to maintain the number of multiplications per sample (or per coefficient, or per position) at a certain value or less, the number of multiplications per sample (or per coefficient, or per position) based on the ISP coding unit size rather than the size of the ISP partition block may be maintained at 8 or less. If there is only one block among the ISP partition blocks, which satisfies the condition under which the LFNST is applied, the complexity calculation for the worst case of LFNST may be applied based on the corresponding coding unit size rather than the size of the partition block. For example, when a luma coding block for a certain coding unit is partitioned into 4 partition blocks of 4x4 size and coded by the ISP, and when no non-zero transform coefficient exists for two partition blocks among them, the other two partition blocks may be respectively set to generate 16 transform coefficients instead of 8 (based on the encoder).

[313] Hereinafter, a method of signaling the LFNST index in the case of the ISP mode will be described.

[314] As described above, the LFNST index may have values of 0, 1, and 2, where 0 indicates that the LFNST is not applied, and 1 and 2 respectively indicate either one of two LFNST kernel matrices included in the selected LFNST set. The LFNST is applied based on the LFNST kernel matrix selected by the LFNST index. A method of transmitting the LFNST index in the current VVC standard will be described as follows.

[315] 1. An LFNST index may be transmitted once for each coding unit (CU), and in the case of a dual-tree, individual LFNST indexes may be signaled for a luma block and a chroma block, respectively.

[316] 2. When the LFNST index is not signaled, the LFNST index value is inferred to be a default value of 0. The case where the LFNST index value is inferred to be 0 is as follows.

[317] A. In the case of a mode in which no transform is applied (e.g., transform skip, BDPCM, lossless coding, etc.)

[318] B. When the primary transform is not DCT-2 (DST7 or DCT8), that is, when the transform in the horizontal direction or the transform in the vertical direction is not DCT-2

[319] C. When the horizontal length or vertical length for the luma block of the coding unit exceeds the size of the transformable maximum luma transform, for example, when the size of the transformable maximum luma transform is 64, and when the size for the luma block of the coding block is equal to 128x16, the LFNST cannot be applied.

[320] In the case of the dual tree, it is determined whether or not the size of the maximum luma transform is exceeded for each of the coding unit for the luma component and the coding unit for the chroma component. That is, it is checked for the luma block whether or not the size of the maximum transformable luma transform is exceeded, and it is checked for the chroma block whether or not the horizontal/vertical length of the corresponding luma block for the color format and the size of the maximum transformable luma transform exceed the size are exceeded. For example, when the color format is 4:2:0, the horizontal/vertical length of the corresponding luma block is twice that of the corresponding chroma block, and the transform size of the corresponding luma block is twice that of the corresponding chroma block. As another example, when the color format is 4:4:4, the horizontal/vertical length and transform size and of the corresponding luma block are the same as those of the corresponding chroma block.

[321] A 64-length transform or a 32-length transform may mean a transform applied to width or height having a length of 64 or 32, respectively, and “transform size” may mean 64 or 32 as the corresponding length.

[322] In the case of a single tree, after checking whether or not a horizontal length or a vertical length of a luma block exceeds the maximum transformable luma transform block size, if it exceeds, the LFNST index signaling may be omitted.

[323] D. The LFNST index may be transmitted only when both the horizontal length and the vertical length of the coding unit are equal to or greater than 4.

[324] In the case of a dual tree, the LFNST index may be signaled only when both the horizontal and vertical lengths for a corresponding component (i.e., a luma or chroma component) are equal to or greater than 4.

[325] In the case of a single tree, the LFNST index may be signaled when both the horizontal and vertical lengths for the luma component are equal to or greater than 4.

[326] E. If the position of the last non-zero coefficient is not a DC position (top-left position of the block), and if the position of the last non-zero coefficient is not a DC position, in the case of a luma block of a dual tree type, the LFNST index is transmitted. In the case of a dual tree type chroma block, if any one of the position of the last non-zero coefficient for Cb and the position of the last non-zero coefficient for Cr is not a DC position, the corresponding LFNST index is transmitted.

[327] In the case of the single tree type, if the position of the last non-zero coefficient of any one of the luma component, Cb component, and Cr component is not the DC position, the LFNST index is transmitted.

[328] Here, if a coded block flag (CBF) value indicating whether or not a transform coefficient for one transform block exists is 0, the position of the last non-zero coefficient for the corresponding transform block is not checked in order to determine whether or not the LFNST index is signaled. That is, when the corresponding CBF value is 0, since no transform is applied to the corresponding block, the position of the last non-zero coefficient may not be considered when checking the condition for the LFNST index signaling.

[329] For example, 1) in the case of a dual tree type and a luma component, if the corresponding CBF value is 0, the LFNST index is not signaled, 2) in the case of a dual tree type and chroma component, if the CBF value for Cb is 0 and the CBF value for Cr is 1, only the position of the last non-zero coefficient for Cr is checked and the corresponding LFNST index is transmitted, 3) in the case of a single tree type, the position of the last non-zero coefficient is checked only for components having a CBF value of 1 for each of luma, Cb, and Cr.

[330] F. When it is confirmed that the transform coefficient exists at a position other than a position where the LFNST transform coefficient may exist, the LFNST index signaling may be omitted. In the case of a 4x4 transform block and an 8x8 transform block, LFNST transform coefficients may exist at eight positions from the DC position according to the transform coefficient scanning order in the VVC standard, and the remaining positions are filled with zeros. Additionally, when the 4x4 transform block and the 8x8 transform block are not, LFNST transform coefficients may exist in sixteen positions from the DC position according to the transform coefficient scanning order in the VVC standard, and the remaining positions are filled with zeros.

[331] Accordingly, if the non-zero transform coefficients exists in the region which should be filled with the zero value after progressing the residual coding, the LFNST index signaling may be omitted.

[332] Meanwhile, the ISP mode may also be applied only to the luma block, or may be applied to both the luma block and the chroma block. As described above, when ISP prediction is applied, the corresponding coding unit may be divided into two or four partition blocks and predicted, and a transform may be applied to each of the partition blocks. Therefore, also when determining a condition for signaling the LFNST index in units of coding units, it is necessary to take into consideration the fact that the LFNST may be applied to respective partition blocks. In addition, when the ISP prediction mode is applied only to a specific component (e.g., a luma

block), the LFNST index must be signaled in consideration of the fact that only the component is divided into partition blocks. The LFNST index signaling methods available in the ISP mode are summarized as follows.

[333] 1. An LFNST index may be transmitted once for each coding unit (CU), and in the case of a dual-tree, individual LFNST indexes may be signaled for a luma block and a chroma block, respectively.

[334] 2. When the LFNST index is not signaled, the LFNST index value is inferred to be a default value of 0. The case where the LFNST index value is inferred to be 0 is as follows.

[335] A. In the case of a mode in which no transform is applied (e.g., transform skip, BDPCM, lossless coding, etc.)

[336] B. When the horizontal length or vertical length for the luma block of the coding unit exceeds the size of the transformable maximum luma transform, for example, when the size of the transformable maximum luma transform is 64, and when the size for the luma block of the coding block is equal to 128x16, the LFNST cannot be applied.

[337] Whether or not to signal the LFNST index may be determined based on the size of the partition block instead of the coding unit. That is, if the horizontal or vertical length of the partition block for the corresponding luma block exceeds the size of the transformable maximum luma transformation, the LFNST index signaling may be omitted and the LFNST index value may be inferred to be 0.

[338] In the case of the dual tree, it is determined whether or not the size of the maximum luma transform is exceeded for each of the coding unit or partition block for the luma component and the coding unit or partition block for the chroma component. That is, if the horizontal and vertical lengths of the coding unit or partition block for luma are compared with the maximum luma transform size, respectively, and at least one of them is greater than the maximum luma transform size, the LFNST is not applied, and in the case of a coding unit or partition block for chroma, the horizontal/vertical length of the corresponding luma block for

the color format and the size of the maximum transformable luma transform are compared. For example, when the color format is 4:2:0, the horizontal/vertical length of the corresponding luma block is twice that of the corresponding chroma block, and the transform size of the corresponding luma block is twice that of the corresponding chroma block. As another example, when the color format is 4:4:4, the horizontal/vertical length and transform size and of the corresponding luma block are the same as those of the corresponding chroma block.

[339] In the case of a single tree, after checking whether or not a horizontal length or a vertical length for a luma block (coding unit or partition block) exceeds the maximum transformable luma transform block size, if it exceeds, the LFNST index signaling may be omitted.

[340] C. If the LFNST included in the current VVC standard is applied, the LFNST index may be transmitted only when both the horizontal length and the vertical length of the partition block are equal to or greater than 4.

[341] If the LFNST for the $2 \times M$ ($1 \times M$) or $M \times 2$ ($M \times 1$) block is applied in addition to the LFNST included in the current VVC standard, the LFNST index may be transmitted only when the size of the partition block is equal to or larger than a $2 \times M$ ($1 \times M$) or $M \times 2$ ($M \times 1$) block. Here, the expression “the $P \times Q$ block is equal to or greater than the $R \times S$ block” means that $P \geq R$ and $Q \geq S$.

[342] In summary, the LFNST index can be transmitted only when the partition block is equal to or greater than the minimum size to which the LFNST is applicable. In the case of a dual tree, the LFNST index can be signaled only when the partition block for the luma or chroma component is equal to or larger than the minimum size to which the LFNST is applicable. In the case of a single tree, the LFNST index can be signaled only when the partition block for the luma component is equal to or larger than the minimum size to which LFNST is applicable.

[343] In this document, the expression “the MxN block is greater than or equal to the KxL block” means that M is greater than or equal to K and N is greater than or equal to L. The expression “the MxN block is larger than the KxL block” means that M is greater than or equal to K and N is greater than or equal to L, and that M is greater than K or N is greater than L. The expression “the MxN block less than or equal to the KxL block” means that M is less than or equal to K and N is less than or equal to L, while the expression “the MxN block is smaller than the KxL block” means that M is less than or equal to K and N is less than or equal to L, and that M is less than K or N is less than L.

[344] D. If the position of the last non-zero coefficient is not a DC position (top-left position of the block), and if the position of the last non-zero coefficient is not a DC position in any one of all partition blocks In the case of a dual tree type luma block, the LFNST index is transmitted. In the case of a dual tree type and a chroma block, if at least one of the position of the last non-zero coefficient of all partition blocks for Cb (if the ISP mode is not applied to the chroma component, the number of partition blocks is considered to be one) and the position of the last non-zero coefficient of all partition blocks for Cr (if the ISP mode is not applied to the chroma component, the number of partition blocks is considered to be one) is not a DC position, the corresponding LNFST index may be transmitted.

[345] In the case of the single tree type, if the position of the last non-zero coefficient of any one of all partition blocks for the luma component, the Cb component and the Cr component is not the DC position, the corresponding LFNST index may be transmitted.

[346] Here, if the value of the coded block flag (CBF) indicating whether a transform coefficient exists for each partition block is 0, the position of the last non-zero coefficient for the corresponding partition block is not checked in order to determine whether or not the LFNST index is signaled. That is, when the corresponding CBF value is 0, since no transform is applied to the corresponding block, the position of the last non-zero coefficient for the

corresponding partition block is not considered when checking the condition for the LFNST index signaling.

[347] For example, 1) in the case of a dual tree type and a luma component, if the corresponding CBF value for each partition block is 0, the partition block is excluded when determining whether or not to signal the LFNST index, 2) in the case of a dual tree type and a chroma component, if the CBF value for Cb is 0 and the CBF value for Cr is 1 for each partition block, only the position of the last non-zero coefficient for Cr is checked to determine whether or not to signal the LFNST index, 3) in the case of the single tree type, it is possible to determine whether or not to signal the LFNST index by checking the position of the last non-zero coefficient only for blocks having a CBF value of 1 for all partition blocks of the luma component, the Cb component, and the Cr component.

[348] In the case of the ISP mode, image information may also be configured so that the position of the last non-zero coefficient is not checked, and an embodiment thereof is as follows.

[349] i. In the case of the ISP mode, the LFNST index signaling may be allowed without checking the position of the last non-zero coefficient for both the luma block and the chroma block. That is, even if the position of the last non-zero coefficient for all partition blocks is the DC position or the corresponding CBF value is 0, the LFNST index signaling may be allowed.

[350] ii. In the case of the ISP mode, the checking of the position of the last non-zero coefficient only for the luma block may be omitted, and in the case of the chroma block, the checking of the position of the last non-zero coefficient may be performed in the above-described manner. For example, in the case of a dual tree type and a luma block, the LFNST index signaling is allowed without checking the position of the last non-zero coefficient, and in the case of a dual tree type and a chroma block, whether or not a corresponding LFNST index is signaled may be determined by checking whether or not a DC position exists for the position of the last non-zero coefficient in the above-described manner.

[351] iii. In the case of the ISP mode and the single tree type, the i or ii method may be applied. That is, in the case of the ISP mode and when the number i is applied to the single tree type, it is possible to omit the checking of the position of the last non-zero coefficient for both the luma block and the chroma block and allow LFNST index signaling. Alternatively, by applying section ii, for the partition blocks for the luma component, the checking of the position of the last non-zero coefficient is omitted, and for the partition blocks for the chroma component (if ISP is not applied for the chroma component, the number of partition blocks can be considered as 1), the position of the last non-zero coefficient is checked in the above-described manner, thereby determining whether or not to signal the LFNST index.

[352] E. When it is confirmed that the transform coefficient exists at a position other than a position where the LFNST transform coefficient may exist even for one partition block among all partition blocks, the LFNST index signaling may be omitted.

[353] For example, in the case of a 4x4 partition block and an 8x8 partition block, LFNST transform coefficients may exist at eight positions from the DC position according to the transform coefficient scanning order in the VVC standard, and the remaining positions are filled with zeros. Additionally, if it is equal to or greater than 4x4 and is not a 4x4 partition block nor an 8x8 partition block, LFNST transform coefficients may exist at 16 positions from the DC position according to the transform coefficient scanning order in the VVC standard, and all the remaining positions are filled with zeros.

[354] Accordingly, if the non-zero transform coefficients exists in the region which should be filled with the zero value after progressing the residual coding, the LFNST index signaling may be omitted.

[355] If the LFNST can be applied even when the partition block is 2xM (1xM) or Mx2 (Mx1), a region in which LFNST transform coefficients may be located can be designated as follows. If a region other than the region where the transform coefficients can be located may

be filled with 0, and if a non-zero transform coefficient exists in the region that should be filled with 0 when it is assumed that LFNST is applied, the LFNST index signaling may be omitted.

[356] i. If the LFNST may be applied to a $2 \times M$ or $M \times 2$ block and $M = 8$, only 8 LFNST transform coefficients may be generated for a 2×8 or 8×2 partition block. When the transform coefficients are arranged in the scanning order as shown in FIG. 18, 8 transform coefficients are arranged in the scanning order from the DC position, and the remaining 8 positions may be filled with zeros.

[357] For a $2 \times N$ or $N \times 2$ ($N > 8$) partition block, 16 LFNST transform coefficients can be generated, and when the transform coefficients are arranged in the scanning order as shown in FIG. 18, 16 transform coefficients are arranged in the scanning order from the DC position, and the remaining region may be filled with zeros. That is, in a $2 \times N$ or $N \times 2$ ($N > 8$) partition block, a region other than the top-left 2×8 or 8×2 block may be filled with zeros. Even for a 2×8 or 8×2 partition block, 16 transform coefficients may be generated instead of 8 LFNST transform coefficients, and in this case, a region that must be filled with zeros does not occur. As described above, when the LFNST is applied, and when it is detected that a non-zero transform coefficient exists in a region determined to be filled with 0 in at least one partition block, LFNST index signaling may be omitted and the LFNST index may be inferred to be 0.

[358] ii. If the LFNST may be applied to a $1 \times M$ or $M \times 1$ block and $M = 16$, only 8 LFNST transform coefficients may be generated for a 1×16 or 16×1 partition block. When the transform coefficients are arranged in left-to-right or top-to-bottom scanning order, 8 transform coefficients are arranged in the corresponding scanning order from the DC position, and the remaining 8 positions may be filled with zeros.

[359] For a $1 \times N$ or $N \times 1$ ($N > 16$) partition block, 16 LFNST transform coefficients can be generated, and when the transform coefficients are arranged in left-to-right or top-to-bottom scanning order, 16 transform coefficients are arranged in the corresponding scanning order from the DC position, and the remaining region may be filled with zeros. That is, in a $1 \times N$ or

$N \times 1$ ($N > 16$) partition block, a region other than the top-left 1×16 or 16×1 block may be filled with zeros.

[360] Even for a 1×16 or 16×1 partition block, 16 transform coefficients may be generated instead of 8 LFNST transform coefficients, and in this case, a region that must be filled with zeros does not occur. As described above, when the LFNST is applied, and when it is detected that a non-zero transform coefficient exists in a region determined to be filled with 0 in at least one partition block, LFNST index signaling may be omitted and the LFNST index may be inferred to be 0.

[361] Meanwhile, in the case of the ISP mode, the length condition is independently viewed for the horizontal direction and the vertical direction, and DST-7 is applied instead of DCT-2 without signaling for the MTS index. It is determined whether or not the horizontal or vertical length is greater than or equal to 4 and less than or equal to 16, and a primary transform kernel is determined according to the determination result. Accordingly, in the case of the ISP mode, when the LFNST can be applied, the following transform combination configuration is possible.

[362] 1. When the LFNST index is 0 (including the case in which the LFNST index is inferred as 0), the primary transform decision condition at the time of the ISP included in the current VVC standard may be followed. In other words, it may be checked whether or not the length condition (being equal to or greater than 4 or equal to or less than 16) is independently satisfied for the horizontal and vertical directions, respectively, and if it is satisfied, DST-7 may be applied instead of DCT-2 for primary transform, while, if it is not satisfied, DCT-2 may be applied.

[363] 2. For a case in which the LFNST index is greater than 0, the following two configurations may be possible as a primary transform.

[364] A. DCT-2 can be applied to both horizontal and vertical directions.

[365] B. The primary transform decision condition at the time of the ISP included in the current VVC standard may be followed. In other words, it may be checked whether or not

the length condition (being equal to or greater than 4 or equal to or less than 16) is independently satisfied for the horizontal and vertical directions, respectively, and if it is satisfied, DST-7 may be applied instead of DCT-2, while, if it is not satisfied, DCT-2 may be applied.

[366] In the ISP mode, image information may be configured such that the LFNST index is transmitted for each partition block rather than for each coding unit. In this case, in the above-described LFNST index signaling method, it may be regarded that only one partition block exists in a unit in which the LFNST index is transmitted, and it may be determined whether or not to signal the LFNST index.

[367] Meanwhile, the signaling order of the LFNST index and the MTS index will be described below.

[368] According to an example, the LFNST index signaled in residual coding may be coded after the coding position for the last non-zero coefficient position, and the MTS index may be coded immediately after the LFNST index. In the case of this configuration, the LFNST index may be signaled for each transform unit. Alternatively, even if not signaled in residual coding, the LFNST index may be coded after the coding for the last significant coefficient position, and the MTS index may be coded after the LFNST index.

[369] The syntax of residual coding according to an example is as follows.

[370] [Table 8]

| |
|---|
| residual_coding(x0, y0, log2TbWidth, log2TbHeight, cIdx) { |
| if((sps_mts_enabled_flag && cu_sbt_flag && log2TbWidth < 6 && log2TbHeight < 6) && cIdx == 0 && log2TbWidth > 4) |
| log2ZoTbWidth = 4 |
| else |
| log2ZoTbWidth = Min(log2TbWidth, 5) |
| MaxCbcs = 2 * (1 << log2TbWidth) * (1 << log2TbHeight) |
| if((sps_mts_enabled_flag && cu_sbt_flag && log2TbWidth < 6 && log2TbHeight < 6) && cIdx == 0 && log2TbHeight > 4) |
| log2ZoTbHeight = 4 |
| else |
| log2ZoTbHeight = Min(log2TbHeight, 5) |
| if(log2TbWidth > 0) |
| last_sig_coeff_x_prefix |
| if(log2TbHeight > 0) |
| last_sig_coeff_y_prefix |
| if(last_sig_coeff_x_prefix > 3) |
| last_sig_coeff_x_suffix |
| if(last_sig_coeff_y_prefix > 3) |
| last_sig_coeff_y_suffix |
| remBinsPass1 = ((1 << (log2TbWidth + log2TbHeight)) * 7) >> 2 |
| log2SbW = (Min(log2TbWidth, log2TbHeight) < 2 ? 1 : 2) |
| log2SbH = log2SbW |
| if(log2TbWidth + log2TbHeight > 3) { |
| if(log2TbWidth < 2) { |
| log2SbW = log2TbWidth |
| log2SbH = 4 - log2SbW |
| } else if(log2TbHeight < 2) { |
| log2SbH = log2TbHeight |
| log2SbW = 4 - log2SbH |
| } |
| } |
| numSbCoeff = 1 << (log2SbW + log2SbH) |
| lastScanPos = numSbCoeff |
| lastSubBlock = (1 << (log2TbWidth + log2TbHeight - (log2SbW + log2SbH))) - 1 |
| do { |

2026201822

11 Mar 2026

[371]

| |
|--|
| if(lastScanPos == 0) { |
| lastScanPos = numSbCoeff |
| lastSubBlock-- |
| } |
| lastScanPos-- |
| xS = DiagScanOrder[log2TbWidth - log2SbW][log2TbHeight - log2SbH] |
| [lastSubBlock][0] |
| yS = DiagScanOrder[log2TbWidth - log2SbW][log2TbHeight - log2SbH] |
| [lastSubBlock][1] |
| xC = (xS << log2SbW) + DiagScanOrder[log2SbW][log2SbH][lastScanPos][0] |
| yC = (yS << log2SbH) + DiagScanOrder[log2SbW][log2SbH][lastScanPos][1] |
| } while((xC != LastSignificantCoefX) (yC != LastSignificantCoefY)) |
| cbWidth = CbWidth[0][x0][y0] |
| cbHeight = CbHeight[0][x0][y0] |
| if(Min(log2TbWidth, log2TbHeight) >= 2 && sps_lfnst_enabled_flag == 1 |
| && |
| CuPredMode[chType][x0][y0] == MODE_INTRA && |
| IntraSubPartitionsSplit[x0][y0] == ISP_NO_SPLIT && |
| (!intra_mip_flag[x0][y0] Min(log2TbWidth, log2TbHeight) >= 4) && |
| Max(cbWidth, cbHeight) <= MaxTbSizeY && |
| (cIdx == 0 (treeType == DUAL_TREE_CHROMA && |
| (cIdx == 1 tu_cbf_cb[x0][y0] == 0))) { |
| if(lastSubBlock == 0 && lastScanPos > 0 && |
| !(lastScanPos > 7 && (log2TbWidth == 2 log2TbWidth == 3) |
| && log2TbWidth == log2TbHeight) |
| lfnst_idx [x0][y0] |
| } |
| if(cIdx == 0 && lfnst_idx[x0][y0] == 0 && |
| (log2TbWidth <= 5) && (log2TbHeight <= 5) && |
| (LastSignificantCoefX < 16) && (LastSignificantCoefY < 16) && |
| (IntraSubPartitionsSplit[x0][y0] == ISP_NO_SPLIT) && (!cu_sbt_flag)) { |
| if(((CuPredMode[chType][x0][y0] == MODE_INTER && |
| sps_explicit_mts_inter_enabled_flag) |
| (CuPredMode[chType][x0][y0] == MODE_INTRA && |
| sps_explicit_mts_intra_enabled_flag)) |
| tu_mts_idx [x0][y0] |
| } |
| if(tu_mts_idx[x0][y0] > 0 && cIdx == 0 && log2TbWidth > 4) |
| log2ZoTbWidth = 4 |
| if(tu_mts_idx[x0][y0] > 0 && cIdx == 0 && log2TbHeight > 4) |
| log2ZoTbHeight = 4 |
| log2TbWidth = log2ZoTbWidth |
| log2TbHeight = log2ZoTbHeight |
| ... |

[372] The meanings of the major variables shown in Table 8 are as follows.

[373] 1. cbWidth, cbHeight: the width and height of the current coding block

[374] 2. log2TbWidth, log2TbHeight: the log value of base-2 for the width and height of the current transform block, it may be reduced, by reflecting the zero-out, to a top-left region in which a non-zero coefficient may exist.

[375] 3. sps_lfnst_enabled_flag: a flag indicating whether or not the LFNST is enabled, if the flag value is 0, it indicates that the LFNST is not enabled, and if the flag value is 1, it indicates that the LFNST is enabled. It is defined in the sequence parameter set (SPS).

[376] 4. CuPredMode[chType][x0][y0]: a prediction mode corresponding to the variable chType and the (x0, y0) position, chType may have values of 0 and 1, wherein 0 indicates a luma component and 1 indicates a chroma component. The (x0, y0) position indicates a position on the picture, and MODE_INTRA (intra prediction) and MODE_INTER (inter prediction) are possible as a value of CuPredMode[chType][x0][y0].

[377] 5. IntraSubPartitionsSplit[x0][y0]: the contents of the (x0, y0) position are the same as in No. 4. It indicates which ISP partition at the (x0, y0) position is applied, ISP_NO_SPLIT indicates that the coding unit corresponding to the (x0, y0) position is not divided into partition blocks.

[378] 6. intra_mip_flag[x0][y0]: the contents of the (x0, y0) position are the same as in No. 4 above. The intra_mip_flag is a flag indicating whether or not a matrix-based intra prediction (MIP) prediction mode is applied. If the flag value is 0, it indicates that MIP is not enabled, and if the flag value is 1, it indicates that MIP is enabled.

[379] 7. cIdx: the value of 0 indicates luma, and the values of 1 and 2 indicate Cb and Cr which are respectively chroma components.

[380] 8. treeType: indicates single-tree and dual-tree, etc. (SINGLE_TREE: single tree, DUAL_TREE_LUMA: dual tree for luma component, DUAL_TREE_CHROMA: dual tree for chroma component)

[381] 9. `tu_cbf_cb[x0][y0]`: the contents of the (x0, y0) position are the same as in No. 4. It indicates the coded block flag (CBF) for the Cb component. If its value is 0, it means that no non-zero coefficients are present in the corresponding transform unit for the Cb component, and if its value is 1, it indicates that non-zero coefficients are present in the corresponding transform unit for the Cb component.

[382] 10. `lastSubBlock`: It indicates a position in the scan order of a sub-block (Coefficient Group (CG)) in which the last non-zero coefficient is located. 0 indicates a sub-block in which the DC component is included, and in the case of being greater than 0, it is not a sub-block in which the DC component is included.

[383] 11. `lastScanPos`: It indicates the position where the last significant coefficient is in the scan order within one sub-block. If one sub-block includes 16 positions, values from 0 to 15 are possible.

[384] 12. `lfnst_idx[x0][y0]`: LFNST index syntax element to be parsed. If it is not parsed, it is inferred as a value of 0. That is, the default value is set to 0, indicating that LFNST is not applied.

[385] 13. `LastSignificantCoeffX`, `LastSignificantCoeffY`: They indicate the x and y coordinates where the last significant coefficient is located in the transform block. The x-coordinate starts at 0 and increases from left to right, and the y-coordinate starts at 0 and increases from top to bottom. If the values of both variables are 0, it means that the last significant coefficient is located at DC.

[386] 14. `cu_sbt_flag`: A flag indicating whether or not SubBlock Transform (SBT) included in the current VVC standard is enabled. If a flag value is 0, it indicates that SBT is not enabled, and if the flag value is 1, it indicates that SBT is enabled.

[387] 15. `sps_explicit_mts_inter_enabled_flag`, `sps_explicit_mts_intra_enabled_flag`: Flags indicating whether or not explicit MTS is applied to inter CU and intra CU, respectively. If a

corresponding flag value is 0, it indicates that MTS is not enabled to an inter CU or an intra CU, and if the corresponding flag value is 1, it indicates that MTS is enabled.

[388] 16. tu_mts_idx[x0][y0]: MTS index syntax element to be parsed. If it is not parsed, it is inferred as a value of 0. That is, the default value is set to 0, indicating that DCT-2 is enabled to both the horizontal and vertical directions.

[389] As shown in Table 8, in the case of a single tree, it is possible to determine whether or not to signal the LFNST index using only the last significant coefficient position condition for luma. That is, if the position of the last significant coefficient is not DC and the last significant coefficient exists in the top-left sub-block (CG), for example, a 4x4 block, then the LFNST index is signaled. In this case, in the case of the 4x4 transform block and the 8x8 transform block, the LFNST index is signaled only when the last significant coefficient exists at positions 0 to 7 in the top-left sub-block.

[390] In the case of the dual tree, the LFNST index is signaled independently of each of luma and chroma, and in the case of chroma, the LFNST index can be signaled by applying the last significant coefficient position condition only to the Cb component. The corresponding condition may not be checked for the Cr component, and if the CBF value for Cb is 0, the LFNST index may be signaled by applying the last significant coefficient position condition to the Cr component.

[391] ‘Min(log2TbWidth, log2TbHeight) >= 2’ of Table 8 may be expressed as ‘Min(tbWidth, tbHeight) >= 4’, and ‘Min(log2TbWidth, log2TbHeight) >= 4’ may be expressed as ‘Min(tbWidth, tbHeight) >= 16’.

[392] In Table 8, log2ZoTbWidth and log2ZoTbHeight mean log values whose width and height base are 2 (base-2) for the top-left region where the last significant coefficient may exist by zero-out, respectively.

[393] As shown in Table 8, $\log_2\text{ZoTbWidth}$ and $\log_2\text{ZoTbHeight}$ values may be updated in two places. The first is before the MTS index or LFNST index value is parsed, and the second is after the MTS index is parsed.

[394] The first update is before the MTS index ($\text{tu_mts_idx}[x_0][y_0]$) value is parsed, so $\log_2\text{ZoTbWidth}$ and $\log_2\text{ZoTbHeight}$ can be set regardless of the MTS index value.

[386] After the MTS index is parsed, $\log_2\text{ZoTbWidth}$ and $\log_2\text{ZoTbHeight}$ are set for an MTS index of greater than 0 (DST-7/DCT-8 combination). When DST-7/DCT-8 is independently applied in each of the horizontal and vertical directions in the primary transform, there may be up to 16 significant coefficients per row or column in each direction. That is, after applying DST-7/DCT-8 with a length of 32 or greater, up to 16 transform coefficients may be derived for each row or column from the left or top. Accordingly, in a 2D block, when DST-7/DCT-8 is applied in both the horizontal direction and the vertical direction, significant coefficients may exist in an only up to 16 x 16 top-left region.

[387] In addition, when DCT-2 is independently applied in each of the horizontal and vertical directions in the current primary transform, there may be up to 32 significant coefficients per row or column in each direction. That is, when applying DCT-2 with a length of 64 or greater, up to 32 transform coefficients may be derived for each row or column from the left or top. Accordingly, in a 2D block, when DCT-2 is applied in both the horizontal direction and the vertical direction, significant coefficients may exist in an only up to 32 x 32 top-left region.

[388] In addition, when DST-7/DCT-8 is applied on one side, and DCT-2 is applied on the other side to horizontal and vertical directions, 16 significant coefficients may exist in the former direction, and 32 significant coefficients may exist in the latter direction. For example, in the case of a 64x8 transform block, if DCT-2 is applied in the horizontal direction and DST-7 is applied in the vertical direction (it may occur in a situation where implicit MTS is applied), a significant coefficient may exist in up to a top-left 32x8 region.

[389] If, as shown in Table 8, log2ZoTbWidth and log2ZoTbHeight are updated in two places, that is, before MTS index parsing, the ranges of last_sig_coeff_x_prefix and last_sig_coeff_y_prefix may be determined by log2ZoTbWidth and log2ZoTbHeight as shown in the table below.

[390] [Table 9]

| |
|--|
| <p>7.4.9.11 Residual coding semantics</p> <p>.....</p> <p>last_sig_coeff_x_prefix specifies the prefix of the column position of the last significant coefficient in scanning order within a transform block. The values of last_sig_coeff_x_prefix shall be in the range of 0 to $(\log_2\text{ZoTbWidth} \ll 1) - 1$, inclusive.</p> <p>When last_sig_coeff_x_prefix is not present, it is inferred to be 0.</p> <p>last_sig_coeff_y_prefix specifies the prefix of the row position of the last significant coefficient in scanning order within a transform block. The values of last_sig_coeff_y_prefix shall be in the range of 0 to $(\log_2\text{ZoTbHeight} \ll 1) - 1$, inclusive.</p> <p>When last_sig_coeff_y_prefix is not present, it is inferred to be 0.</p> <p>.....</p> |
|--|

[391] Additionally, in this case, the maximum values of last_sig_coeff_x_prefix and last_sig_coeff_y_prefix may be set by reflecting log2ZoTbWidth and log2ZoTbHeight values in the binarization process for last_sig_coeff_x_prefix and last_sig_coeff_y_prefix.

[392] [Table 10]

| | | | |
|------------------------|-------------------------|-------|--|
| residual coding () | last_sig_coeff_x_prefix | TR | $c_{\text{Max}} = (\log_2\text{ZoTbWidth} \ll 1) - 1$, $c_{\text{RiceParam}} = 0$ |
| | last_sig_coeff_y_prefix | TR | $c_{\text{Max}} = (\log_2\text{ZoTbHeight} \ll 1) - 1$, $c_{\text{RiceParam}} = 0$ |
| | last_sig_coeff_x_suffix | FL | $c_{\text{Max}} = (1 \ll ((\text{last_sig_coeff_x_prefix} \gg 1) - 1) - 1)$ |
| | last_sig_coeff_y_suffix | FL | $c_{\text{Max}} = (1 \ll ((\text{last_sig_coeff_y_prefix} \gg 1) - 1) - 1)$ |
| | | | |

[393] According to an example, in a case where the ISP mode and the LFNST is applied, when signaling of Table 8 is applied, specification text may be configured as shown in Table 11. Compared with Table 8, the condition of signaling the LFNST index only in a case

excluding the ISP mode (`IntraSubPartitionsSplit[x0][y0] == ISP_NO_SPLIT` in Table 8) is deleted.

[394] In a single tree, when an LFNST index transmitted for a luma component (`cIdx = 0`) is reused for a chroma component, an LFNST index transmitted for a first ISP partition block in which a significant coefficient exists may be applied to a chroma transform block. Alternatively, even in a single tree, an LFNST index may be signaled for a chroma component separately from that for a luma component. A description of variables in Table 11 is the same as in Table 8.

[395] [Table 11]

| |
|---|
| residual_coding(x0, y0, log2TbWidth, log2TbHeight, cIdx) { |
| ... |
| if(log2TbWidth > 0) |
| last_sig_coeff_x_prefix |
| if(log2TbHeight > 0) |
| last_sig_coeff_y_prefix |
| if(last_sig_coeff_x_prefix > 3) |
| last_sig_coeff_x_suffix |
| if(last_sig_coeff_y_prefix > 3) |
| last_sig_coeff_y_suffix |
| ... |
| cbWidth = CbWidth[0][x0][y0] |
| cbHeight = CbHeight[0][x0][y0] |
| if(Min(log2TbWidth, log2TbHeight) >= 2 && sps_lfnst_enabled_flag == 1 && CuPredMode[chType][x0][y0] == MODE_INTRA && (!intra_mip_flag[x0][y0] Min(log2TbWidth, log2TbHeight) >= 4) && Max(cbWidth, cbHeight) <= MaxTbSizeY && (cIdx == 0 (treeType == DUAL_TREE_CHROMA && (cIdx == 1 tu_cbf_cb[x0][y0] == 0)))) { |
| if(lastSubBlock == 0 && lastScanPos > 0 && !(lastScanPos > 7 && (log2TbWidth == 2 log2TbWidth == 3) && log2TbWidth == log2TbHeight)) |
| lfnst_idx[x0][y0] |
| } |
| if(cIdx == 0 && lfnst_idx[x0][y0] == 0 && (log2TbWidth <= 5) && (log2TbHeight <= 5) && (LastSignificantCoeffX < 16) && (LastSignificantCoeffY < 16) && (IntraSubPartitionsSplit[x0][y0] == ISP_NO_SPLIT) && (!cu_sbt_flag)) { |
| if(((CuPredMode[chType][x0][y0] == MODE_INTER && sps_explicit_mts_inter_enabled_flag) (CuPredMode[chType][x0][y0] == MODE_INTRA && sps_explicit_mts_intra_enabled_flag))) |
| tu_mts_idx[x0][y0] |
| } |
| } |

[396] According to another example, in Table 11, when the last significant coefficient is allowed to be located only in a DC position for all partition blocks in the ISP, a condition for parsing an LFNST index may be changed as follows.

[397] [Table 12]

| |
|--|
| ... |
| <pre> if(Min(log2TbWidth, log2TbHeight) >= 2 && sps_lfnst_enabled_flag == 1 && CuPredMode[chType][x0][y0] == MODE_INTRA && (!intra_mip_flag[x0][y0] Min(log2TbWidth, log2TbHeight) >= 4) && Max(cbWidth, cbHeight) <= MaxTbSizeY && (cIdx == 0 (treeType == DUAL_TREE_CHROMA && (cIdx == 1 tu_cbf_cb[x0][y0] == 0)))) { </pre> |
| <pre> if(lastSubBlock == 0 && (lastScanPos > 0 IntraSubPartitionsSplit[x0][y0] != ISP_NO_SPLIT) && !(lastScanPos > 7 && (log2TbWidth == 2 log2TbWidth == 3) && log2TbWidth == log2TbHeight) </pre> |
| lfnst_idx[x0][y0] |
| } |
| ... |

[398] According to an example, the LFNST index and/or the MTS index may be signaled in a coding unit level. As described above, the LFNST index may have three values of 0, 1, and 2, where 0 indicates that the LFNST is not applied, and 1 and 2 respectively indicate a first candidate and a second candidate of two LFNST kernel candidates included in a selected LFNST set. The LFNST index is coded through truncated unary binarization, and the values of 0, 1, and 2 may be coded as bin strings of 0, 10, and 11, respectively.

[399] According to an example, the LFNST may be applied only when DCT-2 is applied in both the horizontal direction and the vertical direction in the primary transform. Therefore, if the MTS index is signaled after signaling the LFNST index, the MTS index may be signaled only when the LFNST index is 0, and primary transform may be performed by applying DCT-2 in both the horizontal direction and the vertical direction without signaling the MTS index when the LFNST index is not 0.

[400] The MTS index may have values of 0, 1, 2, 3, and 4, where 0, 1, 2, 3, and 4 may indicate that DCT-2/DCT-2, DST-7/DST-7, DCT-8/DST-7, DST-7/DCT-8, DCT-8/DCT-8 are applied in the horizontal and vertical directions, respectively. In addition, the MTS index may be coded through truncated unitary binarization, and the values of 0, 1, 2, 3, and 4 may be coded as bin strings of 0, 10, 110, 1110, and 1111, respectively.

[401] Signaling the LFNST index in a coding unit level may be indicated as shown in the

following table. The LFNST index may be signaled in the latter part of a coding unit syntax table.

[402] [Table 13]

| | Descriptor |
|---|------------|
| coding_unit(x0, y0, cbWidth, cbHeight, cqtDepth, treeType, modeType) { | |
| | ae(v) |
| if(cu_cbf) { | |
| | |
| LfnstDcOnly = 1 | |
| LfnstZeroOutSigCoeffFlag = 1 | |
| transform_tree(x0, y0, cbWidth, cbHeight, treeType) | |
| lfnstWidth = (treeType == DUAL_TREE_CHROMA) ? cbWidth / SubWidthC : cbWidth | |
| lfnstHeight = (treeType == DUAL_TREE_CHROMA) ? cbHeight / SubHeightC : cbHeight | |
| if(Min(lfnstWidth, lfnstHeight) >= 4 && sps_lfnst_enabled_flag == 1 && CuPredMode[chType][x0][y0] == MODE_INTRA && IntraSubPartitionsSplitType == ISP_NO_SPLIT && (!intra_mip_flag[x0][y0] Min(lfnstWidth, lfnstHeight) >= 16) && tu_mts_idx[x0][y0] == 0 && Max(cbWidth, cbHeight) <= MaxTbSizeY) { | |
| if(LfnstDcOnly == 0 && LfnstZeroOutSigCoeffFlag == 1) | |
| lfnst_idx [x0][y0] | ae(v) |
| } | |
| } | |

[403] A variable LfnstDcOnly and a variable LfnstZeroOutSigCoeffFlag in Table 13 may be set as shown below in Table 16.

[404] The variable LfnstDcOnly is equal to 1 when all last significant coefficients are located at DC positions (top-left positions) for transform blocks having a coded block flag (CBF, equal to 0 if there is at least one significant coefficient in a corresponding block, and is equal to 0 otherwise) of 1, and is equal to 0 otherwise. Specifically, in a case of dual tree luma, the position of the last significant coefficient is checked with respect to one luma transform block, and in a case of dual tree chroma, the position of the last significant coefficient is checked with respect to both a transform block for Cb and a transform block for Cr. In a case of a single tree, the position of the last significant coefficient may be checked with respect to transform block for luma, Cb, and Cr.

[405] The variable LfnstZeroOutSigCoeffFlag is equal to 0 if there is a significant coefficient at a zero-out position when the LFNST is applied, and is equal to 1 otherwise.

[406] `lfnst_idx[x0][y0]` included in Table 13 and subsequent tables indicates an LFNST index for a corresponding coding unit, and `tu_mts_idx[x0][y0]` indicates an MTS index for the corresponding coding unit.

[407] According to an example, to code the MTS index consecutively after the LFNST index in the coding unit level, a coding unit syntax table may be configured as shown in Table 14.

[408] [Table 14]

| coding_unit(x0, y0, cbWidth, cbHeight, cqtDepth, treeType, modeType) { | Descriptor |
|--|------------|
| | ae(v) |
| if(cu_cbf) { | |
| | |
| LfnstDcOnly = 1 | |
| LfnstZeroOutSigCoeffFlag = 1 | |
| transform_tree(x0, y0, cbWidth, cbHeight, treeType) | |
| lfnstWidth = (treeType == DUAL_TREE_CHROMA) ? cbWidth / SubWidthC : cbWidth | |
| lfnstHeight = (treeType == DUAL_TREE_CHROMA) ? cbHeight / SubHeightC : cbHeight | |
| if(Min(lfnstWidth, lfnstHeight) >= 4 && sps_lfnst_enabled_flag == 1 && CuPredMode[chType][x0][y0] == MODE_INTRA && IntraSubPartitionsSplitType == ISP_NO_SPLIT && (!intra_mip_flag[x0][y0] Min(lfnstWidth, lfnstHeight) >= 16) && !transform_skip_flag[x0][y0] && Max(cbWidth, cbHeight) <= MaxTbSizeY) { | |
| if(LfnstDcOnly == 0 && LfnstZeroOutSigCoeffFlag == 1) | |
| lfnst_idx[x0][y0] | ae(v) |
| } | |
| if(tu_cbf_luma[x0][y0] && treeType != DUAL_TREE_CHROMA && lfnst_idx[x0][y0] == 0 && (cbWidth <= 32) && (cbHeight <= 32) && (IntraSubPartitionsSplit[x0][y0] == ISP_NO_SPLIT) && (!cu_sbt_flag)) { | |
| if(((CuPredMode[chType][x0][y0] == MODE_INTER && sps_explicit_mts_inter_enabled_flag) (CuPredMode[chType][x0][y0] == MODE_INTRA && sps_explicit_mts_intra_enabled_flag))) | |
| tu_mts_idx[x0][y0] | ae(v) |
| } | |
| } | |

[409] Comparing Table 14 with Table 13, a condition for checking whether the value of `tu_mts_idx[x0][y0]` is 0 (i.e., checking whether DCT-2 is applied in both the horizontal direction and the vertical direction) in a condition for signaling `lfnst_idx[x0][y0]` is changed to a condition for checking whether the value of `transform_skip_flag[x0][y0]` is 0 (`!transform_skip_flag[x0][y0]`). `transform_skip_flag[x0][y0]` indicates whether the coding unit is coded in the transform skip mode in which a transform is skipped, and the flag is signaled

before the MTS index and the LFNST index. That is, since $\text{lfnst_idx}[x0][y0]$ is signaled before the value of $\text{tu_mtx_idx}[x0][y0]$ is signaled, only the condition for the value of $\text{transform_skip_flag}[x0][y0]$ may be checked.

[410] As shown in Table 14, a plurality of conditions is checked when coding $\text{tu_mts_idx}[x0][y0]$, and $\text{tu_mts_idx}[x0][y0]$ is signaled only when the value of $\text{lfnst_idx}[x0][y0]$ is 0 as described above.

[411] $\text{tu_cbf_luma}[x0][y0]$ is a flag indicating whether a significant coefficient exists for a luma component, and cbWidth and cbHeight indicate the width and height of the coding unit for the luma component, respectively.

[412] In Table 14, $(\text{IntraSubPartitionsSplit}[x0][y0] == \text{ISP_NO_SPLIT})$ indicates that the ISP mode is not applied, and $(!\text{cu_sbt_flag})$ indicates that no SBT is applied.

[413] According to Table 14, when both the width and the height of the coding unit for the luma component are 32 or less, $\text{tu_mts_idx}[x0][y0]$ is signaled, that is, whether an MTS is applied is determined by the width and height of the coding unit for the luma component.

[414] According to another example, when transform block (TU) tiling occurs (e.g., when a maximum transform size is set to 32, a 64 x 64 coding unit is divided into four 32 x 32 transform blocks and coded), the MTS index may be signaled based on the size of each transform block. For example, when both the width and the height of a transform block are 32 or less, the same MTS index value may be applied to all transform blocks in a coding unit, thereby applying the same primary transform. In addition, when transform block tiling occurs, the value of $\text{tu_cbf_luma}[x0][y0]$ in Table 14 may be a CBF value for a top-left transform block, or may be set to 1 when a CBF value for even one transform block of all transform blocks is 1.

[415] According to an example, when the ISP mode is applied to the current block, the LFNST may be applied, in which case Table 14 may be changed as shown in Table 15.

[416] [Table 15]

| | Descript or |
|---|----------------|
| coding_unit(x0, y0, cbWidth, cbHeight, cqtDepth, treeType, modeType) { | |
| | ae(v) |
| if(cu_cbf) { | |
| | |
| LfnstDcOnly = 1 | |
| LfnstZeroOutSigCoeffFlag = 1 | |
| transform_tree(x0, y0, cbWidth, cbHeight, treeType) | |
| lfnstWidth = (treeType == DUAL_TREE_CHROMA) ? cbWidth / SubWidthC : (IntraSubPartitionsSplitType == ISP_VER_SPLIT) ? cbWidth / NumIntraSubPartitions : cbWidth | |
| lfnstHeight = (treeType == DUAL_TREE_CHROMA) ? cbHeight / SubHeightC : (IntraSubPartitionsSplitType == ISP_HOR_SPLIT) ? cbHeight / NumIntraSubPartitions : cbHeight | |
| if(Min(lfnstWidth, lfnstHeight) >= 4 && sps_lfnst_enabled_flag == 1 && CuPredMode[chType][x0][y0] == MODE_INTRA && (!intra_mip_flag[x0][y0] Min(lfnstWidth, lfnstHeight) >= 16) && !transform_skip_flag[x0][y0] && Max(cbWidth, cbHeight) <= MaxTbSizeY) { | |
| if((IntraSubPartitionsSplitType != ISP_NO_SPLIT LfnstDcOnly == 0) && LfnstZeroOutSigCoeffFlag == 1) | |
| lfnst_idx[x0][y0] | ae(v) |
| } | |
| if(tu_cbf_luma[x0][y0] && treeType != DUAL_TREE_CHROMA && lfnst_idx[x0][y0] == 0 && (cbWidth <= 32) && (cbHeight <= 32) && (IntraSubPartitionsSplit[x0][y0] == ISP_NO_SPLIT) && (!cu_sbt_flag)) { | |
| if(((CuPredMode[chType][x0][y0] == MODE_INTER && sps_explicit_mts_inter_enabled_flag) (CuPredMode[chType][x0][y0] == MODE_INTRA && sps_explicit_mts_intra_enabled_flag))) | |
| tu_mts_idx[x0][y0] | ae(v) |
| } | |
| } | |

[417] As shown in Table 15, even in the ISP mode, (IntraSubPartitionsSplitType != ISP_NO_SPLIT) lfnst_idx[x0][y0] may be configured to be signaled, and the same LFNST index value may be applied to all ISP partition blocks.

[418] Further, as shown in Table 15, since tu_mts_idx[x0][y0] may be signaled only in a mode excluding the ISP mode, an MTS index coding part is the same as in Table 14.

[419] As shown in Table 14 and Table 15, when the MTS index is signaled immediately after

the LFNST index, information on the primary transform cannot be known when performing residual coding. That is, the MTS index is signaled after residual coding. Accordingly, in a residual coding part, a part on which a zero-out is performed while leaving only 16 coefficients for DST-7 or DCT-8 having a length of 32 may be changed as shown below in Table 16.

[420] [Table 16]

| residual_coding(x0, y0, log2TbWidth, log2TbHeight, cIdx) { | Descri ptor |
|--|----------------|
| if((sps_mts_enabled_flag && cu_sbt_flag && log2TbWidth < 6 && log2TbHeight < 6) && cIdx == 0 && log2TbWidth > 4) | |
| log2ZoTbWidth = 4 | |
| else | |
| log2ZoTbWidth = Min(log2TbWidth, 5) | |
| MaxCcbs = 2 * (1 << log2TbWidth) * (1 << log2TbHeight) | |
| if((sps_mts_enabled_flag && cu_sbt_flag && log2TbWidth < 6 && log2TbHeight < 6) && cIdx == 0 && log2TbHeight > 4) | |
| log2ZoTbHeight = 4 | |
| else | |
| log2ZoTbHeight = Min(log2TbHeight, 5) | |

[421]

| | |
|---|-------|
| if(log2TbWidth > 0) | |
| last_sig_coeff_x_prefix | ae(v) |
| if(log2TbHeight > 0) | |
| last_sig_coeff_y_prefix | ae(v) |
| if(last_sig_coeff_x_prefix > 3) | |
| last_sig_coeff_x_suffix | ae(v) |
| if(last_sig_coeff_y_prefix > 3) | |
| last_sig_coeff_y_suffix | ae(v) |
| log2TbWidth = log2ZoTbWidth | |
| log2TbHeight = log2ZoTbHeight | |
| remBinsPass1 = ((1 << (log2TbWidth + log2TbHeight)) * 7) >> 2 | |

| | |
|---|--|
| log2SbW = (Min(log2TbWidth, log2TbHeight) < 2 ? 1 : 2) | |
| log2SbH = log2SbW | |
| if(log2TbWidth + log2TbHeight > 3) { | |
| if(log2TbWidth < 2) { | |
| log2SbW = log2TbWidth | |
| log2SbH = 4 - log2SbW | |
| } else if(log2TbHeight < 2) { | |
| log2SbH = log2TbHeight | |
| log2SbW = 4 - log2SbH | |
| } | |
| } | |
| numSbCoeff = 1 << (log2SbW + log2SbH) | |
| lastScanPos = numSbCoeff | |
| lastSubBlock = (1 << (log2TbWidth + log2TbHeight - (log2SbW + log2SbH))) - 1 | |
| do { | |
| if(lastScanPos == 0) { | |
| lastScanPos = numSbCoeff | |
| lastSubBlock-- | |
| } | |
| lastScanPos-- | |
| xS = DiagScanOrder[log2TbWidth - log2SbW][log2TbHeight - log2SbH] [lastSubBlock][0] | |
| yS = DiagScanOrder[log2TbWidth - log2SbW][log2TbHeight - log2SbH] [lastSubBlock][1] | |
| xC = (xS << log2SbW) + DiagScanOrder[log2SbW][log2SbH][lastScanPos][0] | |
| yC = (yS << log2SbH) + DiagScanOrder[log2SbW][log2SbH][lastScanPos][1] | |
| } while((xC != LastSignificantCoeffX) (yC != LastSignificantCoeffY)) | |
| if(lastSubBlock == 0 && log2TbWidth >= 2 && log2TbHeight >= 2 && !transform_skip_flag[x0][y0] && lastScanPos > 0) | |

| | |
|--|--|
| LfstDcOnly= 0 | |
| if((lastSubBlock > 0 && log2TbWidth >= 2 &&log2TbHeight >= 2) (lastScanPos > 7 && (log2TbWidth == 2 log2TbWidth == 3) && log2TbWidth == log2TbHeight)) | |
| LfstZeroOutSigCoeffFlag = 0 | |

[422] As shown in Table 16, in a process of determining $\log_2\text{ZoTbWidth}$ and $\log_2\text{ZoTbHeight}$ (where $\log_2\text{ZoTbWidth}$ and $\log_2\text{ZoTbHeight}$ respectively denote the base-2 log values of the width and height of a top-left region remaining after the zero-out is performed), checking the value of $\text{tu_mts_idx}[x0][y0]$ may be omitted.

[423] Binarization of $\text{last_sig_coeff_x_prefix}$ and $\text{last_sig_coeff_y_prefix}$ in Table 16 may be determined based on $\log_2\text{ZoTbWidth}$ and $\log_2\text{ZoTbHeight}$ as shown in Table 10.

[424] Further, as shown in Table 16, a condition of checking $\text{sps_mts_enable_flag}$ may be added when determining $\log_2\text{ZoTbWidth}$ and $\log_2\text{ZoTbHeight}$ in residual coding.

[425] TR in Table 10 indicates a truncated Rice binarization method, and last significant coefficient information may be binarized based on cMax and cRiceParam defined in Table 10 according to a method described in the following table.

[426] [Table 17]

9.3.3.3 Truncated Rice binarization process

Input to this process is a request for a truncated Rice (TR) binarization, $cMax$ and $cRiceParam$.

Output of this process is the TR binarization associating each value $symbolVal$ with a corresponding bin string.

A TR bin string is a concatenation of a prefix bin string and, when present, a suffix bin string.

For the derivation of the prefix bin string, the following applies:

–The prefix value of $symbolVal$, $prefixVal$, is derived as follows:

$$prefixVal = symbolVal \gg cRiceParam \tag{9-11}$$

–The prefix of the TR bin string is specified as follows:

–If $prefixVal$ is less than $cMax \gg cRiceParam$, the prefix bin string is a bit string of length $prefixVal + 1$ indexed by $binIdx$. The bins for $binIdx$ less than $prefixVal$ are equal to 1. The bin with $binIdx$ equal to $prefixVal$ is equal to 0. Table 9-79 illustrates the bin strings of this unary binarization for $prefixVal$.

–Otherwise, the bin string is a bit string of length $cMax \gg cRiceParam$ with all bins being equal to 1.

Table 9-79 – Bin string of the unary binarization (informative)

| prefixVal | Bin string | | | | | |
|------------------|-------------------|----------|----------|----------|----------|----------|
| 0 | 0 | | | | | |
| 1 | 1 | 0 | | | | |
| 2 | 1 | 1 | 0 | | | |
| 3 | 1 | 1 | 1 | 0 | | |
| 4 | 1 | 1 | 1 | 1 | 0 | |
| 5 | 1 | 1 | 1 | 1 | 1 | 0 |
| ... | | | | | | |
| binIdx | 0 | 1 | 2 | 3 | 4 | 5 |

When $cMax$ is greater than $symbolVal$ and $cRiceParam$ is greater than 0, the suffix of the TR bin string is present and it is derived as follows:

–The suffix value $suffixVal$ is derived as follows:

$$suffixVal = symbolVal - ((prefixVal) \ll cRiceParam) \tag{9-12}$$

–The suffix of the TR bin string is specified by invoking the fixed-length (FL) binarization process as specified in clause 9.3.3.7 for suffixVal with a cMax value equal to $(1 \ll cRiceParam) - 1$.

NOTE – For the input parameter cRiceParam = 0, the TR binarization is exactly a truncated unary binarization and it is always invoked with a cMax value equal to the largest possible value of the syntax element being decoded.

[427] In another example, a coding unit syntax table and a residual coding syntax table are as follows.

[428] [Table 18]

| |
|---|
| <code>coding_unit(x0, y0, cbWidth, cbHeight, cqtDepth, treeType, modeType) {</code> |
| <code>...</code> |
| <code> LfstDcOnly = 1</code> |
| <code> LfstZeroOutSigCoeffFlag = 1</code> |
| <code> MtsZeroOutSigCoeffFlag = 1</code> |
| <code> transform_tree(x0, y0, cbWidth, cbHeight, treeType)</code> |
| <code> lfstWidth = (treeType == DUAL_TREE_CHROMA) ? cbWidth / SubWidthC</code> <code> : (IntraSubPartitionsSplitType == ISP_VER_SPLIT) ?</code> <code> cbWidth / NumIntraSubPartitions : cbWidth</code> |
| <code> lfstHeight = (treeType == DUAL_TREE_CHROMA) ? cbHeight / SubHeightC</code> <code> : (IntraSubPartitionsSplitType == ISP_HOR_SPLIT) ?</code> <code> cbHeight / NumIntraSubPartitions : cbHeight</code> |
| <code> if(Min(lfstWidth, lfstHeight) >= 4 && sps_lfst_enabled_flag == 1 &&</code> <code> CuPredMode[chType][x0][y0] == MODE_INTRA &&</code> <code> (!intra_mip_flag[x0][y0] Min(lfstWidth, lfstHeight) >= 16) &&</code> <code> Max(cbWidth, cbHeight) <= MaxTbSizeY) {</code> |
| <code> if((IntraSubPartitionsSplitType != ISP_NO_SPLIT LfstDcOnly == 0) &&</code> <code> LfstZeroOutSigCoeffFlag == 1)</code> |
| <code> lfst_idx[x0][y0]</code> |
| <code> }</code> |
| <code> if(treeType != DUAL_TREE_CHROMA && lfst_idx[x0][y0] == 0 &&</code> <code> transform_skip_flag[x0][y0] == 0 && Max(cbWidth, cbHeight) <= 32 &&</code> <code> IntraSubPartitionsSplit[x0][y0] == ISP_NO_SPLIT && (!cu_sbt_flag) &&</code> <code> MtsZeroOutSigCoeffFlag == 1) {</code> |
| <code> if(((CuPredMode[chType][x0][y0] == MODE_INTER &&</code> <code> sps_explicit_mts_inter_enabled_flag)</code> <code> (CuPredMode[chType][x0][y0] == MODE_INTRA &&</code> <code> sps_explicit_mts_intra_enabled_flag)))</code> |
| <code> mts_idx[x0][y0]</code> |
| <code> }</code> |
| <code> ...</code> |

[429] [Table 19]

| |
|--|
| <code>residual_coding(x0, y0, log2TbWidth, log2TbHeight, cIdx) {</code> |
| <code>...</code> |
| <code>if ((cu_sbt_flag && log2TbWidth < 6 && log2TbHeight < 6)</code> |
| <code> && cIdx == 0 && log2TbWidth > 4)</code> |
| <code> log2ZoTbWidth = 4</code> |
| <code>else</code> |
| <code> log2ZoTbWidth = Min(log2TbWidth, 5)</code> |
| <code> MaxCcbcs = 2 * (1 << log2TbWidth) * (1 << log2TbHeight)</code> |
| <code>if ((cu_sbt_flag && log2TbWidth < 6 && log2TbHeight < 6)</code> |
| <code> && cIdx == 0 && log2TbHeight > 4)</code> |
| <code> log2ZoTbHeight = 4</code> |
| <code>else</code> |
| <code> log2ZoTbHeight = Min(log2TbHeight, 5)</code> |
| <code>...</code> |
| <code>if((lastSubBlock > 0 && log2TbWidth >= 2 && log2TbHeight >= 2) </code> |
| <code> (lastScanPos > 7 && (log2TbWidth == 2 log2TbWidth == 3) &&</code> |
| <code> log2TbWidth == log2TbHeight)</code> |
| <code> LfnstZeroOutSigCoeffFlag = 0</code> |
| <code>if((LastSignificantCoeffX > 15 LastSignificantCoeffY > 15) && cIdx == 0)</code> |
| <code> MtsZeroOutSigCoeffFlag = 0</code> |
| <code>...</code> |

[430] In Table 18, MtsZeroOutSigCoeffFlag is initially set to 1, and this value may be changed in residual coding in Table 19. The value of a variable MtsZeroOutSigCoeffFlag is changed from 1 to 0 when a significant coefficient exists in a region (LastSignificantCoeffX > 15 || LastSignificantCoeffY > 15) to be filled with 0s by a zero-out, in which case the MTS index is not signaled as shown in Table 19.

[431] According to an example, an MTS index coding part in Table 18 may be changed as shown in the following table.

[432] [Table 20]

| |
|---|
| <code>coding_unit(x0, y0, cbWidth, cbHeight, cqtDepth, treeType, modeType) {</code> |
| <code>...</code> |
| <code> LfnstDcOnly = 1</code> |
| <code> LfnstZeroOutSigCoeffFlag = 1</code> |
| <code> MtsZeroOutSigCoeffFlag = 0</code> |

| |
|--|
| transform_tree(x0, y0, cbWidth, cbHeight, treeType) |
| lfnstWidth = (treeType == DUAL_TREE_CHROMA) ? cbWidth / SubWidthC : (IntraSubPartitionsSplitType == ISP_VER_SPLIT) ? cbWidth / NumIntraSubPartitions : cbWidth |
| lfnstHeight = (treeType == DUAL_TREE_CHROMA) ? cbHeight / SubHeightC : (IntraSubPartitionsSplitType == ISP_HOR_SPLIT) ? cbHeight / NumIntraSubPartitions : cbHeight |
| if(Min(lfnstWidth, lfnstHeight) >= 4 && sps_lfnst_enabled_flag == 1 && CuPredMode[chType][x0][y0] == MODE_INTRA && (!intra_mip_flag[x0][y0] Min(lfnstWidth, lfnstHeight) >= 16) && Max(cbWidth, cbHeight) <= MaxTbSizeY) { |
| if((IntraSubPartitionsSplitType != ISP_NO_SPLIT LfnstDcOnly == 0) && LfnstZeroOutSigCoeffFlag == 1) |
| lfnst_idx [x0][y0] |
| } |
| if(treeType != DUAL_TREE_CHROMA && lfnst_idx[x0][y0] == 0 && transform_skip_flag[x0][y0] == 0 && Max(cbWidth, cbHeight) <= 32 && IntraSubPartitionsSplit[x0][y0] == ISP_NO_SPLIT && (!cu_sbt_flag) && MtsZeroOutSigCoeffFlag == 1) { |
| if(((CuPredMode[chType][x0][y0] == MODE_INTER && sps_explicit_mts_inter_enabled_flag) (CuPredMode[chType][x0][y0] == MODE_INTRA && sps_explicit_mts_intra_enabled_flag))) |
| mts_idx [x0][y0] |
| } |
| ... |

[433] Unlike in Table 18, a variable MtsZeroOutSigCoeffFlag in Table 20 is initialized to 0 rather than 1 (MtsZeroOutSigCoeffFlag = 0). The value of the variable MtsZeroOutSigCoeffFlag is maintained as 0 when a significant coefficient exists in a region (LastSignificantCoeffX > 15 || LastSignificantCoeffY > 15) to be filled with 0s by a zero-out, in which case the MTS index is not signaled.

[434] The following drawings were prepared to explain a specific example of the present specification. Since the names of specific devices described in the drawings or the names of specific signals/messages/fields are presented by way of example, the technical features of the present specification are not limited to the specific names used in the following drawings.

[435] FIG. 19 is a flowchart showing operation of a video decoding apparatus according to an embodiment of the present document.

[436] Each step disclosed in FIG. 19 is based on some of the contents described above in FIGS. 2 to 18. Therefore, an explanation for the specific content duplicated with contents described above in FIGS. 2 to 18 will be omitted or made briefly.

[437] According to an embodiment, the decoding apparatus 200 may perform residual coding based on residual information received from a bitstream, and specifically may parse the residual information received in a residual coding level and may arrange transform coefficients for a current block according to a predetermined scan order (S1910).

[438] The decoding apparatus 200 may decode information on quantized transform coefficients for the current block from the bitstream, and may derive the quantized transform coefficients for the target block based on the information on the quantized transform coefficients for the current block. The information on the quantized transform coefficients for the target block may be incorporated in a sequence parameter set (SPS) or a slice header, and may include at least one of information on whether or not the reduced transform (RST) is applied, information on the reduced factor, information on a minimum transform size to which the reduced transform is applied, information on a maximum transform size to which the reduced transform is applied, and information on the transform index indicating any one of the simplified inverse transform size and transform kernel matrix included in the transform set.

[439] In addition, the decoding apparatus may further receive information on the intra prediction mode for the current block and information on whether or not the ISP is applied to the current block. The decoding apparatus may derive whether or not the current block is

divided into a predetermined number of sub-partition transform blocks by receiving and parsing flag information indicating whether or not to apply ISP coding or ISP mode. Here, the current block may be a coding block. Additionally, the decoding apparatus may derive the size and number of divided sub-partition blocks through flag information indicating in which direction the current block will be divided.

[440] The decoding apparatus 200 may derive the transform coefficients by dequantizing the residual information on the current block, that is, the quantized transform coefficients, and may arrange the derived transform coefficients according to the predetermined scan order.

[441] More specifically, the derived transform coefficients may be arranged according to the reverse diagonal scan order in units of 4×4 blocks, and transform coefficients within the 4×4 block may also be arranged according to the reverse diagonal scan order. That is, transform coefficients on which dequantization has been performed may be arranged according to a reverse scan order applied in a video codec such as in VVC or HEVC.

[442] A transform coefficient derived based on this residual information may be a dequantized transform coefficient as described above, and may also be a quantized transform coefficient. That is, the transform coefficient may be any data capable of checking whether or not it is non-zero data in the current block regardless of whether or not it is quantized.

[443] The decoding apparatus may derive residual samples by applying an inverse transform to the quantized transform coefficients.

[444] As described above, the decoding apparatus may derive residual samples by applying LFNST, which is a non-separable transform, or MTS, which is a separable transform, and such transforms may be performed based on the LFNST index indicating the LFNST kernel, that is, the LFNST matrix, and the MTS index indicating the MTS kernel, respectively.

[445] The decoding apparatus may receive and parse at least one of the LFNST index or the MTS index in a coding unit level, and may parse the LFNST index indicating the LFNST kernel before, that is, immediately before, the MTS index indicating the MTS kernel (S1920).

[446] The MTS index may be parsed according to a specific condition for the LFNST index, for example, when the LFNST index is 0.

[447] The residual coding level may include syntax for last significant coefficient position information, and the LFNST index may be parsed after the last significant coefficient position information is parsed.

[448] According to an example, when the current block is a luma block and the LFNST index is 0, the MTS index may be parsed. That is, when the current block is a luma block, and if the LFNST index is greater than 0, the MTS index may not be parsed.

[449] According to an example, when the tree type of the current block is a dual tree, the LFNST index for each of the luma block and the chroma block may be parsed.

[450] Meanwhile, in the deriving the transform coefficient, the width and height for the top-left region in which the last significant coefficient may exist in the current block by zero-out may be derived, and the width and height for the top-left region may be derived before parsing the MTS index.

[451] Meanwhile, the position of the last significant coefficient may be derived by the width and height for the top-left region, and the last significant coefficient position information may be binarized based on the width and height for the top-left region.

[452] Alternatively, according to an example, when the tree type of the current block is a single-tree type, the decoding apparatus may perform residual coding on the luma block and the chroma block of the current block and may then parse the LFNST index.

[453] When the LFNST index is parsed in the coding unit level after performing the residual coding not in a transform block level or the residual coding level, the LFNST index reflecting the positions of complete transform coefficients for the luma block and the chroma block and zero-out information entailed in the transform process rather than transform coefficient information on either the luma block or the chroma block may be received.

[454] When the tree type of the current block is a dual-tree type and the chroma component

is coded, the decoding apparatus may perform residual coding on a Cb component and a Cr component of the chroma block and may then parse the LFNST index.

[455] When the LFNST index is parsed in the coding unit level after performing the residual coding not in the transform block level or the residual coding level, the LFNST index reflecting the positions of complete transform coefficients for the Cb component and the Cr component of the chroma block and zero-out information entailed in the transform process rather than transform coefficient information on any one of the Cb component and the Cr component of the chroma block may be received.

[456] When the current block is partitioned into a plurality of sub-partition blocks, the decoding apparatus may perform residual coding on the plurality of sub-partition blocks and may then parse the LFNST index.

[457] Similarly to the above description, when the LFNST index is parsed in the coding unit level after performing the residual coding not in the transform block level or the residual coding level, the LFNST index reflecting the positions of complete transform coefficients for all sub-partition blocks and zero-out information entailed in the transform process rather than transform coefficient information on some or individual sub-partition blocks may be received.

[458] According to an example, when the current block is partitioned into the plurality of sub-partition blocks, the LFNST index may be parsed regardless of whether a transform coefficient exists in a region excluding a DC position of each of the plurality of sub-partition blocks. That is, if the last significant coefficient is allowed to be located only in the DC position for all sub-partition blocks when ISP is applied to the current block, signaling of the LFNST index may be allowed.

[459] In a residual coding process, the decoding apparatus may derive a first variable indicating whether a transform coefficient exists in a region excluding a DC position of the current block, and may derive a second variable indicating whether a transform coefficient exists in a second region excluding a top-left first region of the current block or a sub-partition

block into which the current block is partitioned.

[460] The decoding apparatus may parse the LFNST index when a transform coefficient exists in the region excluding the DC position and a transform coefficient does not exist in the second region.

[461] Specifically, in order to determine whether to parse the LFNST index, the decoding apparatus may derive the first variable indicating whether the transform coefficient, that is, a significant coefficient, exists in the region excluding the DC position of the current block.

[462] The first variable may be a variable `LfnstDcOnly` that can be derived in the residual coding process. The first variable may be derived as 0 when the index of a subblock including the last significant coefficient in the current block is 0 and the position of the last significant coefficient in the subblock is greater than 0, and the LFNST index may be parsed when the first variable is 0. A subblock refers to a 4 x 4 block used as a coding unit in residual coding and may also be referred to as a coefficient group (CG). A subblock index of 0 indicates a top-left 4 x 4 subblock.

[463] The first variable may be initially set to 1, and may be maintained as 1 or may be changed to 0 depending on whether a significant coefficient exists in the region excluding the DC position.

[464] The variable `LfnstDcOnly` indicates whether a non-zero coefficient exists at a non-DC component position for at least one transform block within one coding unit, may be 0 when a non-zero coefficient exists at a non-DC component position for at least one transform block within one coding unit, and may be 1 when a non-zero coefficient does not exist at a non-DC component position for all transform blocks within one coding unit.

[465] The decoding apparatus may derive the second variable indicating whether a significant coefficient exists in the second region excluding the top-left first region of the current block, thereby checking whether a zero-out has been performed on the second area.

[466] The second variable may be a variable `LfnstZeroOutSigCoeffFlag` that may indicate

that a zero-out is performed when the LFNST is applied. The second variable may be initially set to 1, and may be changed to 0 when a significant coefficient exists in the second region.

[467] The variable `LfnstZeroOutSigCoeffFlag` may be derived as 0 when the index of a subblock in which the last non-zero coefficient exists is greater than 0 and both the width and the height of a transform block is equal to or greater than 4 or when the position of the last-non-zero coefficient in the subblock in which the last non-zero coefficient exists is greater than 7 and the size of the transform block is 4 x 4 or 8 x 8. A subblock refers to a 4 x 4 block used as a coding unit in residual coding and may also be referred to as a coefficient group (CG). A subblock index of 0 indicates a top-left 4 x 4 subblock.

[468] That is, when a non-zero coefficient is derived in a region excluding the top-left region where an LFNST transform coefficient can exist in the transform block, or a non-zero coefficient exists outside an eighth position in a scan order for the 4 x 4 block and the 8 x 8 block, the variable `LfnstZeroOutSigCoeffFlag` is set to 0.

[469] According to an example, when ISP is applied to the coding unit, if it is identified that a transform coefficient exists in a position excluding a position where the LFNST transform coefficient can exist even for one sub-partition block among all sub-partition blocks, signaling the LFNST index may be omitted. That is, when a zero-out is not performed in one sub-partition block and a significant coefficient exists in the second region, the LFNST index is not signaled.

[470] The first region may be derived based on the size of the current block.

[471] For example, when the size of the current block is 4 x 4 or 8 x 8, the first region may be from the top left of the current block to an eighth sample position in a scan direction. When the current block is partitioned and the size of a sub-partition block is 4 x 4 or 8 x 8, the first region may be from the top left of the sub-partition block to an eighth sample position in the scan direction.

[472] When the size of the current block is 4 x 4 or 8 x 8, eight pieces of data are output through a forward LFNST, and thus eighth transform coefficients received by the decoding

apparatus may be arranged from the top left of the current block to the eighth sample position in the scan direction as shown in (a) of FIG. 11 and (a) of FIG. 12.

[473] When the size of the current block is not 4 x 4 or 8 x 8, the first region may be a top-left 4 x 4 region of the current block. When the size of the current block is not 4 x 4 or 8 x 8, 16 pieces of data are output through the forward LFNST, and thus 16 transform coefficients received by the decoding apparatus may be arranged in a top-left 4 x 4 region of the current block as shown in (b) to (d) of FIG. 11 and (b) of FIG. 12.

[474] Transform coefficients that may be arranged in the first region may be arranged according to a diagonal scan direction as shown in FIG. 7.

[475] As described above, when the current block is partitioned into the sub-partition blocks, if no transform coefficient exists in all individual second regions for the plurality of sub-partition blocks, the decoding apparatus may parse the LFNST index. When a transform coefficient exists in the second region for any one sub-partition block, the LFNST index is not parsed.

[476] As described above, the LFNST may be applied to a sub-partition block having a width and a height of 4 or greater, and the LFNST index for the current block that is the coding block may be applied to the plurality of sub-partition blocks.

[477] Since the LFNST-reflected zero-out (including all zero-outs entailed in applying the LFNST) is applied to the sub-partition block as it is, the first region is equally applied to the sub-partition block. That is, when the partitioned sub-partition block is a 4 x 4 block or an 8 x 8 block, the LFNST may be applied from the top left of the sub-partition block to an eighth transform coefficient in the scan direction, and when the sub-partition block is not a 4 x 4 block or an 8 x 8 block, the LFNST may be applied to transform coefficients in a top-left 4 x 4 region of the sub-partition block.

[478] In addition, in the residual coding process, the decoding apparatus may derive a third variable indicating whether a transform coefficient exists in a region excluding a top-left 16 x

16 region of the current block, and may parse the MTS index when no transform coefficient exists in the region excluding the 16 x 16 region.

[479] The third variable may be a variable `MtsZeroOutSigCoeffFlag` that may indicate that a zero-out is performed when an MTS is applied. The variable `MtsZeroOutSigCoeffFlag` indicates whether a transform coefficient exists in a top-left region where the last significant coefficient can exist by the zero-out after performing the MTS, that is, the region excluding the top-left 16 x 16 region, and the value of the third variable may be initially set to 1 and may be changed from 1 to 0 when a transform coefficient exists in the region excluding the top-left 16 x 16 region. When the value of the third variable is 0, the MTS index is not signaled.

[480] The decoding apparatus may derive residual samples by applying at least one of the LFNST performed based on the LFNST index or the MTS performed based on the MTS index (S1930).

[481] Subsequently, the decoding apparatus 200 may generate reconstructed samples based on the residual samples for the current block and prediction samples for the current block (S1940).

[482] The following drawings were prepared to explain a specific example of the present specification. Since the names of specific devices described in the drawings or the names of specific signals/messages/fields are presented by way of example, the technical features of the present specification are not limited to the specific names used in the following drawings.

[483] FIG. 20 is a flowchart showing operation of a video encoding apparatus according to an embodiment of the present document.

[484] Each step disclosed in FIG. 20 is based on some of the contents described above in FIGS. 3 to 18. Therefore, an explanation for the specific content duplicated with contents described above in FIGS. 1, and 3 to 18 will be omitted or made briefly.

[485] The encoding apparatus 100 according to an embodiment may derive the prediction sample for the current block based on the intra prediction mode applied to the current block (S2010).

[486] The encoding apparatus may perform prediction for each sub-partition transform block in the case where the ISP is applied to the current block.

[487] The encoding apparatus may determine whether or not to apply the ISP coding or ISP mode to the current block, that is, the coding block, and according to the determination result, it is possible to determine in which direction the current block is to be divided, and to derive the size and number of sub-blocks to be divided.

[488] The encoding apparatus 100 may derive residual samples for the current block based on the prediction samples (S2020).

[489] The encoding apparatus 100 may derive transform coefficients for the current block by applying at least one of an LFNST or an MTS to the residual samples and may arrange the transform coefficients according to a predetermined scan order (S2030).

[490] The primary transform may be performed through a plurality of transform kernels such as MTS, and in this case, the transform kernel may be selected based on the intra prediction mode.

[491] Also, the encoding apparatus 100 may determine whether or not to perform secondary transform, or non-separable transform, specifically LFNST, on transform coefficients for the current block, and may apply LFNST to transform coefficients to derive modified transform coefficients.

[492] The LFNST is a non-separable transform that applies the transform without separating the coefficients in a specific direction, unlike the primary transform that separates and transforms in a vertical or horizontal direction, coefficients which are transform targets. Such non-separable transform may be a low-frequency non-separable transform that applies

transform only to a low-frequency region rather than the entire target block which is a transform target.

[493] When the ISP is applied to the current block, the encoding apparatus may determine whether or not the LFNST can be applied to the height and width of the divided sub-partition block.

[494] The encoding apparatus may determine whether or not the LFNST can be applied to the height and width of the divided sub-partition block. In this case, the decoding apparatus may parse the LFNST index when the height and width of the sub-partition block are equal to or greater than 4.

[495] The encoding apparatus may encode at least one of the LFNST index indicating the LFNST kernel and the MTS index indicating the MTS kernel (S2040).

[496] The MTS index may be encoded according to a specific condition for the LFNST index, for example, when the LFNST index is 0.

[497] According to an example, when the current block is a luma block and the LFNST index indicates 0, the encoding apparatus may encode the MTS index.

[498] According to an example, when the tree type of the current block is a dual tree, the encoding apparatus may encode the LFNST index for each of the luma block and the chroma block.

[499] According to an example, when the transform coefficient is derived, the encoding apparatus may derive the width and height for the top-left region in which the last significant coefficient may exist in the current block by zero-out may derive the last significant coefficient position based on the width and height for the top-left region, and may binarize the last significant coefficient position information.

[500] According to an example, the width and height for the top-left region may be derived before signaling of the MTS index.

[501] Alternatively, according to an example, when the tree type of the current block is a

single-tree type, the encoding apparatus may derive all transform coefficients for the luma block and the chroma block of the current block and may then encode the LFNST index in a coding unit level.

[502] When the LFNST index is encoded in the coding unit level after deriving all of the transform coefficients not in a transform block level or the residual coding level, the LFNST index reflecting the positions of complete transform coefficients for the luma block and the chroma block and zero-out information entailed in the transform process rather than transform coefficient information on either the luma block or the chroma block may be encoded.

[503] When the tree type of the current block is a dual-tree type and the chroma component is coded, the encoding apparatus may derive all transform coefficients a Cb component and a Cr component of the chroma block and may then encode the LFNST index in the coding unit level.

[504] When the LFNST index is encoded in the coding unit level after deriving all of the transform coefficients not in the transform block level or the residual coding level, the LFNST index reflecting the positions of complete transform coefficients for the Cb component and the Cr component of the chroma block and zero-out information entailed in the transform process rather than transform coefficient information on any one of the Cb component and the Cr component of the chroma block may be encoded.

[505] When the current block is partitioned into a plurality of sub-partition blocks, the encoding apparatus may derive all of the transform coefficients for the plurality of sub-partition blocks and may then encode the LFNST index in the coding unit level.

[506] Similarly to the above description, when the LFNST index is parsed in the coding unit level after deriving all of the transform coefficients not in the transform block level or the residual coding level, the LFNST index reflecting the positions of complete transform coefficients for all sub-partition blocks and zero-out information entailed in the transform process rather than transform coefficient information on some or individual sub-partition

blocks may be encoded.

[507] When the current block is partitioned into the plurality of sub-partition blocks, the encoding apparatus may encode the LFNST index regardless of whether a transform coefficient exists in a region excluding a DC position of each of the plurality of sub-partition blocks. That is, if the last significant coefficient is allowed to be located only in the DC position for all sub-partition blocks when ISP is applied to the current block, signaling of the LFNST index may be allowed.

[508] In a process of deriving the transform coefficients, the encoding apparatus may derive a first variable indicating whether a transform coefficient exists in a region excluding a DC position of the current block and a second variable indicating whether a transform coefficient exists in a second region excluding a top-left first region of the current block or a sub-partition block into which the current block is partitioned.

[509] The encoding apparatus may encode the LFNST index when a transform coefficient exists in the region excluding the DC position and a transform coefficient does not exist in the second region.

[510] Specifically, the first variable may be a variable `LfnstDcOnly` and may be derived as 0 when the index of a subblock including the last significant coefficient in the current block is 0 and the position of the last significant coefficient in the subblock is greater than 0, and the LFNST index may be encoded when the first variable is 0.

[511] The first variable may be initially set to 1, and may be maintained as 1 or may be changed to 0 depending on whether a significant coefficient exists in the region excluding the DC position.

[512] The variable `LfnstDcOnly` indicates whether a non-zero coefficient exists at a non-DC component position for at least one transform block within one coding unit, may be 0 when a non-zero coefficient exists at a non-DC component position for at least one transform block within one coding unit, and may be 1 when a non-zero coefficient does not exist at a non-DC

component position for all transform blocks within one coding unit.

[513] The encoding apparatus may zero-out the second region of the current block where no modified transform coefficients exist after performing the LFNST, and may derive the second variable indicating whether the transform coefficient exists in the second region.

[514] As shown in FIG. 11 and FIG. 12, the remaining region of the current block where no modified transform coefficients exist may be zeroed-out. Due to this zero-out, it is possible to reduce the amount of computation required to perform the entire transform process and to reduce the amount of operation required for the entire transform process, thus reducing power consumption required to perform the transform. Further, latency entailed in the transform process may be reduced, thus increasing image coding efficiency.

[515] The second variable may be a variable `LfnstZeroOutSigCoeffFlag` that may indicate that a zero-out is performed when the LFNST is applied. The second variable may be initially set to 1, and may be changed to 0 when a significant coefficient exists in the second region.

[516] The variable `LfnstZeroOutSigCoeffFlag` may be derived as 0 when the index of a subblock in which the last non-zero coefficient exists is greater than 0 and both the width and the height of a transform block is equal to or greater than 4 or when the position of the last-non-zero coefficient in the subblock in which the last non-zero coefficient exists is greater than 7 and the size of the transform block is 4 x 4 or 8 x 8.

[517] That is, when a non-zero coefficient is derived in a region excluding the top-left region where an LFNST transform coefficient can exist in the transform block, or a non-zero coefficient exists outside an eighth position in a scan order for the 4 x 4 block and the 8 x 8 block, the variable `LfnstZeroOutSigCoeffFlag` is set to 0.

[518] A description of the first region and a description of the zero-out in a case where the ISP is applied are substantially the same as those described in the decoding method, and thus a redundant description will be omitted.

[519] According to an example, the encoding apparatus may perform the zero-out when the

MTS is applied in a primary transform of the current block. The encoding apparatus may perform the zero-out of filling a region excluding a top-left 16 x 16 region of the current block or the sub-partition block with 0s and may encode the MTS index according to a third variable indicating whether a transform coefficient exists in a zero-out region.

[520] The third variable may be a variable `MtsZeroOutSigCoeffFlag` that may indicate that a zero-out is performed when an MTS is applied. The variable `MtsZeroOutSigCoeffFlag` indicates whether a transform coefficient exists in a top-left region where the last significant coefficient can exist by the zero-out after performing the MTS, that is, the region excluding the top-left 16 x 16 region, and the value of the third variable may be initially set to 1 and may be changed from 1 to 0 when a transform coefficient exists in the region excluding the top-left 16 x 16 region. When the value of the third variable is 0, the MTS index is not encoded and signaled.

[521] The encoding apparatus may construct and output image information so that at least one of the LFNST index and the MTS index is signaled in the coding unit level and the MTS index is signaled immediately after the LFNST index is signaled (S2050).

[522] Additionally, the encoding apparatus may derive the quantized transform coefficients by performing quantization based on the transform coefficient or modified transform coefficients for the current block, and may encode and output image information including information on the quantized transform coefficients.

[523] The encoding apparatus may generate residual information including information on quantized transform coefficients. The residual information may include the above-described transform related information/syntax element. The encoding apparatus may encode image/video information including the residual information, and may output the encoded image/video information in the form of a bitstream.

[524] More specifically, the encoding apparatus may generate information on the quantized transform coefficients, and may encode information on the generated quantized transform coefficients.

[525] In the present disclosure, at least one of quantization/dequantization and/or transform/inverse transform may be omitted. When quantization/dequantization is omitted, a quantized transform coefficient may be referred to as a transform coefficient. When transform/inverse transform is omitted, the transform coefficient may be referred to as a coefficient or a residual coefficient, or may still be referred to as a transform coefficient for consistency of expression.

[526] In addition, in the present disclosure, a quantized transform coefficient and a transform coefficient may be referred to as a transform coefficient and a scaled transform coefficient, respectively. In this case, residual information may include information on a transform coefficient(s), and the information on the transform coefficient(s) may be signaled through a residual coding syntax. Transform coefficients may be derived based on the residual information (or information on the transform coefficient(s)), and scaled transform coefficients may be derived through inverse transform (scaling) of the transform coefficients. Residual samples may be derived based on the inverse transform (transform) of the scaled transform coefficients. These details may also be applied/expressed in other parts of the present disclosure.

[527] In the above-described embodiments, the methods are explained on the basis of flowcharts by means of a series of steps or blocks, but the present disclosure is not limited to the order of steps, and a certain step may be performed in order or step different from that described above, or concurrently with another step. Further, it may be understood by a person having ordinary skill in the art that the steps shown in a flowchart are not exclusive, and that another step may be incorporated or one or more steps of the flowchart may be removed without affecting the scope of the present disclosure.

[528] The above-described methods according to the present disclosure may be implemented as a software form, and an encoding apparatus and/or decoding apparatus according to the disclosure may be included in a device for image processing, such as, a TV, a computer, a smartphone, a set-top box, a display device or the like.

[529] When embodiments in the present disclosure are embodied by software, the above-described methods may be embodied as modules (processes, functions or the like) to perform the above-described functions. The modules may be stored in a memory and may be executed by a processor. The memory may be inside or outside the processor and may be connected to the processor in various well-known manners. The processor may include an application-specific integrated circuit (ASIC), other chipset, logic circuit, and/or a data processing device. The memory may include a read-only memory (ROM), a random access memory (RAM), a flash memory, a memory card, a storage medium, and/or other storage device. That is, embodiments described in the present disclosure may be embodied and performed on a processor, a microprocessor, a controller or a chip. For example, function units shown in each drawing may be embodied and performed on a computer, a processor, a microprocessor, a controller or a chip.

[530] Further, the decoding apparatus and the encoding apparatus to which the present disclosure is applied, may be included in a multimedia broadcasting transceiver, a mobile communication terminal, a home cinema video device, a digital cinema video device, a surveillance camera, a video chat device, a real time communication device such as video communication, a mobile streaming device, a storage medium, a camcorder, a video on demand (VoD) service providing device, an over the top (OTT) video device, an Internet streaming service providing device, a three-dimensional (3D) video device, a video telephony video device, and a medical video device, and may be used to process a video signal or a data signal. For example, the over the top (OTT) video device may include a game console, a Blu-ray player,

an Internet access TV, a Home theater system, a smartphone, a Tablet PC, a digital video recorder (DVR) and the like.

[531] In addition, the processing method to which the present disclosure is applied, may be produced in the form of a program executed by a computer, and be stored in a computer-readable recording medium. Multimedia data having a data structure according to the present disclosure may also be stored in a computer-readable recording medium. The computer-readable recording medium includes all kinds of storage devices and distributed storage devices in which computer-readable data are stored. The computer-readable recording medium may include, for example, a Blu-ray Disc (BD), a universal serial bus (USB), a ROM, a PROM, an EPROM, an EEPROM, a RAM, a CD-ROM, a magnetic tape, a floppy disk, and an optical data storage device. Further, the computer-readable recording medium includes media embodied in the form of a carrier wave (for example, transmission over the Internet). In addition, a bitstream generated by the encoding method may be stored in a computer-readable recording medium or transmitted through a wired or wireless communication network. Additionally, the embodiments of the present disclosure may be embodied as a computer program product by program codes, and the program codes may be executed on a computer by the embodiments of the present disclosure. The program codes may be stored on a computer-readable carrier.

[532] FIG. 21 schematically illustrates an example of a video/image coding system to which the present disclosure is applicable.

[533] Referring to FIG. 21, the video/image coding system may include a first device (source device) and a second device (receive device). The source device may deliver encoded video/image information or data in the form of a file or streaming to the receive device via a digital storage medium or network.

[534] The source device may include a video source, an encoding apparatus, and a transmitter. The receive device may include a receiver, a decoding apparatus, and a renderer.

The encoding apparatus may be called a video/image encoding apparatus, and the decoding apparatus may be called a video/image decoding apparatus. The transmitter may be included in the encoding apparatus. The receiver may be included in the decoding apparatus. The renderer may include a display, and the display may be configured as a separate device or an external component.

[535] The video source may obtain a video/image through a process of capturing, synthesizing, or generating a video/image. The video source may include a video/image capture device and/or a video/image generating device. The video/image capture device may include, for example, one or more cameras, video/image archives including previously captured video/images, or the like. The video/image generating device may include, for example, a computer, a tablet and a smartphone, and may (electronically) generate a video/image. For example, a virtual video/image may be generated through a computer or the like. In this case, the video/image capturing process may be replaced by a process of generating related data.

[536] The encoding apparatus may encode an input video/image. The encoding apparatus may perform a series of procedures such as prediction, transform, and quantization for compression and coding efficiency. The encoded data (encoded video/image information) may be output in the form of a bitstream.

[537] The transmitter may transmit the encoded video/image information or data output in the form of a bitstream to the receiver of the receive device through a digital storage medium or a network in the form of a file or streaming. The digital storage medium may include various storage mediums such as USB, SD, CD, DVD, Blu-ray, HDD, SSD, and the like. The transmitter may include an element for generating a media file through a predetermined file format, and may include an element for transmission through a broadcast/communication network. The receiver may receive/extract the bitstream and transmit the received/extracted bitstream to the decoding apparatus.

[538] The decoding apparatus may decode a video/image by performing a series of procedures such as dequantization, inverse transform, prediction, and the like corresponding to the operation of the encoding apparatus.

[539] The renderer may render the decoded video/image. The rendered video/image may be displayed through the display.

[540] FIG. 22 illustrates the structure of a content streaming system to which the present disclosure is applied.

[541] Further, the contents streaming system to which the present disclosure is applied may largely include an encoding server, a streaming server, a web server, a media storage, a user equipment, and a multimedia input device.

[542] The encoding server functions to compress to digital data the contents input from the multimedia input devices, such as the smart phone, the camera, the camcoder and the like, to generate a bitstream, and to transmit it to the streaming server. As another example, in a case where the multimedia input device, such as, the smart phone, the camera, the camcoder or the like, directly generates a bitstream, the encoding server may be omitted. The bitstream may be generated by an encoding method or a bitstream generation method to which the present disclosure is applied. And the streaming server may store the bitstream temporarily during a process to transmit or receive the bitstream.

[543] The streaming server transmits multimedia data to the user equipment on the basis of a user's request through the web server, which functions as an instrument that informs a user of what service there is. When the user requests a service which the user wants, the web server transfers the request to the streaming server, and the streaming server transmits multimedia data to the user. In this regard, the contents streaming system may include a separate control server, and in this case, the control server functions to control commands/responses between respective equipments in the content streaming system.

[544] The streaming server may receive contents from the media storage and/or the encoding server. For example, in a case the contents are received from the encoding server, the contents may be received in real time. In this case, the streaming server may store the bitstream for a predetermined period of time to provide the streaming service smoothly.

[545] For example, the user equipment may include a mobile phone, a smart phone, a laptop computer, a digital broadcasting terminal, a personal digital assistant (PDA), a portable multimedia player (PMP), a navigation, a slate PC, a tablet PC, an ultrabook, a wearable device (e.g., a watch-type terminal (smart watch), a glass-type terminal (smart glass), a head mounted display (HMD)), a digital TV, a desktop computer, a digital signage or the like. Each of servers in the contents streaming system may be operated as a distributed server, and in this case, data received by each server may be processed in distributed manner.

[546] Claims disclosed herein can be combined in a various way. For example, technical features of method claims of the present disclosure can be combined to be implemented or performed in an apparatus, and technical features of apparatus claims can be combined to be implemented or performed in a method. Further, technical features of method claims and apparatus claims can be combined to be implemented or performed in an apparatus, and technical features of method claims and apparatus claims can be combined to be implemented or performed in a method.

[547] The effects that can be obtained through specific examples of the present disclosure are not limited to the effects listed above. For example, there may be various technical effects that a person having ordinary skill in the related art can understand or derive from the present disclosure. Accordingly, specific effects of the present disclosure are not limited to those explicitly described in the present disclosure and may include various effects that can be understood or derived from the technical features of the present disclosure.

[548] Although embodiments have been described with reference to a number of illustrative embodiments thereof, it will be understood by those skilled in the art that various changes in

form and details may be made therein without departing from the spirit and scope of the invention as defined by the appended claims. Many modifications will be apparent to those skilled in the art without departing from the scope of the present invention as herein described with reference to the accompanying drawings.

CLAIMS:

1. An image decoding method performed by a decoding apparatus, the method comprising:

performing residual coding of arranging transform coefficients for a current block according to a predetermined scan order by parsing residual information received in a residual coding level;

deriving residual samples by applying at least one of an LFNST or an MTS to the transform coefficients; and

generating a reconstructed picture based on the residual samples,

wherein the LFNST is performed based on an LFNST index indicating an LFNST kernel,

wherein the MTS is performed based on an MTS index indicating an MTS kernel,

wherein the LFNST index and the MTS index are signaled in a coding unit level, and

wherein the MTS index is signaled immediately after the LFNST index is signaled.

2. The image decoding method of claim 1, wherein, when a tree type of the current block is a single-tree type, the LFNST index is parsed after the residual coding for a luma block and a chroma block of the current block is performed.

3. The image decoding method of claim 1, wherein, when a tree type of the current block is a dual-tree type and a chroma component is coded, the LFNST index is parsed after the residual coding for a Cb component and a Cr component of the chroma block is performed.

4. The image decoding method of claim 1, wherein, when the current block is partitioned into a plurality of sub-partition blocks, the LFNST index is parsed after the residual coding for the plurality of sub-partition blocks is performed.

5. The image decoding method of claim 4, wherein, when the current block is partitioned into the plurality of sub-partition blocks, the LFNST index is parsed regardless of whether the transform coefficients exist in a region excluding a DC position of each of the plurality of sub-partition blocks.

6. The image decoding method of claim 1, wherein the steps of performing the residual coding comprises:

deriving a first variable indicating whether the transform coefficients exist in a region excluding a DC position of the current block; and

deriving a second variable indicating whether the transform coefficients exist in a second region excluding a top-left first region of the current block or the sub-partition blocks into which the current block is partitioned, and

wherein the LFNST index is parsed when the transform coefficients exist in the region excluding the DC position and the transform coefficients do not exist in the second region.

7. The image decoding method of claim 1, wherein the steps of performing the residual coding comprises deriving a third variable indicating whether the transform coefficients exist in a region excluding a top-left 16 x 16 region of the current block, and

wherein the MTS index is parsed when the transform coefficients do not exist in the region excluding the 16 x 16 region.

8. An image encoding method performed by an encoding apparatus, the method comprising:

deriving prediction samples for a current block;

deriving residual samples for the current block based on the prediction samples;

performing a transform coefficient derivation operation of deriving transform coefficients for the current block by applying at least one of an LFNST or an MTS to the residual samples and arranging the transform coefficients according to a predetermined scan order;

encoding at least one of an LFNST index indicating an LFNST kernel or an MTS index indicating an MTS kernel; and

constructing and outputting image information so that the LFNST index and the MTS index are signaled in a coding unit level and the MTS index is signaled immediately after the LFNST index is signaled.

9. The image encoding method of claim 8, wherein, when a tree type of the current block is a single-tree type, the LFNST index is encoded after the transform coefficient derivation operation for a luma block and a chroma block of the current block is performed.

10. The image encoding method of claim 8, wherein, when a tree type of the current block is a dual-tree type and a chroma component is coded, the LFNST index is encoded after the transform coefficient derivation operation for a Cb component and a Cr component of the chroma block is performed.

11. The image encoding method of claim 8, wherein, when the current block is partitioned into a plurality of sub-partition blocks, the LFNST index is encoded after the transform coefficient derivation operation for the plurality of sub-partition blocks is performed.

12. The image encoding method of claim 11, wherein, when the current block is partitioned into the plurality of sub-partition blocks, the LFNST index is encoded regardless of whether the transform coefficients exist in a region excluding a DC position of each of the sub-partition blocks.

13. The image encoding method of claim 8, wherein the step of performing the transform coefficient derivation operation comprises:

deriving a first variable indicating whether the transform coefficients exist in a region excluding a DC position of the current block; and

deriving a second variable indicating whether the transform coefficients exist in a second region excluding a top-left first region of the current block or the sub-partition blocks into which the current block is partitioned, and

wherein the LFNST index is encoded when the transform coefficients exist in the region excluding the DC position and the transform coefficients do not exist in the second region.

14. The image encoding method of claim 8, wherein the performing of the transform coefficient derivation operation comprises deriving a third variable indicating whether the transform coefficients exist in a region excluding a top-left 16 x 16 region of the current block, and

wherein the MTS index is encoded when the transform coefficients do not exist in the region excluding the 16 x 16 region.

15. A computer-readable digital storage medium that stores indication information to cause an image decoding method to be performed, the decoding method comprising:

performing residual coding of arranging transform coefficients for a current block according to a predetermined scan order by parsing residual information received in a residual coding level;

deriving residual samples by applying at least one of an LFNST or an MTS to the transform coefficients; and

generating a reconstructed picture based on the residual samples,

wherein the LFNST is performed based on an LFNST index indicating an LFNST kernel,

wherein the MTS is performed based on an MTS index indicating an MTS kernel,

wherein the LFNST index and the MTS index are signaled in a coding unit level, and

wherein the MTS index is signaled immediately after the LFNST index is signaled.

FIG. 1

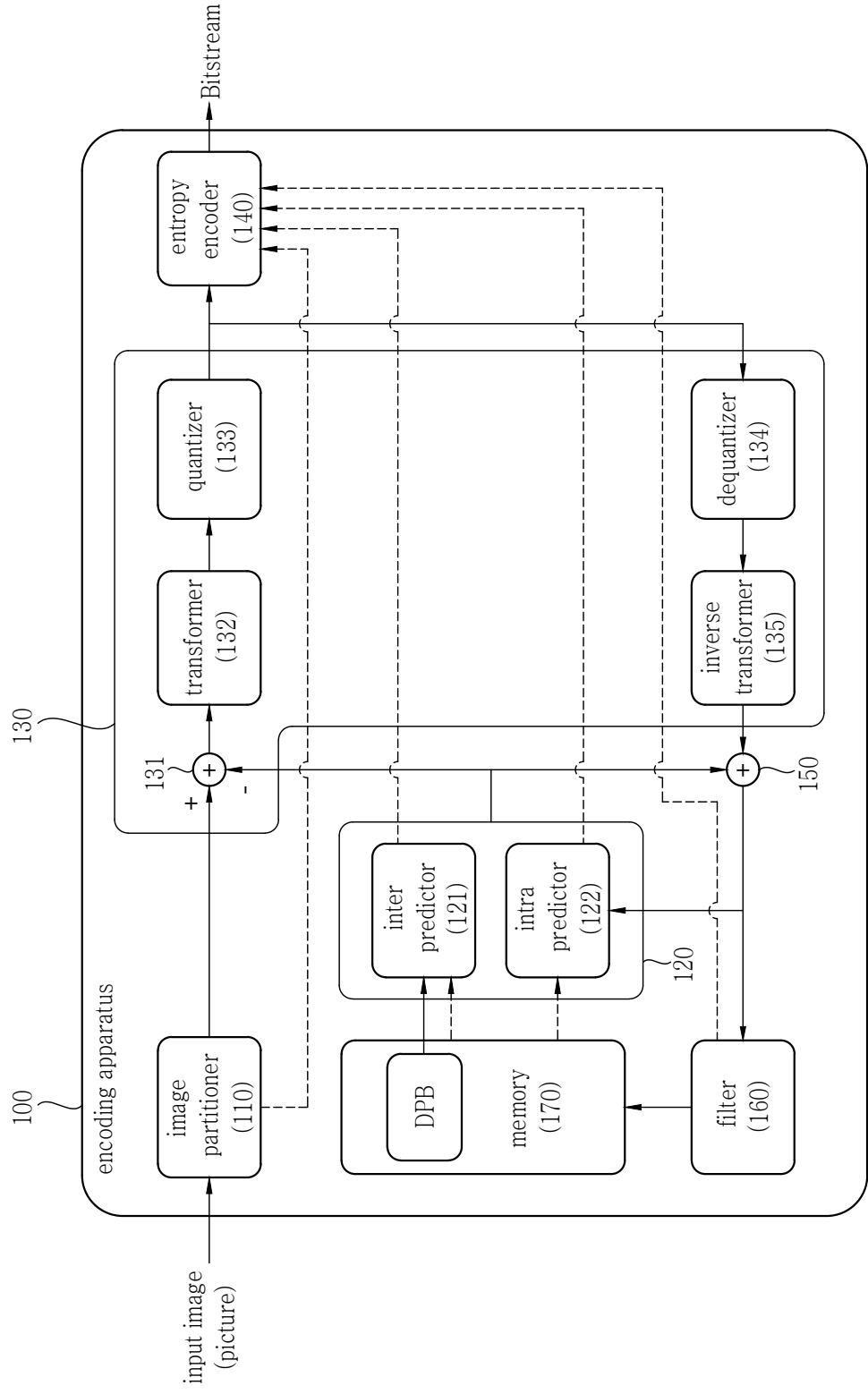

FIG. 2

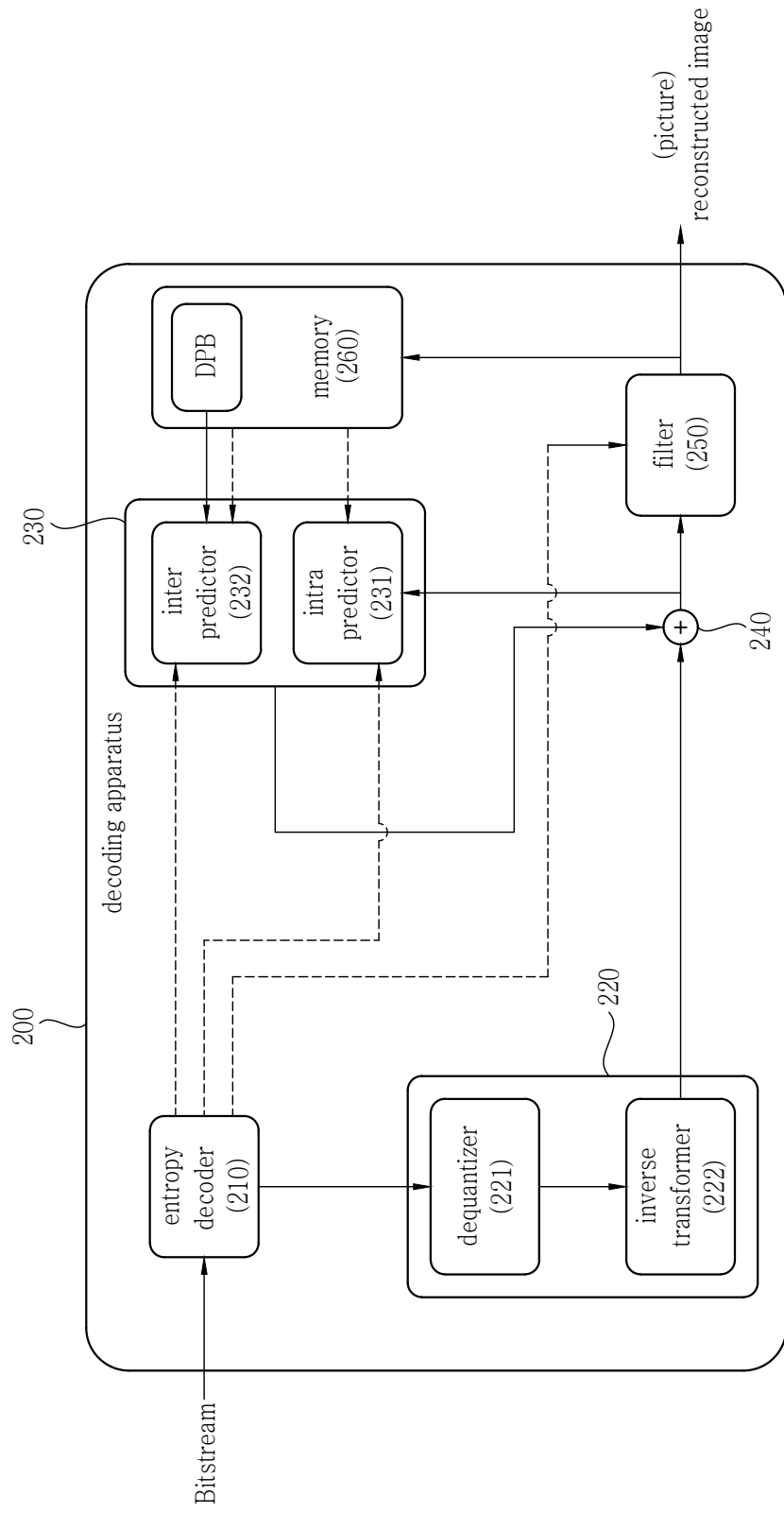

FIG. 3

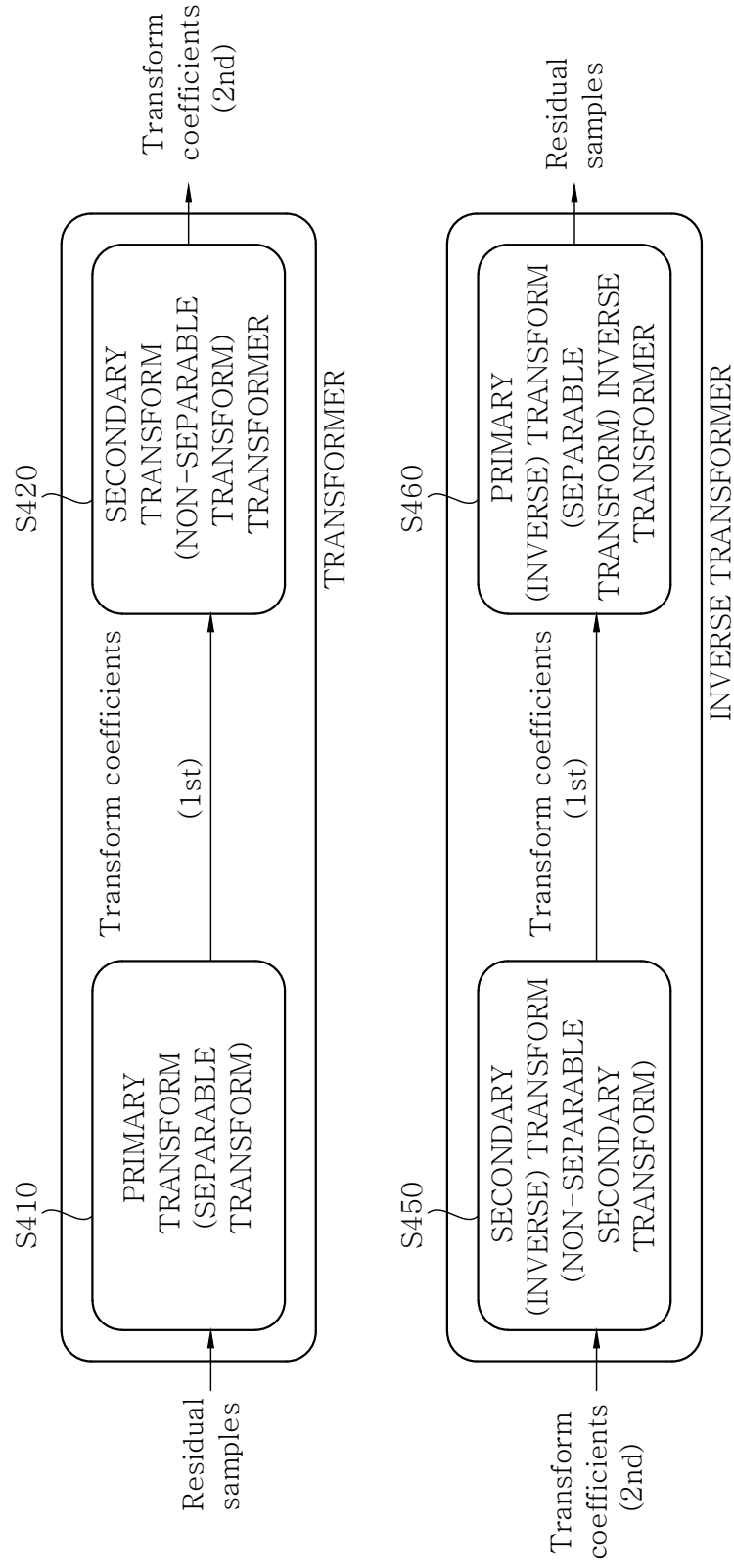

FIG. 4

11 Mar 2026

2026201822

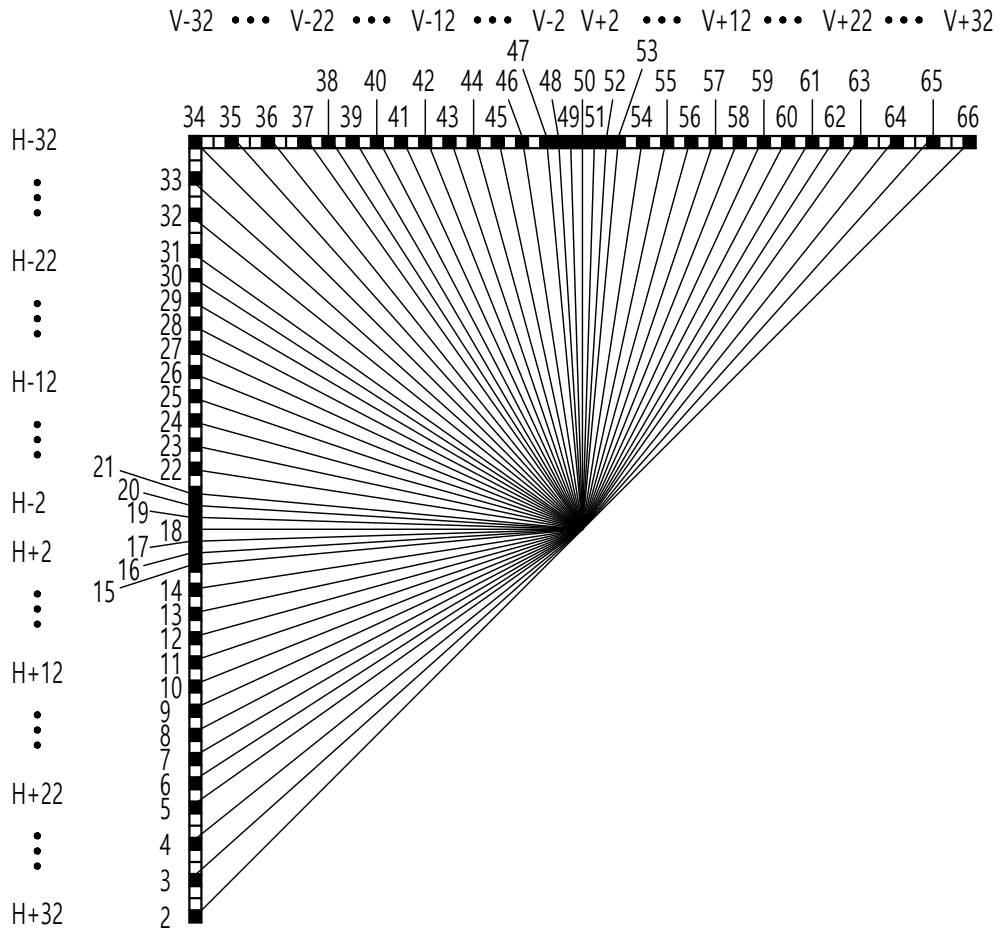

FIG. 5

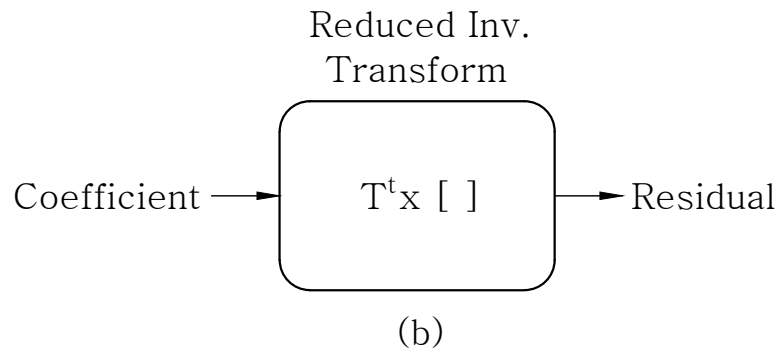
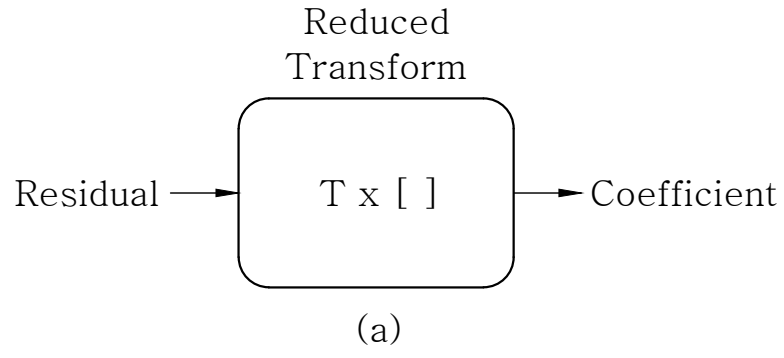

FIG. 6

2026201822 11 Mar 2026

| | | | | | | | |
|----|----|----|----|----|----|----|----|
| 1 | 2 | 3 | 4 | 5 | 6 | 7 | 8 |
| 9 | 10 | 11 | 12 | 13 | 14 | 15 | 16 |
| 17 | 18 | 19 | 20 | 21 | 22 | 23 | 24 |
| 25 | 26 | 27 | 28 | 29 | 30 | 31 | 32 |
| 33 | 34 | 35 | 36 | | | | |
| 37 | 38 | 39 | 40 | | | | |
| 41 | 42 | 43 | 44 | | | | |
| 45 | 46 | 47 | 48 | | | | |

| | | | |
|----|----|----|----|
| 1 | 2 | 3 | 4 |
| 5 | 6 | 7 | 8 |
| 9 | 10 | 11 | 12 |
| 13 | 14 | 15 | 16 |

(a)

| | | | | | | | |
|---|----|----|----|----|----|----|----|
| 1 | 9 | 17 | 25 | 33 | 37 | 41 | 45 |
| 2 | 10 | 18 | 26 | 34 | 38 | 42 | 46 |
| 3 | 11 | 19 | 27 | 35 | 39 | 43 | 47 |
| 4 | 12 | 20 | 28 | 36 | 40 | 44 | 48 |
| 5 | 13 | 21 | 29 | | | | |
| 6 | 14 | 22 | 30 | | | | |
| 7 | 15 | 23 | 31 | | | | |
| 8 | 16 | 24 | 32 | | | | |









| | | | |
|---|---|----|----|
| 1 | 5 | 9 | 13 |
| 2 | 6 | 10 | 14 |
| 3 | 7 | 11 | 15 |
| 4 | 8 | 12 | 16 |

(b)

FIG. 7

| | | | |
|---|----|----|----|
| 1 | 3 | 6 | 10 |
| 2 | 5 | 9 | 13 |
| 4 | 8 | 12 | 15 |
| 7 | 11 | 14 | 16 |

(a)

| | | | |
|---|---|---|---|
| 1 | 3 | 6 |  |
| 2 | 5 |  |  |
| 4 | 8 |  |  |
| 7 |  |  |  |

(b)

FIG. 8

(a) 4×4 (b) $8 \times 4 / 4 \times 8$ (c) $4 \times N / N \times 4$, when $N \geq 16$ (d) 8×8 (e) $M \times N (M \geq 8, N \geq 8, M > 8 \text{ or } N > 8)$

FIG. 9



(a) 4x4

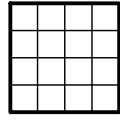
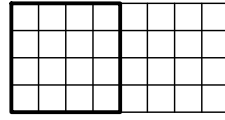
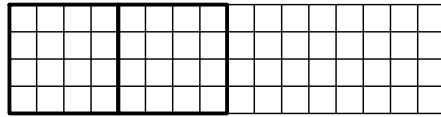
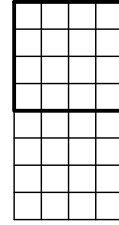
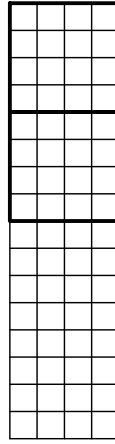
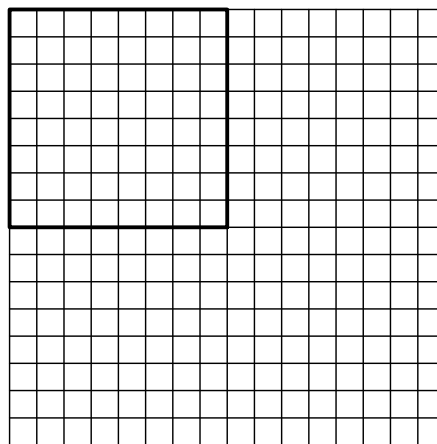
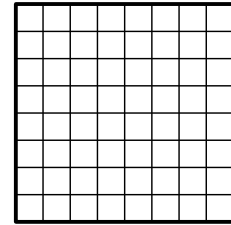
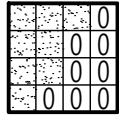
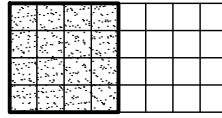

(b) 8x4 / 4x8

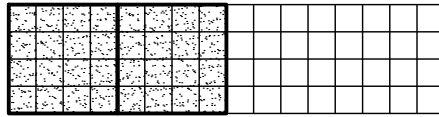

(c) 4xN / Nx4, when $N \geq 16$

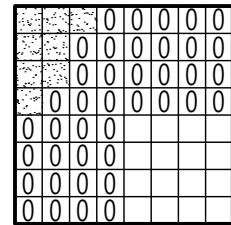
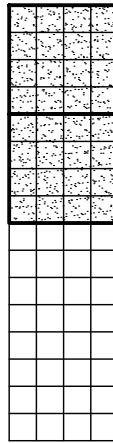

(d) 8x8

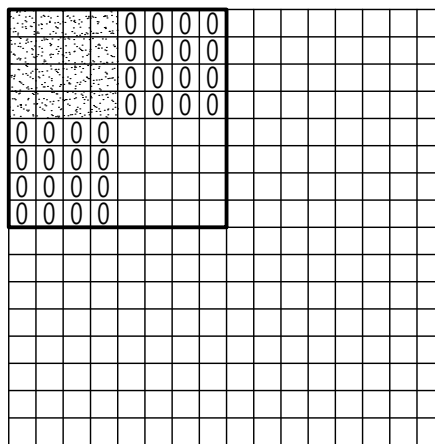

(e) $M \times N (M \geq 8, N \geq 8, M > 8 \text{ or } N > 8)$

FIG. 10

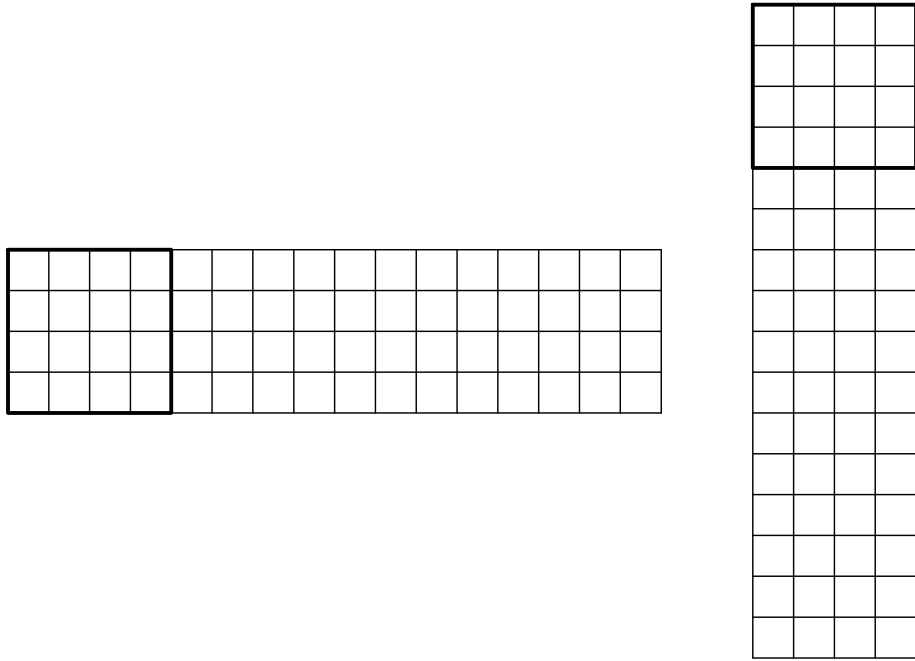

$4 \times N / N \times 4$, when $N \geq 16$

FIG. 13

| | | | | | | | | | | | | | | | | |
|---|---|---|---|---|---|---|---|---|---|---|---|---|---|---|---|---|
| | | | | 0 | 0 | 0 | 0 | 0 | 0 | 0 | 0 | 0 | 0 | 0 | 0 | 0 |
| | | | | 0 | 0 | 0 | 0 | 0 | 0 | 0 | 0 | 0 | 0 | 0 | 0 | 0 |
| | | | | 0 | 0 | 0 | 0 | 0 | 0 | 0 | 0 | 0 | 0 | 0 | 0 | 0 |
| | | | | 0 | 0 | 0 | 0 | 0 | 0 | 0 | 0 | 0 | 0 | 0 | 0 | 0 |
| 0 | 0 | 0 | 0 | | | | | 0 | 0 | 0 | 0 | 0 | 0 | 0 | 0 | 0 |
| 0 | 0 | 0 | 0 | | | | | 0 | 0 | 0 | 0 | 0 | 0 | 0 | 0 | 0 |
| 0 | 0 | 0 | 0 | | | | | 0 | 0 | 0 | 0 | 0 | 0 | 0 | 0 | 0 |
| 0 | 0 | 0 | 0 | | | | | 0 | 0 | 0 | 0 | 0 | 0 | 0 | 0 | 0 |
| 0 | 0 | 0 | 0 | 0 | 0 | 0 | 0 | 0 | 0 | 0 | 0 | 0 | 0 | 0 | 0 | 0 |
| 0 | 0 | 0 | 0 | 0 | 0 | 0 | 0 | 0 | 0 | 0 | 0 | 0 | 0 | 0 | 0 | 0 |
| 0 | 0 | 0 | 0 | 0 | 0 | 0 | 0 | 0 | 0 | 0 | 0 | 0 | 0 | 0 | 0 | 0 |
| 0 | 0 | 0 | 0 | 0 | 0 | 0 | 0 | 0 | 0 | 0 | 0 | 0 | 0 | 0 | 0 | 0 |
| 0 | 0 | 0 | 0 | 0 | 0 | 0 | 0 | 0 | 0 | 0 | 0 | 0 | 0 | 0 | 0 | 0 |
| 0 | 0 | 0 | 0 | 0 | 0 | 0 | 0 | 0 | 0 | 0 | 0 | 0 | 0 | 0 | 0 | 0 |
| 0 | 0 | 0 | 0 | 0 | 0 | 0 | 0 | 0 | 0 | 0 | 0 | 0 | 0 | 0 | 0 | 0 |
| 0 | 0 | 0 | 0 | 0 | 0 | 0 | 0 | 0 | 0 | 0 | 0 | 0 | 0 | 0 | 0 | 0 |

FIG. 14

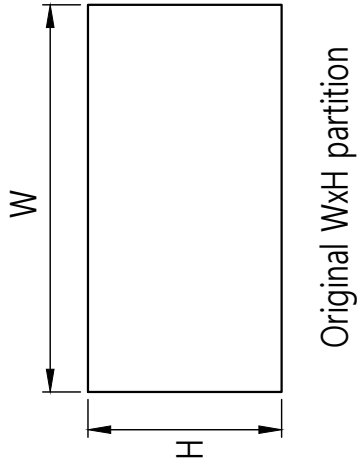
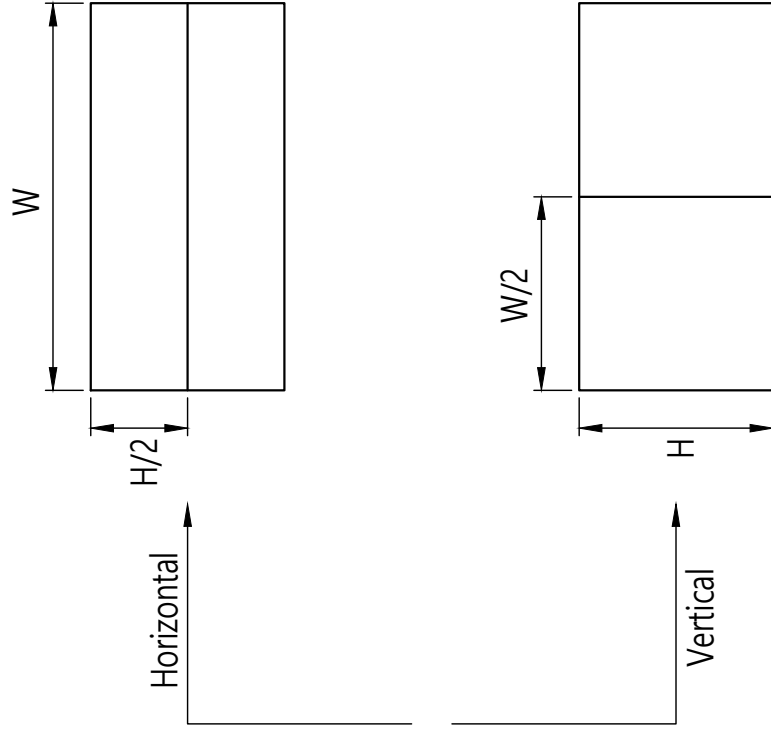

FIG. 15

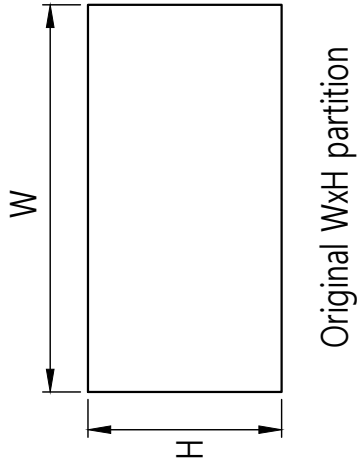
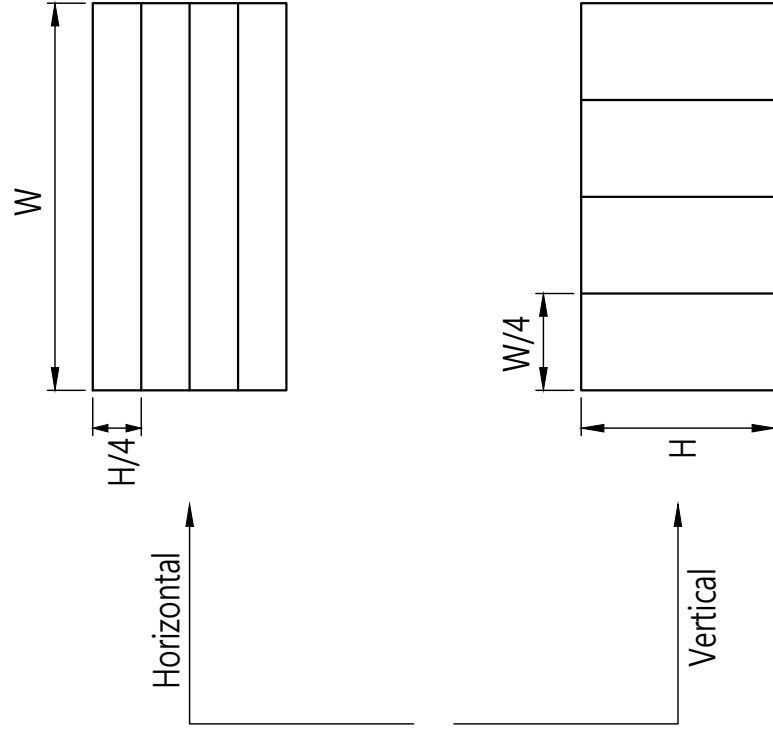

FIG. 16

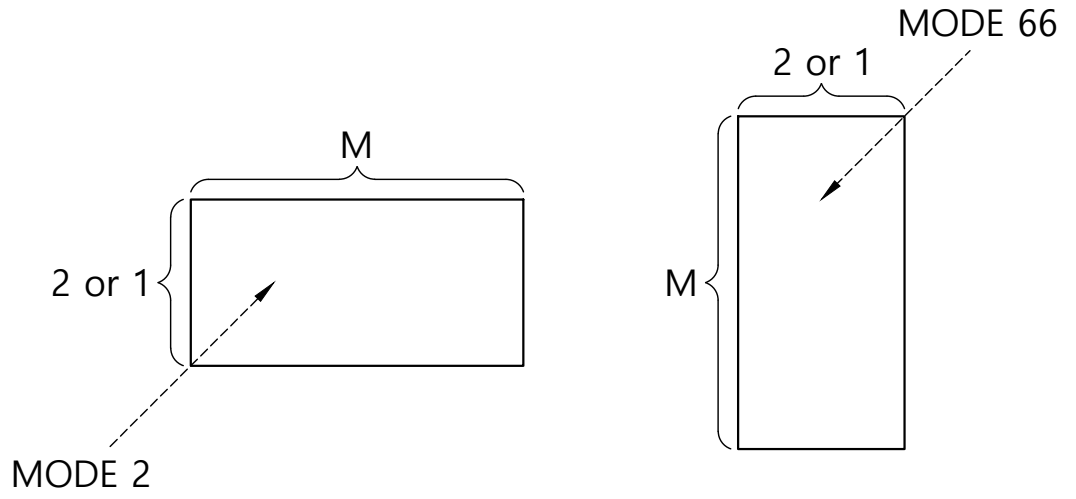

FIG. 17

| | |
|---|----|
| 1 | 9 |
| 2 | 10 |
| 3 | 11 |
| 4 | 12 |
| 5 | 13 |
| 6 | 14 |
| 7 | 15 |
| 8 | 16 |

(a)

| | | | | | | | |
|---|----|----|----|----|----|----|----|
| 1 | 2 | 3 | 4 | 5 | 6 | 7 | 8 |
| 9 | 10 | 11 | 12 | 13 | 14 | 15 | 16 |

(b)

FIG. 18

| | | | | | | | |
|---|---|---|---|----|----|----|----|
| 1 | 3 | 5 | 7 | 9 | 11 | 13 | 15 |
| 2 | 4 | 6 | 8 | 10 | 12 | 14 | 16 |

| | |
|----|----|
| 1 | 3 |
| 2 | 5 |
| 4 | 7 |
| 6 | 9 |
| 8 | 11 |
| 10 | 13 |
| 12 | 15 |
| 14 | 16 |

FIG. 19

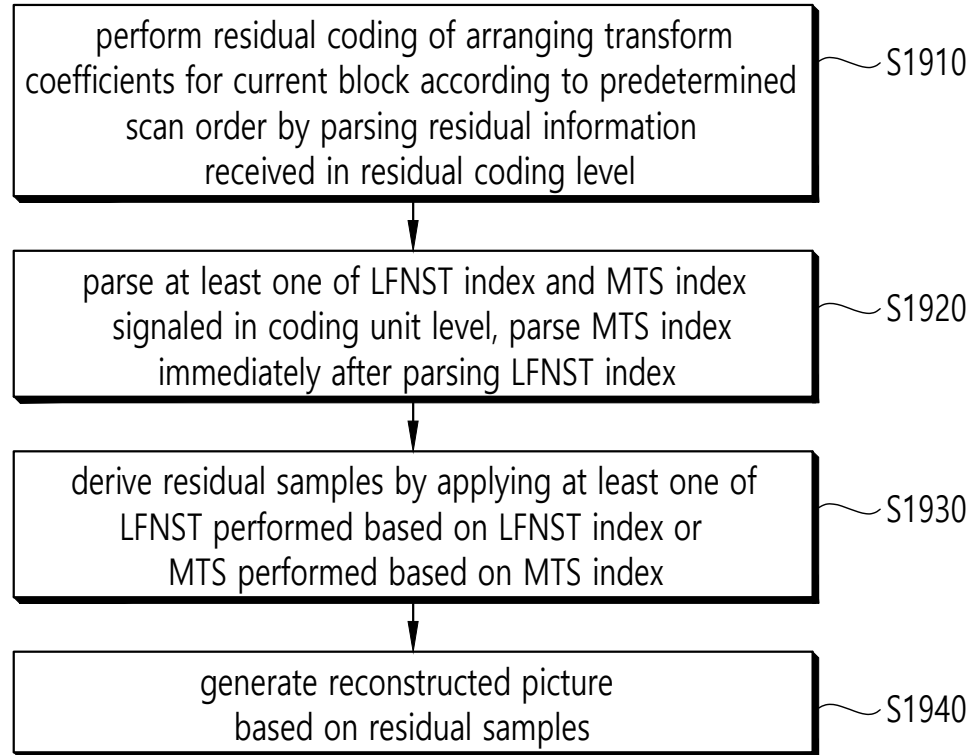

FIG. 20

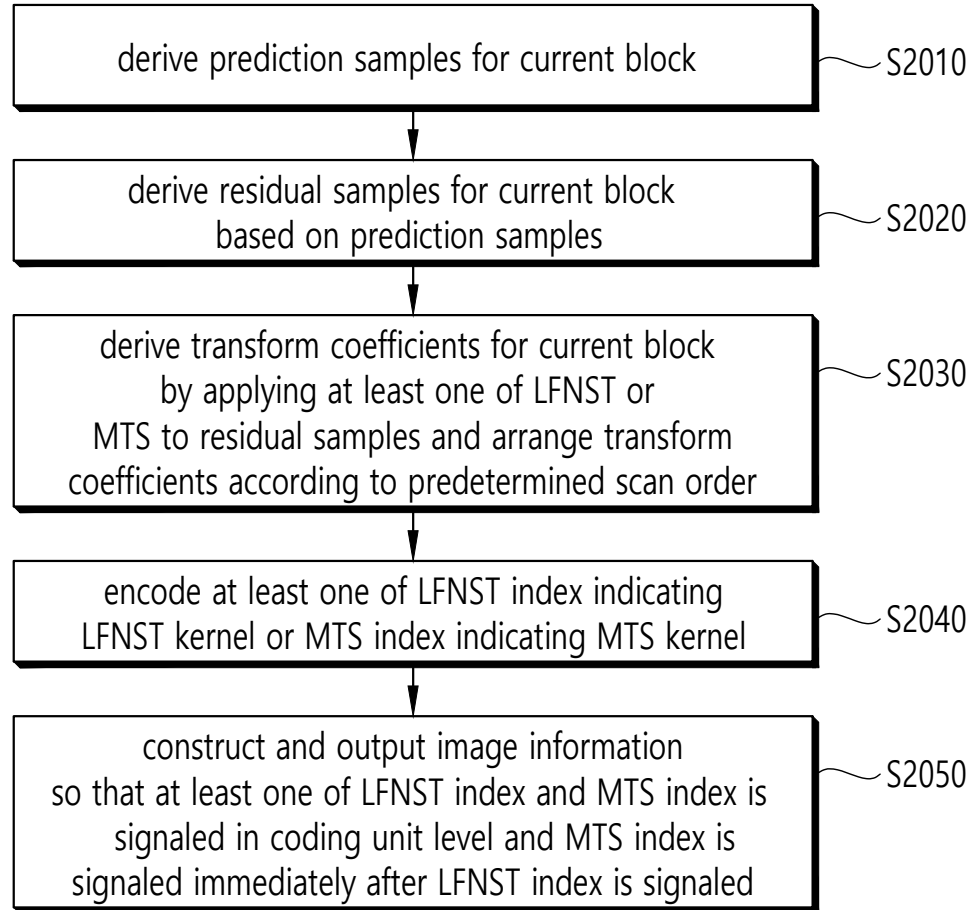

FIG. 21

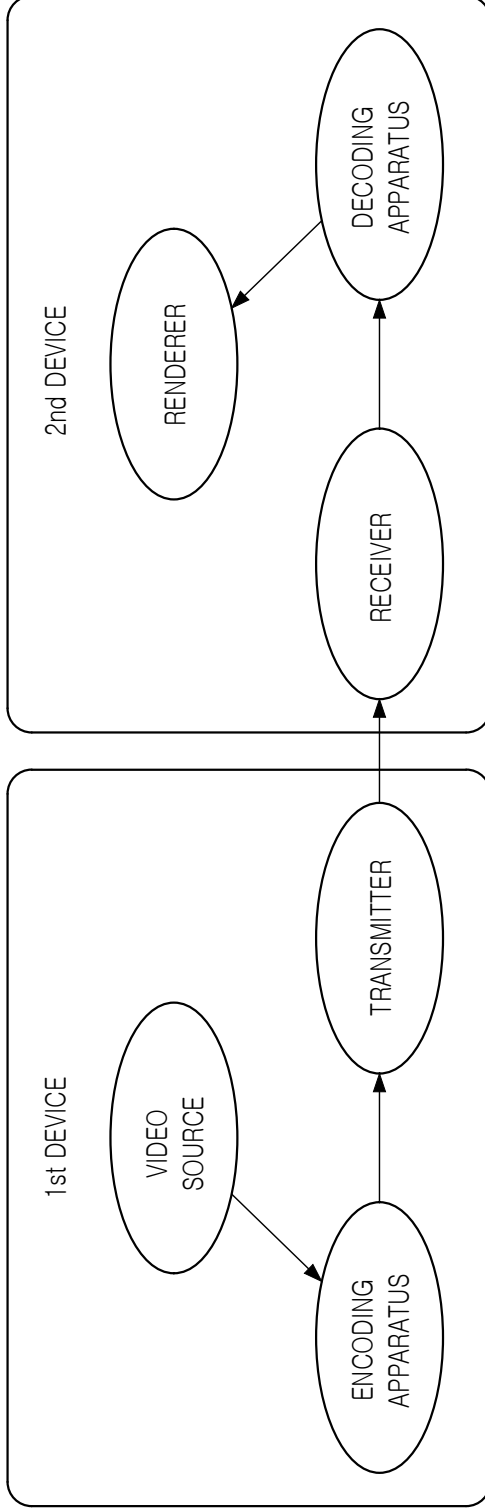

FIG. 22

