

(12) STANDARD PATENT APPLICATION (11) Application No. AU 2026201867 A1
(19) AUSTRALIAN PATENT OFFICE

(54) Title
High intensity illumination systems and methods of use thereof

(51) International Patent Classification(s)
A01M 7/00 (2006.01) **A01M 21/04** (2006.01)
A01M 21/00 (2006.01) **G03B 15/03** (2021.01)
A01M 21/02 (2006.01)

(21) Application No: **2026201867** (22) Date of Filing: **2026.03.12**

(43) Publication Date: **2026.04.02**

(43) Publication Journal Date: **2026.04.02**

(62) Divisional of:
2022380472

(71) Applicant(s)
Carbon Autonomous Robotic Systems Inc.

(72) Inventor(s)
SERGEEV, Alexander Igorevich; MIKESELL, Paul Anthony

(74) Agent / Attorney
Spruson & Ferguson, GPO Box 3898, Sydney, NSW, 2001, AU

2026201867 12 Mar 2026

HIGH INTENSITY ILLUMINATION SYSTEMS AND METHODS OF USE THEREOF
ABSTRACT

A system for illuminating and targeting a target, the target being a plant in a field. The system comprises a lighting array comprising a plurality of lights, wherein the lighting array is configured to evenly illuminate a region of interest in the field, and wherein the region of interest includes the plant and a detection system. The detection system comprises a camera configured to obtain an image of the region of interest, wherein the image depicts the plant, one or more processors configured to determine a target location of the plant in the region of interest based on the image of the region of interest obtained by the camera, and an implement configured to manipulate the plant at the target location.

HIGH INTENSITY ILLUMINATION SYSTEMS AND METHODS OF USE THEREOF**CROSS-REFERENCE**

[0001] The present application is a divisional of Australian Patent Application No. 2022380472, entitled “HIGH INTENSITY ILLUMINATION SYSTEMS AND METHODS OF USE THEREOF,” filed on November 1, 2022 and claims the benefit of U.S. Provisional Application No. 63/274,686, entitled “HIGH INTENSITY ILLUMINATION SYSTEMS AND METHODS OF USE THEREOF,” filed on November 2, 2021, which application is herein incorporated by reference in its entirety for all purposes.

BACKGROUND

[0002] Accuracy of automated object detection in an image is highly dependent on the quality of the image. Furthermore, training systems for automated object detection in images collected under inconsistent imaging conditions requires large amounts of training data to account for variations in imaging conditions. There is a need for systems to generate consistent imaging conditions for automated object detection in a variety of irregular environments.

SUMMARY

[0002a] An aspect of the present invention provides a system for illuminating and targeting a target, the target being a plant in a field, the system comprising: a lighting array comprising a plurality of lights, wherein the lighting array is configured to evenly illuminate a region of interest in the field, and wherein the region of interest includes the plant; and a detection system comprising: a camera configured to obtain an image of the region of interest, wherein the image depicts the plant, one or more processors configured to determine a target location of the plant in the region of interest based on the image of the region of interest obtained by the camera, and an implement configured to manipulate the plant at the target location.

[0002b] Another aspect of the present invention provides a system for illuminating and targeting weeds in a field, wherein the system is moveable over the field, the system comprising: a camera configured to obtain images of a region of interest in the field; a lighting array comprising a plurality of lights, wherein the lighting array is configured to evenly illuminate the region of interest in the field; an implement; and one or more processors configured to: activate the lighting array to evenly illuminate the region of interest, obtain an image of the region of interest from the camera while the region of interest is illuminated, identify a weed in the image of the region of interest, wherein the identifying is performed using a neural network configured to differentiate between weeds and crops, determine a target location of the weed in the region of interest, and cause the implement to manipulate the weed at the target location.

[0002c] There is disclosed herein a system for illuminating and targeting a target, the target being a plant in a field, the system comprising: a lighting array comprising a plurality of lights, wherein the lighting array is configured to illuminate a region of interest in the field to reduce or eliminate shadows in the region of interest, and wherein the region of interest includes the plant; and a detection system comprising: a camera configured to obtain an image of the region of interest, wherein the image depicts the plant, one or more processors configured to determine a target location of the plant in the region of interest based on the image of the region of interest obtained by the camera, and a light source configured to emit a light beam toward the target location of the plant to damage or kill the plant.

[0002d] There is also disclosed herein a system for illuminating and targeting weeds in a field, wherein the system is moveable over the field, the system comprising: a camera configured to obtain images of a region of interest in the field; a lighting array comprising a plurality of lights, wherein the lighting array is configured to illuminate the region of interest in the field to reduce or eliminate shadows in the images of the region of interest obtained by the camera; a light source configured to emit a light beam toward a target, wherein the target is a weed; and one or more processors configured to perform operations comprising: activating the lighting array to illuminate the region of interest, obtaining an image of the region of interest from the camera while the region of interest is illuminated, deactivating the lighting array, identifying a weed in the image of the region of interest, wherein the identifying is performed using a neural network configured to differentiate between weeds and crops, determining a target location of the weed in the region of interest based on the image, and causing the light source to emit the light beam toward the target location of the weed to kill or damage the weed.

[0003] In various aspects, the present disclosure provides an object targeting system comprising: a lighting array comprising a plurality of light emitters configured to emit light and illuminate a region of interest with an illuminance that is brighter than ambient illumination, wherein the region of interest defines an area on a surface; and a detection system comprising: a camera configured to image the region of interest, wherein the region of interest contains an object to be targeted, an object location module configured to determine an object location based on an image of the object collected by the camera, and an implement configured to target the object at the object location.

[0004] In some aspects, the illuminance within the region of interest is consistent over a depth of field range of not less than 8 cm when the lighting array is activated. In some aspects, the illuminance within the region of interest is consistent over the region of interest when the lighting array is activated. In some aspects, the illuminance within the region of interest is consistent over an area of at least 0.1 m² when the lighting array is activated. In some aspects,

the ambient illumination comprises sunlight. In some aspects, the lighting array is configured to produce an illuminance of not less than 120,000, not less than 240,000, or not less than 360,000 lumens per m² (lux). In some aspects, the lighting array is configured to produce an illuminance of not less than 200,000 lux and not more than 700,000 lux.

[0005] In some aspects, the illuminance within the region of interest varies by no more than 50% from day to night when the lighting array is activated. In some aspects, the illuminance within the region of interest varies by no more than 20% from day to night when the lighting array is activated. In some aspects, the illuminance within the region of interest varies by no more than 50% across the region of interest when the lighting array is activated. In some aspects, the illuminance within the region of interest varies by no more than 20% across the region of interest when the lighting array is activated.

[0006] In some aspects, the plurality of light emitters is arranged in a line, a circle, an oval, an irregular pattern, or a combination thereof. In some aspects, the camera has an exposure time of not more than 1.5 ms. In some aspects, the camera has a resolution of not less than 100 pixels per inch.

[0007] In some aspects, the object targeting system is coupled to a vehicle, wherein the vehicle is configured to move relative to the surface. In some aspects, the detection system is coupled to the vehicle such that the region of interest imaged by the detection system is underneath the vehicle. In some aspects, the lighting array is coupled to the vehicle such that the region of interest illuminated by the lighting array is underneath the vehicle. In some aspects, the vehicle is capable of moving at a speed of not less than 2 km/hr or not less than 1.2 miles/hr relative to the surface. In some aspects, the vehicle is capable of moving at a speed of not less than 2 km/hr and not more than 8 km/hr or not less than 1.2 miles/hr and not more than 5.0 miles/hr relative to the surface.

[0008] In some aspects, the object targeting system further comprises a computer and a strobe circuit module, wherein the computer is configured to control the strobe circuit module, and wherein the strobe circuit module is configured to activate and deactivate the lighting array and to synchronize an exposure time of the camera to an activation state of the lighting array. In some aspects, the strobe circuit module is configured to activate the lighting array when the exposure time of the camera begins and to deactivate the lighting array when the exposure time of the camera ends.

[0009] In some aspects, the surface is a ground surface. In some aspects, the surface is an agricultural surface. In some aspects, the object is a plant. In some aspects, the object is a weed. In some aspects, the surface is a construction surface. In some aspects, the implement is a laser. In some aspects, the laser is configured to burn the object. In some aspects, the implement is a

sprayer. In some aspects, the sprayer is configured to spray the object. In some aspects, the implement is a grabber. In some aspects, the grabber is configured to move the object. In some aspects, the light emitters are light emitting diodes (LEDs).

[0010] In various aspects, the present disclosure provides a method of targeting an object, the method comprising: (a) activating a lighting array comprising a plurality of light emitters to emit light and illuminate a region of interest defining an area on a surface with an illuminance that is brighter than ambient illumination; (b) collecting, via a camera, an image of the region of interest over an exposure time corresponding to a time between initiating collection of the image and terminating collection of the image; (c) terminating collection of the image; (d) deactivating the lighting array; (e) determining a location of the object based on the image; and (f) targeting the object with an implement at the location.

[0011] In some aspects, the method comprises illuminating the region of interest with an illuminance of not less than 120,000, not less than 240,000, or not less than 360,000 lumens per m² (lux). In some aspects, the method comprises illuminating the region of interest with an illuminance of not less than 200,000 lux and not more than 700,000 lux. In some aspects, the method comprises illuminating the region of interest with an illuminance that varies by no more than 50% or no more than 20% from day to night. In some aspects, the method comprises illuminating the region of interest with an illuminance that varies by no more than 50% or no more than 20% across the region of interest. In some aspects, the method comprises the ambient illumination comprises sunlight.

[0012] In some aspects, the method further comprises repeating steps (a) – (c) with a period corresponding to a camera frame rate. In some aspects, the exposure time is not more than 7% or not more than 15% of the camera frame rate. In some aspects, the exposure time is not less than 2% and not more than 15% of the camera frame rate. In some aspects, the lighting array and the camera are coupled to a vehicle such that the region of interest illuminated by the lighting array is located underneath the vehicle.

[0013] In some aspects, the implement is coupled to the vehicle. In some aspects, the vehicle is moving relative to the surface. In some aspects, the vehicle is moving relative to the surface at a speed of not less than 2 km/hr and not more than 8 km/hr or not less than 1.2 miles/hr and not more than 5.0 miles/hr.

[0014] In some aspects, the exposure time is not more than 1.5 ms. In some aspects, the exposure time is not more than 500 μs. In some aspects, a resolution of the image is not less than 100 pixels per inch.

[0015] In some aspects, the method comprises performing step (a) and initiating step (b) within 0.1 ms or within 10 μs of each other, wherein step (a) is performed before step (b) is initiated, or

wherein step (b) is initiated before step (a) is performed. In some aspects, the method comprises activating the light array within 0.1 ms or within 10 μ s of initiating collection of the image. In some aspects, the method comprises activating the light array before initiating collection of the image. In some aspects, the method comprises activating the light array after initiating collection of the image. In some aspects, the method comprises performing step (a) simultaneously with initiating step (b). In some aspects, the method comprises activating the lighting array and initiating collection of the image simultaneously.

[0016] In some aspects, the method comprises performing steps (c) and (d) within 0.1 ms or within 10 μ s of each other, wherein step (c) is performed before step (d) or step (d) is performed before step (c). In some aspects, the method comprises deactivating the light array within 0.1 ms or within 10 μ s of terminating collection of the image. In some aspects, the method comprises deactivating the light array before terminating collection of the image. In some aspects, the method comprises deactivating the light array after terminating collection of the image. In some aspects, the method comprises performing steps (c) and (d) simultaneously. In some aspects, the method comprises deactivating the lighting array and terminating collection of the image simultaneously.

[0017] In some aspects, targeting the object with the implement comprises burning the object with a laser. In some aspects, targeting the object with the implement comprises spraying the object with a sprayer. In some aspects, targeting the object with the implement comprises moving the object with a grabber. In some aspects, the object is a weed.

[0018] In various aspects, the present disclosure provides a system for illuminating a region of interest on a surface, the system comprising a lighting array comprising a plurality of light emitters configured to emit light toward the region of interest, the light array configured to illuminate the region of interest with an illuminance that is brighter than ambient illumination, wherein the region of interest defines an area on the surface, and wherein the high intensity illumination system provides consistent illumination within a depth of field range of at least 8 cm.

[0019] In some aspects, the plurality of light emitters produces an illuminance of not less than 120,000 lumens per m² (lux). In some aspects, the plurality of light emitters produces an illuminance of not less than 240,000 lux. In some aspects, the plurality of light emitters produces an illuminance of not less than 360,000 lux. In some aspects, the plurality of light emitters produces an illuminance of not less than 200,000 lux and not more than 700,000 lux. In some aspects, the ambient illumination comprises sunlight.

[0020] In some aspects, the surface is a ground surface. In some aspects, the surface is an agricultural surface. In some aspects, the surface is a construction surface.

[0021] In some aspects, the illumination is consistent over an area of at least 0.1 m^2 . In some aspects, the plurality of light emitters is arranged in a line, a circle, an oval, an irregular pattern, or a combination thereof. In some aspects, an arrangement of the plurality of light emitters produces even illumination of the surface. In some aspects, one or more light emitters of the plurality of light emitters are angled relative to other light emitters of the plurality of light emitters. In some aspects, the plurality of light emitters comprises light emitting diodes (LEDs).

[0022] In some aspects, the illuminance at the surface varies by no more than 50% from day to night. In some aspects, the illuminance at the surface varies by no more than 20% from day to night. In some aspects, the illuminance at the surface varies by no more than 50% across the region of interest. In some aspects, the illuminance at the surface varies by no more than 20% across the region of interest.

[0023] In some aspects, the system further comprises a camera configured to image the region of interest. In some aspects, the camera images the region of interest with an exposure time of no more than 1.5 ms. In some aspects, the camera images the region of interest with a resolution of not less than 100 pixels per inch.

[0024] In various aspects, the present disclosure provides a system for controlling a lighting array, the system comprising a computer, a strobe circuit module, a lighting array having a plurality of light emitters, and a camera; wherein the computer is configured to control the strobe circuit module, and wherein the strobe circuit module is configured to turn the light emitters on and off and to synchronize an exposure time of the camera to an on/off state of the plurality of light emitters.

[0025] In some aspects, the system further comprises a capacitor, wherein the capacitor is configured to charge while the plurality of light emitters is in an off state. In some aspects, discharging the capacitor is configured to turn on the plurality of light emitters. In some aspects, the system further comprises a heat sink configured to dissipate heat from the plurality of light emitters. In some aspects, the strobe circuit module is configured to operate the plurality of light emitters with a duty ratio of no more than 15%. In some aspects, the strobe circuit module is configured to operate the plurality of light emitters with a duty ratio of no more than 7%. In some aspects, the strobe circuit module is configured to operate the plurality of light emitters with a duty ratio of not less than 2% and not more than 15%. In some aspects, the strobe circuit module is configured to expose the camera while the plurality of light emitters are on. In some aspects, the strobe circuit module is configured to provide a voltage of at least double a recommended voltage at which the plurality of light emitters were designed to operate.

[0026] In some aspects, the lighting array is configured to produce an illuminance of least $120,000 \text{ lumens per m}^2$ (lux). In some aspects, the lighting array is configured to produce an

illuminance of at least 240,000 lux. In some aspects, the lighting array is configured to produce an illuminance of at least 360,000 lux. In some aspects, the lighting array is configured to produce an illuminance of from 200,000 lux to 700,000 lux.

[0027] In some aspects, the camera is configured to operate with an exposure time of at most 1.5 ms. In some aspects, the camera is configured to operate with an exposure time of at most 500 μ s.

[0028] In various aspects, the present disclosure provides a method of illuminating a region of interest on a surface, the method comprising: emitting light from a high intensity illumination system including a lighting array having a plurality of light emitters to emit the light; directing the light toward the region of interest defining an area on the surface; and illuminating the region of interest with an illuminance of at least 120,000 lumens per m^2 (lux) consistently across the region of interest within a depth of field range of at least 8 cm or at least 3.1 in.

[0029] In some aspects, the method comprises illuminating the region of interest consistently over an area of at least 0.1 m^2 . In some aspects, the method comprises illuminating the region of interest with an illuminance that varies by no more than 50% from day to night. In some aspects, the method comprises illuminating the region of interest with an illuminance that varies by no more than 20% from day to night. In some aspects, the method comprises illuminating the region of interest with an illuminance that varies by no more than 50% across the region of interest. In some aspects, the method comprises illuminating the region of interest with an illuminance that varies by no more than 20% across the region of interest.

[0030] In some aspects, the method further comprises turning the plurality of light emitters on and off in an on/off cycle. In some aspects, the method comprises turning on the plurality of light emitters for not more than 15% of the on/off cycle. In some aspects, the method comprises turning on the plurality of light emitters for not more than 7% of the on/off cycle. In some aspects, the method comprises turning on the plurality of light emitters for not less than 2% and not more than 15% of the on/off cycle.

[0031] In some aspects, the method further comprises imaging the region of interest with a camera to collect an image. In some aspects, an exposure time of the camera is synchronized with an on state of the light emitters. In some aspects, the plurality of light emitters is on while the camera is exposing. In some aspects, the exposure time of the camera is not more than 1.5 ms. In some aspects, the exposure time of the camera is not more than 500 μ s. In some aspects, the image collected by the camera comprises a resolution of at least 100 pixels per inch. In some aspects, the image has reduced motion blurring compared to an image without illuminating the region of interest with the lighting array.

[0032] In some aspects, the method further comprises identifying and/or locating an object in the image. In some aspects, the object is located on, above, or below the surface.

[0033] In some aspects, the high intensity illumination system is coupled to a vehicle. In some aspects, the method further comprises moving the vehicle relative to the surface. In some aspects, the vehicle is moving at a speed of not less than 2 km/hr and not more than 8 km/hr or not less than 1.2 miles/hr and not more than 5.0 miles/hr relative to the surface. In some aspects, the vehicle is moving at a speed of not less than 2 km/hr or not less than 1.2 miles/hr relative to the surface.

INCORPORATION BY REFERENCE

[0034] All publications, patents, and patent applications mentioned in this specification are herein incorporated by reference to the same extent as if each individual publication, patent, or patent application was specifically and individually indicated to be incorporated by reference.

BRIEF DESCRIPTION OF THE DRAWINGS

[0035] The novel features of the invention are set forth with particularity in the appended claims. A better understanding of the features and advantages of the present invention will be obtained by reference to the following detailed description that sets forth illustrative embodiments, in which the principles of the invention are utilized, and the accompanying drawings of which:

[0036] **FIG. 1A** illustrates a front view of an autonomous weed eradication vehicle, a detection system, and lighting array, in accordance with one or more embodiments herein;

[0037] **FIG. 1B** illustrates an isometric view of an autonomous weed eradication vehicle, a detection system, and lighting array, in accordance with one or more embodiments herein;

[0038] **FIG. 1C** illustrates a top-down view of a surface underneath an autonomous weed eradication vehicle, showing coverage area of a lighting array, in accordance with one or more embodiments herein;

[0039] **FIG. 2** shows example images of regions of interest illuminated using a high intensity illumination system, in accordance with one or more embodiments herein;

[0040] **FIG. 3** shows images of a region of interest collected without high intensity illumination;

[0041] **FIG. 4A** shows an example image of a region of interest illuminated with 600,000 lux collected with an exposure time of 0.3 ms, while moving at a speed of 2 miles per hour, in accordance with one or more embodiments herein;

[0042] **FIG. 4B** illustrates simulated motion blurring when imaging a region of interest illuminated with 120,000 lux while moving at a speed of 2 miles per hour;

- [0043] FIG. 4C illustrates simulated motion blurring when imaging a region of interest illuminated with 60,000 lux while moving at a speed of 2 miles per hour;
- [0044] FIG. 5A schematically illustrates a bottom view of a lighting array for a high intensity illumination system, in accordance with one or more embodiments herein;
- [0045] FIG. 5B schematically illustrates an isometric bottom view of a lighting array for a high intensity illumination system, in accordance with one or more embodiments herein;
- [0046] FIG. 6A schematically illustrates bottom views of a lighting array for a high intensity illumination system, in accordance with one or more embodiments herein;
- [0047] FIG. 6B schematically illustrates a bottom view of a vehicle with multiple lighting arrays for a high intensity illumination system configured on an autonomous weed eradication vehicle, in accordance with one or more embodiments herein;
- [0048] FIG. 7 schematically illustrates a system for synchronizing a high intensity illumination system and a detection system, in accordance with one or more embodiments herein;
- [0049] FIG. 8 schematically illustrates a surface illuminated with high intensity illumination, in accordance with one or more embodiments herein;
- [0050] FIG. 9 schematically illustrates an electrical configuration for powering a high intensity illumination system, in accordance with one or more embodiments herein;
- [0051] FIG. 10 depicts a system for identifying, locating, targeting, and manipulating an object, in accordance with one or more embodiments herein;
- [0052] FIG. 11A illustrates an isometric view of a portion of a detection system with the laser path and visible light path indicated, in accordance with one or more embodiments herein;
- [0053] FIG. 11B illustrates a top view of a portion of a detection system with the laser path and visible light path indicated, in accordance with one or more embodiments herein;
- [0054] FIG. 12 schematically illustrates a method of targeting an object using a high intensity illumination system, in accordance with one or more embodiments herein;
- [0055] FIG. 13A is a block diagram illustrating a computing device, according to example embodiments.
- [0056] FIG. 13B is a block diagram illustrating a computing device, according to example embodiments.

DETAILED DESCRIPTION

[0057] Various example embodiments of the disclosure are discussed in detail below. While specific implementations are discussed, it should be understood that this description is for illustration purposes only. A person skilled in the relevant art will recognize that other components and configurations may be used without parting from the spirit and scope of the

disclosure. Thus, the following description and drawings are illustrative and are not to be construed as limiting. Numerous specific details are described to provide a thorough understanding of the disclosure. However, in certain instances, well-known or conventional details are not described in order to avoid obscuring the description. References to one or an embodiment in the present disclosure can be references to the same embodiment or any embodiment and, such references mean at least one of the example embodiments.

[0058] Reference to “one embodiment” or “an embodiment” means that a particular feature, structure, or characteristic described in connection with the embodiment is included in at least one embodiment of the disclosure. The appearances of the phrase “in one embodiment” in various places in the specification are not necessarily all referring to the same embodiment, nor are separate or alternative example embodiments mutually exclusive of other example embodiments. Moreover, various features are described which may be exhibited by some example embodiments and not by others. Any feature of one example can be integrated with or used with any other feature of any other example.

[0059] The terms used in this specification generally have their ordinary meanings in the art, within the context of the disclosure, and in the specific context where each term is used. Alternative language and synonyms may be used for any one or more of the terms discussed herein, and no special significance should be placed upon whether or not a term is elaborated or discussed herein. In some cases, synonyms for certain terms are provided. A recital of one or more synonyms does not exclude the use of other synonyms. The use of examples anywhere in this specification including examples of any terms discussed herein is illustrative only and is not intended to further limit the scope and meaning of the disclosure or of any example term. Likewise, the disclosure is not limited to various example embodiments given in this specification.

[0060] Without intent to limit the scope of the disclosure, examples of instruments, apparatus, methods, and their related results according to the example embodiments of the present disclosure are given below. Note that titles or subtitles may be used in the examples for convenience of a reader, which in no way should limit the scope of the disclosure. Unless otherwise defined, technical and scientific terms used herein have the meaning as commonly understood by one of ordinary skill in the art to which this disclosure pertains. In the case of conflict, the present document, including definitions will control.

[0061] Additional features and advantages of the disclosure will be set forth in the description which follows, and in part will be obvious from the description, or can be learned by practice of the herein disclosed principles. The features and advantages of the disclosure can be realized and obtained by means of the instruments and combinations particularly pointed out in the appended

claims. These and other features of the disclosure will become more fully apparent from the following description and appended claims or can be learned by the practice of the principles set forth herein.

[0062] For clarity of explanation, in some instances the present technology may be presented as including individual functional blocks representing devices, device components, steps or routines in a method embodied in software, or combinations of hardware and software.

[0063] In the drawings, some structural or method features may be shown in specific arrangements and/or orderings. However, it should be appreciated that such specific arrangements and/or orderings may not be required. Rather, in some embodiments, such features may be arranged in a different manner and/or order than shown in the illustrative figures.

Additionally, the inclusion of a structural or method feature in a particular figure is not meant to imply that such feature is required in all embodiments and, in some embodiments, it may not be included or may be combined with other features.

[0064] While the concepts of the present disclosure are susceptible to various modifications and alternative forms, specific embodiments thereof have been shown by way of example in the drawings and will be described herein in detail. It should be understood, however, that there is no intent to limit the concepts of the present disclosure to the particular forms disclosed, but on the contrary, the intention is to cover all modifications, equivalents, and alternatives consistent with the present disclosure and the appended claims.

[0064a] The reference in this specification to any prior publication (or information derived from it), or to any matter which is known, is not an acknowledgment or admission or any form of suggestion that that prior publication (or information derived from it) or known matter forms part of the common general knowledge in the field of endeavor to which this specification relates.

High Intensity Illumination Systems and Methods

[0065] The present disclosure provides systems and methods to produce consistent, high-intensity illumination over a region of interest on a surface. Such systems and methods may enable collection of high quality, high resolution, and/or short exposure images of the region of interest, independent of ambient light (e.g., solar illumination in an outdoor environment). Collection of consistent high quality, high resolution, and/or short exposure images may be beneficial for a number of applications, including automated object detection, which depends on quality and consistency of images to recognize objects within the image. Automated object detection often uses machine learning software trained with training image sets containing known objects. In these cases, accuracy of object detection in an image depends on consistency

between the training data and the image, as well as a high level of image clarity and definition. For images collected under highly variable conditions, large amounts of training data may be needed to account for these variable conditions. For blurred or low-quality images (e.g., low resolution, overexposed, or underexposed) even large amounts of training may be unable to account for image variations because the object features may not be discernable. Collecting images under consistent, high intensity illumination, such as with the systems and methods described herein, substantially reduces the amount of training data needed to train object recognition software. In some embodiments, an automated object detection system trained using training images collected under illumination of a high intensity illumination system may require 10-fold to 100-fold fewer images to train the system than an automated object detection system trained using training images collected without high intensity illumination. For examples, an automated object detection system trained using training images collected under illumination of a high intensity illumination system may require about 25 to 250, about 50 to 500, or about 75 to 750 training images, and an automated object detection system trained using training images collected without high intensity illumination may require about 250 to 2500, about 500 to 5000, or about 750 to 7500 training images. Additionally, imaging a region of interest illuminated with high intensity illumination may be performed at higher resolution and/or shorter exposure time than imaging performed under ambient or lower intensity lighting conditions since increasing the resolution and shortening the exposure time both reduce the amount of light received per pixel.

[0066] Described herein are high intensity illumination systems for illuminating a region of interest on a surface. Such high intensity illumination may facilitate imaging the surface by providing bright, uniform illumination of the region of interest. A high intensity illumination system comprising a lighting array may be configured to illuminate a surface with even illumination across a region of interest such that images collected of the region of interest are not overexposed or underexposed in parts of the image due to shadows or irregular lighting. The surface may be a rugged surface, such as a dirt surface. Examples of images with overexposed areas due to glare from the sun that were collected without use of a high intensity illumination system are shown in **FIG. 3**. The images provided in **FIG. 3** contain clipped regions in which the light level in the region is either below a threshold of detection of the camera (underexposed) or saturating the camera (overexposed). Overexposed areas are denoted with shaded arrows. Example images of regions of interest **162** containing objects **161** illuminated with a high intensity illumination system as described herein are shown in **FIG. 2**.

[0067] A high intensity illumination system of the present disclosure may provide bright, even illumination of a region of interest (e.g., a region on a surface underneath a vehicle) despite

changes in ambient lighting conditions. The high intensity illumination system may illuminate the region of interest with an intensity that is multiple times brighter than ambient illumination (e.g., sunlight), such that the ambient illumination does not cause uneven illumination across the region of interest. For example, the high intensity illumination system may evenly illuminate the region of interest over the course of a day as the angle and intensity of sunlight changes. The high intensity illumination system may provide even illumination across the region of interest without use of a light-blocking shroud or skirt to block ambient light from reaching the region of interest.

[0068] A high intensity illumination system may evenly illuminate a region of interest (e.g., a region on a surface underneath a vehicle) such that an image collected of the region of interest (e.g., an image collected by a camera) is not over- or under-exposed, also referred to as “clipped.” In some embodiments, a light level across the region of interest may be within a dynamic range of a camera used to collect an image of the region of interest. In contrast, an image collected of a region that is not illuminated with a high intensity illumination system may contain regions that are over-exposed (e.g., saturating the camera used to collect the image), under-exposed (e.g., below a detection threshold of the camera used to collect the image), or both. For example, an image collected of a region that is not illuminated with a high intensity illumination system may be clipped such that

[0069] A high intensity illumination system may facilitate collection of color images of a region illuminated by the high intensity illumination system. A color image may be collected using two or more color channels, such as an RGB image collected using red, blue, and green color channels. A region of interest illuminated by a high intensity illumination system may be illuminated such that intensities collected in each color channel (e.g., each of a red channel, a green channel, and a blue channel) are within a dynamic range of the image sensor, such that none of the channels are clipped (e.g., overexposed or underexposed). In some embodiments, the intensities collected in each color channel (e.g., each of a red channel, a green channel, and a blue channel) may be within a standard deviation of each other. For example, the mean intensity of the red channel may be within a standard deviation of the mean intensities of each of the green channel and the blue channel, the mean intensity of the blue channel may be within a standard deviation of the mean intensities of each of the green channel and the red channel, the mean intensity of the green channel may be within a standard deviation of the mean intensities of each of the red channel and the blue channel, or a combination thereof.

[0070] Also described herein are methods of illuminating a surface using a high intensity illumination system and imaging the illuminated surface with high resolution (e.g., at least 100 pixels per inch or at least 200 pixels per inch) and/or short exposure time (e.g., no more than 1.5

ms or no more than 300 μ s). These methods may be used to illuminate and image a surface (e.g., a dirt surface) and to identify and/or locate objects (e.g., plants or weeds) in the images. In some embodiments, the high intensity illumination systems may be incorporated into a vehicle (e.g., an autonomous vehicle) to illuminate an area under, in front of, behind, or around the vehicle. In some embodiments, the high intensity illumination methods described herein may be used to facilitate object identification and/or location in a farming, agricultural, or construction environment.

[0071] A high intensity illumination system of the present disclosure may comprise a plurality of light emitters, such as emitting diodes (LEDs), arranged in a lighting array. The light emitters may be configured to emit light toward a surface and illuminate a region of the surface (e.g., a region of interest of the surface). The light emitters may provide even illumination across the region and over a depth of field range of at least 5 cm, at least 8 cm, at least 12 cm, or at least 12.7 cm. The illumination may be substantially uniform across a region of the surface that is at least 0.1 m², least 0.15 m², least 0.2 m², or least 0.25 m². In some embodiments, the illumination brightness may vary by no more than 5%, no more than 10%, no more than 20%, no more than no more than 30%, no more than 40%, or no more than 50% across the region of the surface.

[0072] The high intensity illumination system may be configured to illuminate the surface with an illuminance that is comparable to or brighter than ambient lighting conditions (e.g., the sun, interior lighting, or exterior lighting). The illuminance may be twice, three times, four times, or five times as bright as ambient lighting conditions. For example, under daylight conditions where most ambient light is sunlight, the high intensity illumination may provide consistent illumination of a region of a surface (e.g., the ground) even as the sun changes positions relative to the surface throughout the day. In some embodiments, the high intensity illumination system may illuminate the region of the surface with illumination comparable to the illumination provided by the sun on a bright day. In some embodiments, the high intensity illumination system may illuminate the region of the surface with illumination that is twice, three times, four times, five times, six times, eight times, or ten times as bright as illumination provided by the sun on a bright day. In some embodiments, the high intensity illumination system may illuminate the region of the surface with an illuminance of at least 120,000 lumens per m² (lux), at least 240,000 lux, at least 360,000 lux, at least 600,000 lux, 800,000 lux, 1,000,000 lux, or 1,200,000 lux. In some embodiments, the high intensity illumination system may illuminate the region of the surface with an illuminance of from 200,000 lux to 700,000 lux, from 240,000 lux to 800,000 lux, from 300,000 lux to 1,000,000 lux, or from 400,000 lux to 1,200,000 lux.

[0073] High intensity illumination comparable to or brighter than ambient lighting conditions may enable imaging at all times of day or night without variations due to the presence, absence,

or angle of the sun. For example, the high intensity illumination system may provide even illumination without glare or shadowing across the region of the surface even when the sun encounters the surface at a low angle. For example, illumination intensity may change by no more than 20%, no more than 30%, no more than 40%, or no more than 50% from day to night. [0074] In some embodiments, a high intensity illumination system may be positioned on or part of a device, such as a vehicle. An example of a vehicle **100** equipped with a high intensity illumination system comprising a lighting array **150** is illustrated in **FIG. 1A**, **FIG. 1B**, and **FIG. 1C**. The lighting array may comprise one or more light emitters **151**, such as light emitting diodes (LEDs), configured to emit light **152** toward a surface **160**. As illustrated in **FIG. 1A**, **FIG. 1B**, and **FIG. 1C**, the lighting array **150** may be positioned on the underside of the vehicle **100** such that light **152** emitted from the lighting array illuminates a region of interest **162** on a surface underneath the vehicle. The vehicle may be capable of moving along the surface **160** using one or more wheels **110**. The region of interest **162** may contain an object **161** to be targeted by the detection system **101**. The surface may be a ground surface, such as in an agricultural or construction environment. For example, the agricultural surface may be a crop field or a greenhouse. In some embodiments, the vehicle may be further equipped with a detection system **101** comprising a camera for imaging a region of the surface illuminated by the high intensity illumination system. For example, an autonomous vehicle configured to image, detect, identify, locate, and/or eradicate weeds in a crop field may be equipped with a high intensity illumination system to imaging, detection, identification, and/or location of the weeds.

Lighting Arrays

[0075] The high intensity illumination systems described herein may comprise one or more lighting arrays including an array of light emitters configured to evenly illuminate a surface. Examples of lighting arrays **150** comprising one or more light emitters **151**, such as LEDs, are shown in **FIG. 5A**, **FIG. 5B**, **FIG. 6A**, and **FIG. 6B**. **FIG. 6B** further illustrates multiple lighting arrays **150** arranged on a vehicle **100**. **FIG. 5A** shows a bottom view of the lighting array **150**, and **FIG. 1B** shows an isometric bottom view of the lighting array, for example as viewed from the underside of vehicle **100**. **FIG. 6A** shows bottom view of different LED configurations for a lighting array **150**. **FIG. 6B** shows a bottom view of a vehicle **100** equipped with multiple lighting arrays **150** to illuminate a surface underneath the vehicle. A lighting array may further comprise a heat sink **155** to dissipate heat generated by operating the light emitters **151** and a power level higher than a manufacturer's recommended voltage or higher than a safety rated voltage. In some embodiments, the light emitters **151** of a lighting array **150** may be arranged to define a closed area, such as a rectangular region, as seen in **FIG. 5A** and **FIG. 6A**.

In some embodiments, the light emitters **151** of a lighting array **150** may be arranged to define other close areas, such as circular, oval, polygonal, or other shaped regions. The light emitters **151** of a lighting array **150** may be arranged to provide even illumination across a region of interest (e.g., a region imaged by a camera, such as region **162** of **FIG. 1C**) such that the sum of the illumination from a plurality of light emitters **151** of the lighting array **150** is even over the region of interest, as shown in **FIG. 8**. A light emitter **151** of a lighting array **150** may be surrounded by or positioned near a reflector **157** such that portions of the light **152** emitted by the light emitter that may not otherwise reach the surface are reflected toward the surface **160**. In some embodiments, a reflector **157** may be configured to increase the amount of light **152** from the light emitter **151** that reaches the surface **160**, spread the light **152** across the surface **160** such that the light more uniformly illuminates the surface, or combinations thereof. A reflector **157** may have a variety of shapes, including parabolic, hemispherical, elliptical, conical, cylindrical, curved, or portions or combinations thereof.

[0076] A plurality of light emitters **151** of a lighting array may be arranged to produce even illumination **165** over a region of surface **160** (e.g., region **162** of **FIG. 1C**). For example, a first light emitter **151(a)** may emit a first light **152(a)** to illuminate surface **160** with a first illumination **165(a)**, and a second light emitter **151(b)** may emit a second light **152(b)** to illuminate surface **160** with a second illumination **165(b)**, such that the total illumination **165** is even across a region of the surface **160**. In some embodiments, the light emitter **151** arrangement may be determined using computer modeling or experimental testing. A computer simulation to determine a light emitter arrangement may identify an arrangement of light emitters that produces even illumination over the region of interest while considering parameters including geometrical constraints for light emitter placement on the lighting array **150**, light dispersion from the light emitters, presence and/or type of reflectors, distance of the lighting array from the surface, size and/or shape of the region of interest, and combinations thereof. In some embodiments, the parameters that may be varied include position, number, and/or angle of light emitters, presence and/or type of reflectors, intensity of light emitters, or combinations thereof. The illumination may be the sum of illuminations from individual light emitters, as shown in **FIG. 8**. In some embodiments, the computer simulation may position the light emitters **151** to minimize an intensity variation across the region of interest of the surface **160**. In some embodiments, a light emitter configuration may include linear, circular, rectangular, or irregular placements of light emitters, or combinations thereof. In some embodiments, light emitter placement may be constrained by a size or shape of a device (e.g., a vehicle) on which the array is positioned. In some embodiments, light emitter placement may be constrained by positions of

additional components of the device such that the light emitters do not interfere with the additional components.

Control Systems

[0077] The high intensity illumination systems described herein may be controlled by a control system. The control system may control power to the light emitters (e.g., LEDs) of a lighting array and synchronize an on/off state of the LEDs to a camera shutter or exposure. An example of a control system **700** is provided in **FIG. 7**. A control system **700** may comprise a computer **701** configured to control a strobe circuit system **710** comprising a strobe control printed circuit board (PCB) **702**. The strobe PCB may provide a strobe signal (e.g., a pulsed voltage) to a lighting array **703** (e.g., an LED array). The strobe control PCB **702** may further provide a camera trigger signal to one or more cameras **704**. The one or more cameras may be part of a detection system **101**. Optionally, the control system may further comprise a strobe driver PCB **705** comprising one or more capacitors **706** connected to the strobe control PCB **702** and the lighting array **703**. The capacitors **706** of the PCB may accumulate charge while the light emitters of the lighting array **150** are in an off state and may discharge to turn on the light emitters. Since providing pulses of high wattage power to the light emitters of the lighting array **150** to turn them on and off may strain a power generation system, inclusion of the capacitors **706** may enable pulsed power while applying a more uniform load to the power generation system. For example, the capacitors **706** may provide pulsed power to the light emitters of a lighting array **150** while the power generation provides sustained power by charging the capacitors over time while the light emitters are off and discharging the capacitors to turn the light emitters on. Inclusion of the strobe driver PCB may reduce the peak power output of the power generation system compared to a system without a strobe driver PCB.

[0078] An example circuit configuration for controlling a lighting array **150** is provided in **FIG. 9**. A power supply unit (PSU) **720** may provide power to the strobe driver PCB **705**. A strobe signal **702** may control charging and discharging of the capacitors of the strobe driver PCB **705**, and the capacitors **706** may power the light emitters **151** when discharged. Individual lighting modules **750** may be chained together to form a lighting array **150**.

[0079] A control system, such as control system **700** illustrated in **FIG. 7**, may be configured to provide a voltage to the lighting array that is sufficient to power the light emitters of the light array to illuminate a surface with an illuminance that is comparable to or brighter than the sun (e.g., an illuminance of at least 120,000 lux, at least 240,000 lux, at least 400,000 lux, or at least 600,000 lux). The voltage provided to the light emitters by the strobe PCB may be higher than a manufacturer's recommended voltage or higher than a safety rated voltage for the light emitters.

In some embodiments, the voltage provided to the light emitters may be at least 1.2 times, at least 1.5 times, or at least 2 times the voltage at which the light emitters were designed to operate.

[0080] To compensate for the high voltage, the light emitters may be operated at a low duty ratio. Operating at a low duty ratio may reduce overheating caused by the high voltage and/or may extend the lifetime of the light emitters that may otherwise be shortened due to the high voltage. In some embodiments, the light emitters may be operated at a duty ratio of no more than 20%, no more than 15%, no more than 10%, no more than 7%, or from 2% to 15%. For example, a lighting array receiving double a recommended voltage may be operated at a duty ratio of no more than 10%. In some embodiments, the lighting array may further comprise a heat sink to dissipate excess heat and prolong the lifetime of the light emitters.

[0081] The duty ratio of the lighting array may be synchronized with a frame rate, shutter trigger, or exposure time of a camera. The camera may be configured to image a region illuminated by the lighting array. The strobe PCB may synchronize the lighting array and the camera such that the lighting array is on while the camera is collecting an image (e.g., while the camera shutter is open or while the camera is exposing a sensor chip). The camera may be operated with a fast frame rate (e.g., with an exposure time of no more than 1.5 ms or no more than 300 μ s). The strobe PCB may cycle the lighting array on and off to produce a strobing effect that is synchronized with the camera frame rate and/or exposure time.

Object Targeting Systems and Methods

[0082] A high intensity illumination system of the present disclosure may be part of an object targeting system such as a weed eradication system. A weed eradication system comprising a high intensity illumination system may be configured to autonomously locate, target, and kill weeds in an agricultural setting (e.g., a crop field or a greenhouse). In some embodiments, the high intensity illumination system may improve the accuracy of the weed eradication system, increase the rate of weed detection by the weed eradication system, increase the speed at which the weed eradication system can travel, or combinations thereof. A weed eradication system comprising a high intensity illumination system of the present disclosure may be able to detect weeds in images collected at higher resolution and/or shorter exposure time than a weed eradication system lacking a high intensity illumination system (e.g., a weed eradication system operating under ambient lighting conditions).

[0083] In some embodiments, a detection system of the present disclosure, comprising a prediction system and a targeting system, may be configured to identify and target an object using point to point targeting methods. The prediction system may comprise a prediction sensor

configured to image a region of interest, and the targeting system may comprise a targeting sensor configured to image a portion of the region of interest. Imaging may comprise collecting a representation (e.g., an image) of the region of interest or the portion of the region of interest. [0084] FIG. 10 schematically depicts a detection system 101 that may be used in conjunction with a high intensity illumination system to locate, and precisely target an object of interest 161. In some embodiments, a detection system may comprise an optical configuration depicted in FIG. 11A and FIG. 11B, as described herein. As illustrated in FIG. 10, the detection system 101, may be a multi-camera system, comprising a prediction module 1010 and a targeting module 1050. The detection system 101 may image a region of interest, such as prediction region of interest 1091, using a first sensor, such as a prediction sensor 1020. The prediction region of interest 1091 may be a region of a surface 160, such as the ground, a floor, or an agricultural field. The image may be a visible light image, an infrared image, an ultraviolet image, a light detection and ranging (LIDAR) image, an x-ray image, or any other electromagnetic image. The prediction sensor 1020 may be a camera, such as a charge-coupled device (CCD) camera or a complementary metal–oxide–semiconductor (CMOS) camera, a LIDAR detector, an infrared sensor, an ultraviolet sensor, an x-ray detector, or any other sensor capable of detecting electromagnetic waves.

[0085] An object identification module 1030 may receive the image from the prediction sensor 1020. The prediction module 1010 may determine the presence or absence of an object of interest 161 in an image of a region of interest, such as prediction region of interest 1091, collected by the prediction sensor 1020 using an object identification module 1030. The object identification module 1030 may identify objects of interest in the image and may differentiate objects of interest from other objects in the image. In some embodiments, the object identification module 1030 comprises an identification machine learning model trained to identify objects of interest based on features extracted from labeled images used for training the identification machine learning model. The machine learning model may be a deep learning model, such as a deep learning neural network. In some embodiments, the object identification module 1030 may implement a heuristic model, thresholding, or a classical detection algorithm to identify the object. In some embodiments, the object identification module identifies the object using spectroscopic data.

[0086] The object identification module may be configured to identify a plant and to differentiate between different plants, such as between a crop and a weed, for example using a machine learning model. In some embodiments, the machine learning model may be a deep learning model, such as a deep learning neural network. In some embodiments, the object identification module may utilize identification machine learning model, such as a convolutional

neural network. The identification machine learning model may be trained with many images for surfaces with or without objects of interest. For example, the machine learning model may be trained with images of fields with or without weeds. Once trained, the machine learning model may be configured to identify a region in the image containing an object of interest. The region may be defined by a polygon, for example a rectangle. In some embodiments, the region is a bounding box. In some embodiments, the region is a polygon mask covering an identified region. In some embodiments, the identification machine learning model may be trained to determine a location of the object of interest, for example a pixel location within a prediction image.

[0087] The location of the identified object may be communicated to an object location module **1040**. The object location module **1040** may send the location of the object **161** to a targeting module **1050**. In some embodiments, a detection system may lack a prediction module **1010** and the location of the object **161** may be determined directly from an image collected by the targeting sensor. In some embodiments, the targeting module **1050** is one of a plurality of targeting modules, and the targeting module **1050** may be selected based on availability of the targeting module or proximity of the targeting module to the object location.

[0088] A targeting control module **1055** of the targeting module **1050** may control the position, orientation, or direction of a targeting sensor **1060**. In some embodiments, the targeting control module **1055** may control the position, orientation, or direction of the targeting sensor **1060** by moving an actuator that adjusts the position or orientation of the targeting sensor **1060**. In some embodiments, the targeting control module **1055** may control the position, orientation, or direction of the targeting sensor **1060** by moving an actuator that adjusts the position or orientation of a reflective surface that directs electromagnetic waves to or from the targeting sensor **1060**.

[0089] The targeting sensor **1060**, the position, orientation, or direction of which may be adjusted by the targeting control module **1055** to point toward the object location, may collect an additional image of a region of interest, such as targeting region of interest **1093**, containing the object of interest **161**. The targeting region of interest **1093** may cover a portion of the prediction region of interest **1091** imaged by the prediction sensor **1020**. The additional image may be used to confirm or update the location of the object of interest **161**. Optionally, the targeting control module **1055** may adjust the position, orientation, or direction of an implement **1080** based on the location of the object **161** in an additional image collected by the targeting sensor. In some embodiments, the targeting control module **1055** may adjust the position, orientation, or direction of the implement **1080** by moving an actuator that adjusts the position or orientation of

the implement **1080**. In some embodiments, the targeting module may activate or inactivate select implements within an array of implements such that the object is selectively targeted. **[0090]** The implement **1080** may perform an action on the object **161** by directing the implement toward the object location. For example, the implement **1080** may be a laser that emits laser light toward the object **161**. In another example, the implement **1080** may be a grabbing tool that grabs the object **161**. In another example, the implement **1080** may be a spraying tool that sprays a fluid at the object **161**. In some embodiments, the implement **1080** may be a planting tool that plants a plant at the identified location. In some embodiments, the implement **1080** may be a harvesting tool that harvests the object **161**. In some embodiments, the implement **1080** may be a pollinating tool that pollinates the object **161**. In some embodiments, directing the implement toward the object location may comprise activating or inactivating select implements within an array of implements, such that the object is selectively targeted.

[0091] The detection system of an object targeting system comprising a high intensity illumination system may be configured to locate and target an object of interest. In some embodiments, a detection system may be used to target an object of interest identified in an image or representation collected by a sensor, such as a camera. The location of the object may be determined based on the image, and the object may be targeted at the determined location. Targeting the object may comprise precisely locating the object using the targeting sensor and targeting the object with an implement. For example, the detection system may comprise as a laser optical system to direct laser illumination toward the targeted object at a location determined by the object detection system.

[0092] An object targeting system may be configured to direct a beam, for example a light beam, toward a target location on a surface, such as a location of an object of interest. Referring to **FIG. 11A** and **FIG. 11B**, an exemplary object targeting system comprising a detection system will now be described. In the illustrated embodiments, the implement is a laser. However, other implements are within the scope of the present disclosure, including but not limited to a grabbing implement, a spraying implement, a planting implement, a harvesting implement, a pollinating implement, a marking implement, a blowing implement, or a depositing implement. In some embodiments, the implement may comprise an array of implements that may be selectively activated or inactivated to target the location of an object of interest. For example, an implement may comprise an array of sprayers, and each sprayer in the array is activated or inactivated depending on the location of the object of interest such that the location of an object of interest is selectively sprayed.

[0093] FIG. 11A illustrates an isometric view of an embodiment of a detection system **101** as disclosed herein. An emitter **1101**, such as a laser, is configured to direct a beam along an optical path, for example a laser path **1102**. In some embodiments, the beam comprises electromagnetic radiation, for example light, radio waves, microwaves, or x-rays. In some embodiments, the light is visible light, infrared light, or ultraviolet light. The beam may be coherent. In one embodiment, the emitter is a laser, such as an infrared laser.

[0094] One or more optical elements may be positioned in a path of the beam. The optical elements may comprise one or more of a beam combiner **1103**, a first reflective element **1105**, and a second reflective element **1106**. The elements may be configured in the order of the beam combiner **1103**, followed by the first reflective element **1105**, followed by the second reflective element **1106**, in the direction of the beam path.

[0095] In another example, one or both of the first reflective element **1105** or the second reflective element **1106** may be configured before the beam combiner **1103**, in order of the direction of the beam path. In another example, the optical elements may be configured in the order of the beam combiner **1103**, followed by the first reflective element **1105** in order of the direction of the beam path. In another example, one or both of the first reflective element **1105** or the second reflective element **1106** may be configured before the beam combiner **1103**, in the direction of the beam path. Any number of additional reflective elements may be positioned in the beam path. The beam may pass through a laser escape window **1107**. The laser escape window **1107** may be transparent and may protect the other optical elements from dust.

[0096] The beam combiner **1103** may also be referred to as a beam combining element. In some embodiments, the beam combiner **1103** may be a zinc selenide (ZnSe), zinc sulfide (ZnS), or germanium (Ge) beam combiner. For example, the beam combiner **1103** may be configured to transmit infrared light and reflect visible light. In some embodiments, the beam combiner **1103** may be a dichroic. In some embodiments, the beam combiner **1103** may be configured to pass electromagnetic radiation having a wavelength longer than a cutoff wavelength and reflect electromagnetic radiation having a wavelength shorter than the cutoff wavelength. In some embodiments, the beam combiner may be configured to pass electromagnetic radiation having a wavelength shorter than a cutoff wavelength and reflect electromagnetic radiation having a wavelength longer than the cutoff wavelength. In some embodiments, the beam combiner may be a polarizing beam splitter, a long pass filter, a short pass filter, or a band pass filter.

[0097] An optical control system of the present disclosure may further comprise a lens positioned in the optical path. In some embodiments, a lens may be a focusing lens positioned such that the focusing lens focuses the beam, the scattered light, or both. For example, a focusing lens may be positioned in the visible light path to focus the scattered light onto the

targeting camera. In some embodiments, a lens may be a defocusing lens positioned such that the defocusing lens defocuses the beam, the scattered light, or both. In some embodiments, the lens may be a collimating lens positioned such that the collimating lens collimates the beam, the scattered light, or both. In some embodiments, two or more lenses may be positioned in the optical path. For example, two lenses may be positioned in the optical path in series to expand or narrow the beam.

[0098] The positions and orientations of one or both of the first reflective element **1105** and the second reflective element **1106** may be controlled by actuators. In some embodiments, an actuator may be a motor, a solenoid, a galvanometer, or a servo. For example, the position of the first reflective element **1105** may be controlled by a first actuator, and the position and orientation of the second reflective element **1106** may be controlled by a second actuator. In some embodiments, a single reflective element may be controlled by a plurality of actuators. For example, the first reflective element **1105** may be controlled by a first actuator along a first axis and a second actuator along a second axis. In some embodiments, a single actuator may control a reflective element along a plurality of axes.

[0099] An actuator may change a position of a reflective element by rotating the reflective element, thereby changing an angle of incidence of a beam encountering the reflective element. Changing the angle of incidence may cause a translation of the position at which the beam encounters the surface. In some embodiments, the angle of incidence may be adjusted such that the position at which the beam encounters the surface is maintained while the optical system moves with respect to the surface. An actuator may be servo-controlled, piezoelectric actuated, piezo inertial actuated, stepper motor-controlled, galvanometer-driven, linear actuator-controlled, or any combination thereof. A reflective element may be a mirror; for example, a dichroic mirror, or a dielectric mirror; a prism; a beam splitter; or any combination thereof. In some embodiments, a reflective element may be any element capable of deflecting the beam.

[0100] **FIG. 11B** shows a top view of an embodiment of a detection system **101** as shown in **FIG. 11A**. As seen in **FIG. 11A**, the camera **1104** may be positioned to capture light, for example visible light, traveling along a visible light path **1152** in a direction opposite the beam path, for example laser path **1102**. The light may be scattered by a surface, such as the surface with an object of interest, or an object, such as an object of interest, and travel toward the targeting camera **1104** along visible light path **1152**. In some embodiments, the camera **1104** is positioned such that it captures light reflected off of the beam combiner **1103**. In other embodiments, the camera **1104** is positioned such that it captures light transmitted through the beam combiner **1103**. With the capture of such light, the camera **1104** may be configured to image a region of interest on a surface. The camera **1104** may be coupled to the beam combiner

1103, or the camera **1104** may be coupled to a support structure supporting the beam combiner **1103**. In one embodiment, the camera **1104** does not move with respect to the beam combiner **1103**, such that the targeting camera **1104** maintains a fixed position relative to the beam combiner **1103**.

[0101] The high intensity illumination systems described herein, or the object targeting systems described herein, may be part of an autonomous weed eradication system to target and eliminate weeds. For example, an autonomous weed eradication system may be used to target a weed of interest identified and/or located in an image or representation collected by a sensor, such as a sensor. Targeting the weed may comprise precisely locating the weed using the sensor, targeting the weed with a laser, and eradicating the weed by burning it with laser light, such as infrared light. The high intensity illumination system may improve the accuracy of the weed targeting by enabling shorter camera frame rates, shorter image exposure times, higher resolution imaging, or combinations thereof.

[0102] A method **1200** of targeting an object using a high intensity illumination system of the present disclosure is illustrated in **FIG. 12**. Such a method may be implemented using a lighting array as described herein, such as lighting array **150** illustrated in **FIG. 5A**, **FIG. 5B**, **FIG. 6A**, or **FIG. 6B**. The object may be detected using a detection system as described herein, such as detection system **101** illustrated in **FIG. 10**. In some embodiments, both the lighting array and the object detection system may be coupled to a vehicle, such as an autonomous weed eradication vehicle, as illustrated in **FIG. 1A**, **FIG. 1B**, and **FIG. 1C** to detect an object **161** (e.g., a weed) located on a surface **160** (e.g., the ground). At step **1210** of method **1200**, the lighting array may be activated. Upon activation, the lighting array may illuminate a region of interest on the surface with high intensity illumination. At step **1220**, the detection system may begin collecting an image of a region of interest illuminated by the lighting array. Beginning image collection and activation of the lighting array may happen substantially simultaneously. In some embodiments, activating the lighting array and beginning image collection may happen within about 0.1 μ s, about 1 μ s, about 10 μ s, or about 0.1 ms of each other. In some embodiments, activation of the lighting array may occur before beginning image collection. Activation of the lighting array may occur no more than about 0.1 μ s, about 1 μ s, about 10 μ s, or about 0.1 ms before beginning image collection. In some embodiments, beginning image collection may occur before activation of the lighting array. Beginning image collection may occur no more than about 0.1 μ s, about 1 μ s, about 10 μ s, or about 0.1 ms before activation of the lighting array.

[0103] An image of the region of interest may be collected at step **1230** to produce an image of the region of interest. Image collection may correspond to a period of time between beginning

image collection and ending image collection, which may be referred to as an exposure time of the image. At step **1240**, the detection system may end image collection of the region of interest, and at step **1250**, the lighting array may be deactivated. Ending image collection and deactivation of the lighting array may happen substantially simultaneously. In some embodiments, deactivating the lighting array and ending image collection may happen within about 0.1 μ s, about 1 μ s, about 10 μ s, or about 0.1 ms of each other. In some embodiments, deactivation of the lighting array may occur before ending image collection. Deactivation of the lighting array may occur no more than about 0.1 μ s, about 1 μ s, about 10 μ s, or about 0.1 ms before ending image collection. In some embodiments, ending image collection may occur before deactivation of the lighting array. Ending image collection may occur no more than about 0.1 μ s, about 1 μ s, about 10 μ s, or about 0.1 ms before deactivation of the lighting array.

[0104] The steps of activating the lighting array (step **1210**), beginning image collection (step **1220**), collecting an image (step **1230**), ending image collection (step **1240**), and deactivating the lighting array (step **1250**) may be repeated to collect a series of images (e.g., a video). The steps may be repeated at a rate corresponding to a frame rate, also referred to as a camera frame rate or a video frame rate. In some embodiments, a frame rate may be measured as a time between beginning collection of consecutive image frames, i.e., a time between beginning collection of a first image frame and beginning collection of a second, subsequent image frame.

[0105] At step **1260** an object, such as object **161** in **FIG. 1C**, may be located in an image collected in step **1230** or in a series of images collected by repeating steps **1210**, **1220**, **1230**, **1240**, and **1250**. Use of the high intensity illumination system may improve the accuracy of object location in the image by improving image quality, such as by providing more even illumination over the region of interest captured in the image, enabling faster frame rates, enabling shorter frame times, enabling higher image resolution, or combinations thereof. The object may be targeted with an implement at step **1270** based on the location determined in step **1260**. For example, the object may be a weed that is targeted with a laser implement to burn the weed. In another example, the object may a plant (e.g., a crop or a weed) that is sprayed with a spraying implement. In another example, the object may be moved with a grabbing implement. In some embodiments, the implement may comprise an array of implements, and targeting the object may comprise selectively activating or inactivating individual implements within the array to target object of interest. For example, an implement may comprise an array of sprayers, and each sprayer in the array is activated or inactivated depending on the location of the object of interest such that the location of an object of interest is selectively sprayed.

[0106] **FIG. 13A** illustrates a system bus architecture of computing system **400**, according to example embodiments. System **400** may be representative of at least a portion of detection

system **101** or control system **700**. For example, system **400** may be representative of at least a portion of computer **701** of control system **700**. One or more components of system **400** may be in electrical communication with each other using a bus **405**. System **400** may include a processing unit (CPU or processor) **410** and a system bus **405** that couples various system components including the system memory **415**, such as read only memory (ROM) **420** and random access memory (RAM) **425**, to processor **410**. System **400** may include a cache of high-speed memory connected directly with, in close proximity to, or integrated as part of processor **410**. System **400** may copy data from memory **415** and/or storage device **430** to cache **412** for quick access by processor **410**. In this way, cache **412** may provide a performance boost that avoids processor **410** delays while waiting for data. These and other modules may control or be configured to control processor **410** to perform various actions. Other system memory **415** may be available for use as well. Memory **415** may include multiple different types of memory with different performance characteristics. Processor **410** may include any general purpose processor and a hardware module or software module, such as service 1 **432**, service 2 **434**, and service 3 **436** stored in storage device **430**, configured to control processor **410** as well as a special-purpose processor where software instructions are incorporated into the actual processor design. Processor **410** may essentially be a completely self-contained computing system, containing multiple cores or processors, a bus, memory controller, cache, etc. A multi-core processor may be symmetric or asymmetric.

[0107] To enable user interaction with the computing system **400**, an input device **445** may represent any number of input mechanisms, such as a microphone for speech, a touch-sensitive screen for gesture or graphical input, keyboard, mouse, motion input, speech and so forth. An output device **435** may also be one or more of a number of output mechanisms known to those of skill in the art. In some instances, multimodal systems may enable a user to provide multiple types of input to communicate with computing system **400**. Communications interface **440** may generally govern and manage the user input and system output. There is no restriction on operating on any particular hardware arrangement and therefore the basic features here may easily be substituted for improved hardware or firmware arrangements as they are developed.

[0108] Storage device **430** may be a non-volatile memory and may be a hard disk or other types of computer readable media which may store data that are accessible by a computer, such as magnetic cassettes, flash memory cards, solid state memory devices, digital versatile disks, cartridges, random access memories (RAMs) **425**, read only memory (ROM) **420**, and hybrids thereof.

[0109] Storage device **430** may include services **432**, **434**, and **436** for controlling the processor **410**. Other hardware or software modules are contemplated. Storage device **430** may be

connected to system bus **405**. In one aspect, a hardware module that performs a particular function may include the software component stored in a computer-readable medium in connection with the necessary hardware components, such as processor **410**, bus **405**, output device **435** (e.g., display), and so forth, to carry out the function.

[0110] **FIG. 13B** illustrates a computer system **450** having a chipset architecture that may represent at least a portion of detection system **140** or control system **700**. For example, system **400** may be representative of at least a portion of computer **701** of control system **700**. Computer system **450** may be an example of computer hardware, software, and firmware that may be used to implement the disclosed technology. System **450** may include a processor **455**, representative of any number of physically and/or logically distinct resources capable of executing software, firmware, and hardware configured to perform identified computations. Processor **455** may communicate with a chipset **460** that may control input to and output from processor **455**. In this example, chipset **460** outputs information to output **465**, such as a display, and may read and write information to storage device **470**, which may include magnetic media, and solid state media, for example. Chipset **460** may also read data from and write data to storage device **475** (e.g., RAM). A bridge **480** for interfacing with a variety of user interface components **485** may be provided for interfacing with chipset **460**. Such user interface components **485** may include a keyboard, a microphone, touch detection and processing circuitry, a pointing device, such as a mouse, and so on. In general, inputs to system **450** may come from any of a variety of sources, machine generated and/or human generated.

[0111] Chipset **460** may also interface with one or more communication interfaces **490** that may have different physical interfaces. Such communication interfaces may include interfaces for wired and wireless local area networks, for broadband wireless networks, as well as personal area networks. Some applications of the methods for generating, displaying, and using the GUI disclosed herein may include receiving ordered datasets over the physical interface or be generated by the machine itself by processor **455** analyzing data stored in storage device **470** or storage device **475**. Further, the machine may receive inputs from a user through user interface components **485** and execute appropriate functions, such as browsing functions by interpreting these inputs using processor **455**.

[0112] It may be appreciated that example systems **400** and **450** may have more than one processor **410** or be part of a group or cluster of computing devices networked together to provide greater processing capability.

[0113] In the foregoing description, aspects of the application are described with reference to specific embodiments thereof, but those skilled in the art will recognize that the application is not limited thereto. Thus, while illustrative embodiments of the application have been described

in detail herein, it is to be understood that the inventive concepts may be otherwise variously embodied and employed, and that the appended claims are intended to be construed to include such variations, except as limited by the prior art. Various features and aspects of the above-described application may be used individually or jointly. Further, embodiments can be utilized in any number of environments and applications beyond those described herein without departing from the broader spirit and scope of the specification. The specification and drawings are, accordingly, to be regarded as illustrative rather than restrictive. For the purposes of illustration, methods were described in a particular order. It should be appreciated that in alternate embodiments, the methods may be performed in a different order than that described.

[0114] One of ordinary skill will appreciate that the less than (“<”) and greater than (“>”) symbols or terminology used herein can be replaced with less than or equal to (“≤”) and greater than or equal to (“≥”) symbols, respectively, without departing from the scope of this description.

[0115] Where components are described as being “configured to” perform certain operations, such configuration can be accomplished, for example, by designing electronic circuits or other hardware to perform the operation, by programming programmable electronic circuits (e.g., microprocessors, or other suitable electronic circuits) to perform the operation, or any combination thereof.

[0116] The phrase “coupled to” refers to any component that is physically connected to another component either directly or indirectly, and/or any component that is in communication with another component (e.g., connected to the other component over a wired or wireless connection, and/or other suitable communication interface) either directly or indirectly.

[0117] Claim language or other language reciting “at least one of” a set and/or “one or more” of a set indicates that one member of the set or multiple members of the set (in any combination) satisfy the claim. For example, claim language reciting “at least one of A and B” means A, B, or A and B. In another example, claim language reciting “at least one of A, B, and C” means A, B, C, or A and B, or A and C, or B and C, or A and B and C. The language “at least one of” a set and/or “one or more” of a set does not limit the set to the items listed in the set. For example, claim language reciting “at least one of A and B” can mean A, B, or A and B, and can additionally include items not listed in the set of A and B.

[0118] As used herein, the terms “about” and “approximately,” in reference to a number, is used herein to include numbers that fall within a range of 10%, 5%, or 1% in either direction (greater than or less than) the number unless otherwise stated or otherwise evident from the context (except where such number would exceed 100% of a possible value).

[0118a] The term ‘comprise’ and variants of the term such as ‘comprises’ or ‘comprising’ are used herein to denote the inclusion of a stated integer or stated integers but not to exclude any other integer or any other integers, unless in the context or usage an exclusive interpretation of the term is required.

EXAMPLES

[0119] The invention is further illustrated by the following non-limiting examples.

EXAMPLE 1

High Intensity Illumination of a Crop Field

[0120] This example describes high intensity illumination of a crop field for autonomous weed detection. An autonomous vehicle, as illustrated in **FIG. 1A** and **FIG. 1B**, equipped with a high intensity illumination system and a detection system, was positioned in a field of crops. The autonomous vehicle navigated the rows of crops, while the high intensity illumination system illuminated a region of interest of the field beneath the vehicle, and the detection system imaged the region of interest. The high intensity illumination system illuminated the region of interest with an array of light emitters, such as light emitting diodes (LEDs), arranged to provide uniform brightness across the region of interest. A voltage of 92 V was applied to each of the LEDs, such that the high intensity illumination system illuminated the region of interest with approximately 600,000 lumens per m² (lux). The applied voltage was well above the maximum voltage of 69.4 V at which the LEDs were designed to operate. To avoid overheating due to high voltage, the LEDs operated with a duty cycle of 7%. The on/off state of the LEDs was synchronized to a camera exposure of the detection system, such that the LEDs were on while the camera was exposing and off while the camera was not exposing. The camera imaged a region of the field that was approximately 0.58 m² at a resolution of 200 pixels per inch (78.7 pixels per cm), an exposure time of 300 μs, and a depth of field of approximately 5 inches (12.7 cm). The vehicle was traveling at a speed of 0.5 mph (0.224 m/s) while imaging. As seen in the example images provided in **FIG. 2**, plants were clearly identifiable in the captured images, and there were no regions of oversaturation or undersaturation. Images were collected at night and during various times throughout the day without noticeable changes in illumination.

[0121] In contrast, a similar autonomous vehicle without the high intensity illumination system was used to image a region of interest of a field of crops. The autonomous vehicle without the high intensity illumination system included protective shrouds surrounding the imaging system to block stray light from the sun. Example images, collected without a high intensity illumination system while the autonomous vehicle was stationary, are shown in **FIG. 3**. Even with the light-blocking shroud, stray light reached the surface within the region of interest,

causing uneven illumination and oversaturation of sections of the images. Oversaturated sections caused by stray light glare are denoted by arrows in **FIG. 3**. Glare from stray light was particularly problematic for the autonomous vehicle without the high intensity illumination system at times when the sun was at a low angle (e.g., shortly after sunrise or shortly before sunset).

EXAMPLE 2

Reduction of Motion Blurring Using a High Intensity Illumination System

[0122] This example describes reduction of motion blurring using a high intensity illumination system. Illuminating a region of interest with high intensity illumination reduces motion blurring that results from movement of the camera relative to the region of interest during the frame exposure time. A camera positioned on a vehicle moving along a surface at 2 miles per hour (0.894 m/s) images regions of the surface. Under standard illumination conditions (approximately 60,000 lux), the camera exposure time is set to 3 ms to capture sufficient light for high resolution (200 pixels per inch) imaging. The resulting images contains substantial motion blurring due to the movement of the vehicle during the relatively long 3 ms exposure time. An image simulating 3 ms exposure time with 60,000 lux illumination is shown in **FIG. 4C**. The vehicle moves approximately 2.68 mm relative to the surface during the 3 ms exposure. As seen in **FIG. 4C**, the motion blurring obscures detection of objects, such as weeds, within the image.

[0123] Images are collected from a vehicle moving at 2 miles per hour equipped with an illumination system. With illumination comparable to bright daylight conditions (approximately 120,000 lux), the camera exposure time is set to 1.5 ms to capture sufficient light for high resolution (200 pixels per inch) imaging. The resulting images contain some motion blurring, but substantially less blurring than images captured under 60,000 lux with 3 ms exposure. An image simulating 1.5 ms exposure time with 120,000 lux illumination is shown in **FIG. 4B**. The vehicle moves approximately 1.34 mm relative to the surface during the 1.5 ms exposure. Some blurring is still visible in **FIG. 4B**, but objects, such as weeds, can be detected within the image.

[0124] Finally, images are collected from a vehicle moving at 2 miles per hour equipped with a high intensity illumination system. With illumination comparable to five times the brightness of the sun (approximately 600,000 lux), the camera exposure time is set to 0.3 ms (300 μ s) to capture sufficient light for high resolution (200 pixels per inch) imaging. The resulting images contain almost no detectable motion blurring. An image collected at 0.3 ms exposure time with 600,000 lux illumination is shown in **FIG. 4A**. The vehicle moves only 0.27 mm relative to the surface

during the 0.3 ms exposure. As seen in **FIG. 4A**, objects, such as weeds, can be detected and identified within the image.

EXAMPLE 3

Light Emitting Diode Arrays

[0125] This example describes light emitting diode (LED) arrays configured to produce uniform illumination across a region of interest on a surface. The LEDs are arranged on the underside of an autonomous vehicle, as shown in **FIG. 5B** and **FIG. 6B**, and are configured to illuminate the surface beneath the vehicle as the vehicle travels over the surface and collects images of regions of interest. Examples of LED arrays configured to produce uniform illumination on a surface are shown in **FIG. 5A** and **FIG. 6A**. A vehicle may be equipped with multiple LED arrays. The LED arrangement is tailored to produce even illumination of a surface of interest, such as a field with rows of crops. The LED arrangement is determined using a computer simulation to minimize variations in the sum of the intensity from a plurality of LEDs across a region of interest of the surface. The computer simulation considers parameters including the number of LEDs, presence and type of reflectors, geometric constraints of a device on which the lighting arrays are positioned, distance from the surface, and field of view of a camera positioned to image the region of interest. The computer simulation varies parameters including position of LEDs, number of LEDs, angle of LEDs, inclusion of reflectors, and type of reflectors.

EXAMPLE 4

Electrical Configuration of a High Intensity Illumination System

[0126] This example describes an electrical configuration of a high intensity illumination system. The high intensity illumination system includes a light emitting diode (LED) array and one or more cameras. The LED array and the cameras are controlled by a strobe printed circuit board (PCB), as shown in **FIG. 7**, which is operated by a computer. The strobe PCB provides a strobe signal to the LED array to turn the LEDs on and off. The on/off state of the LEDs is synchronized with the camera trigger such that the LEDs are on while the camera is collecting data and/or exposing an image. The strobe PCB is designed to provide a voltage to the LEDs that is approximately double the designed operating voltage of the LEDs. The higher than recommended voltage enables the LED array to produce an illuminance of 600,000 lumens per m² (lux), approximately five times as bright as the sun during peak daylight on a sunny day. To prevent overheating as a result of the high voltage, the LEDs are operated with a duty ratio of 7%. A heat sink is added to the LEDs to further prevent overheating.

[0127] While preferred embodiments of the present invention have been shown and described herein, it will be apparent to those skilled in the art that such embodiments are provided by way

of example only. Numerous variations, changes, and substitutions will now occur to those skilled in the art without departing from the invention. It should be understood that various alternatives to the embodiments of the invention described herein may be employed in practicing the invention. It is intended that the following claims define the scope of the invention and that methods and structures within the scope of these claims and their equivalents be covered thereby.

CLAIMS

WHAT IS CLAIMED IS:

1. A system for illuminating and targeting a target, the target being a plant in a field, the system comprising:
 - a lighting array comprising a plurality of lights, wherein the lighting array is configured to evenly illuminate a region of interest in the field, and wherein the region of interest includes the plant; and
 - a detection system comprising:
 - a camera configured to obtain an image of the region of interest, wherein the image depicts the plant,
 - one or more processors configured to determine a target location of the plant in the region of interest based on the image of the region of interest obtained by the camera, and
 - an implement configured to manipulate the plant at the target location.
2. The system of claim 1, wherein the system is, or is configured to be, coupled to a vehicle, and wherein the vehicle is configured to move relative to the field.
3. The system of claim 2, wherein the detection system is, or is configured to be, coupled to the vehicle such that the region of interest imaged by the camera is underneath the vehicle.
4. The system of claim 2 or 3, wherein the lighting array is, or is configured to be, coupled to the vehicle such that the region of interest illuminated by the lighting array is underneath the vehicle.
5. The system of any one of claims 1 to 4, wherein the plant is a weed.
6. The system of any one of claims 1 to 5, wherein the one or more processors are configured to determine the target location of the plant by inputting the image of the region of interest into a deep learning neural network.
7. The system of claim 6, wherein the deep learning neural network is trained to differentiate between crops and weeds.
8. A system for illuminating and targeting weeds in a field, wherein the system is moveable over the field, the system comprising:
 - a camera configured to obtain images of a region of interest in the field;

a lighting array comprising a plurality of lights, wherein the lighting array is configured to evenly illuminate the region of interest in the field;

an implement; and

one or more processors configured to:

activate the lighting array to evenly illuminate the region of interest,
obtain an image of the region of interest from the camera while the region of interest is evenly illuminated,
identify a weed in the image of the region of interest using a neural network configured to differentiate between weeds and crops,
determine a target location of the weed in the region of interest, and
cause the implement to manipulate the weed at the target location.

9. The system of claim 1 to 8, wherein the plurality of lights includes light emitting diodes (LEDs).
10. The system of any one of claims 1 to 9, wherein the illumination from the lighting array is oriented downward toward the region of interest.
11. The system of any one of claims 1 to 10, wherein the lighting array is configured to produce an illumination brightness within the region of interest that varies by no more than 50% across the region of interest.
12. The system of any one of claims 1 to 11, wherein the lighting array is configured to produce an illuminance within the region of interest of at least 120,000 lumens per m² (lux).
13. The system of any one of claims 1 to 12, wherein the lighting array is configured to produce an illuminance of not less than 200,000 lux and not more than 700,000 lux.
14. The system of any one of claims 1 to 13, wherein the system is configured to move over the field while the camera is obtaining the image of the region of interest, and wherein the illumination from the lighting array is configured to reduce or eliminate motion blurring in the image.
15. The system of any one of claims 1 to 14, wherein the illumination from the lighting array is configured to reduce or eliminate variations in illuminance within the region of interest due to variable ambient light.

16. The system of any one of claims 6 to 15, wherein the neural network comprises a convolutional neural network that is trained on images of weeds and crops.
17. The system of any one of claims 1 to 16, wherein activation and deactivation of the lighting array is synchronized to an exposure time of the camera.
18. The system of claim 17, wherein the lighting array is activated when the exposure time of the camera begins and is deactivated when the exposure time of the camera ends.
19. The system of claims 1 to 18, further comprising a strobe circuit configured to activate and deactivate the lighting array.
20. The system of claim 19, wherein the strobe circuit further comprises a capacitor, and wherein the capacitor is configured to charge while the lighting array is deactivated.
21. The system of claim 20, wherein discharging of the capacitor is configured to activate the lighting array.
22. The system of any one of claims 19 to 21, wherein the strobe circuit is configured to activate and deactivate the lighting array with a duty ratio of no more than 15%.
23. The system of any one of claims 1 to 22, further comprising a heat sink configured to dissipate heat from the lighting array.
24. The system of any one of claims 1 to 23, wherein the implement includes an emitter configured to emit a light beam toward the target for eradicating the target.
25. The system of claim 24, wherein the light beam is a laser beam.
26. The system of any one of claims 1 to 25, wherein the implement is configured to burn the target.
27. The system of claim 25 or 26, wherein the light source comprises a control system configured to direct a path of the laser beam, the control system comprising:
a first actuator and a first mirror, and
a second actuator and a second mirror,
wherein the operations further comprise directing the path of the laser beam toward the target location using the control system.

28. The system of any one of claim 1 to 27, wherein the lighting array is configured to evenly illuminate the region of interest such that the image of the region of interest is not overexposed or underexposed due to shadows.
29. The system of any one of claims 1 to 28, wherein the lighting array is configured to evenly illuminate the region of interest in the field without shadowing across the region of interest.

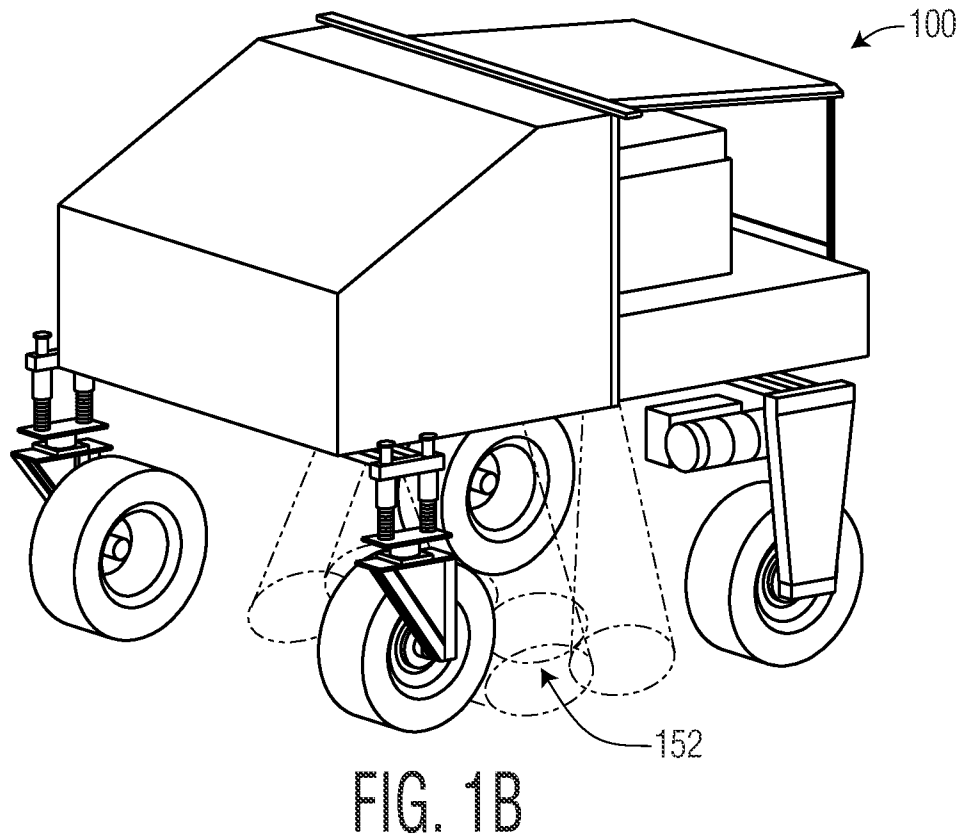
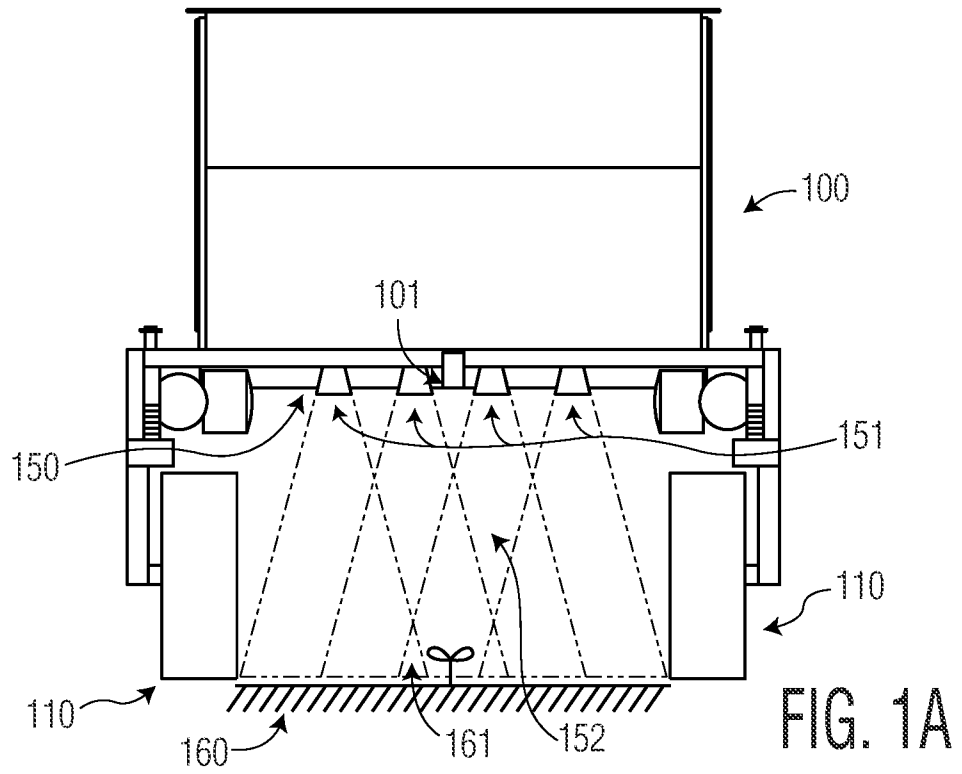

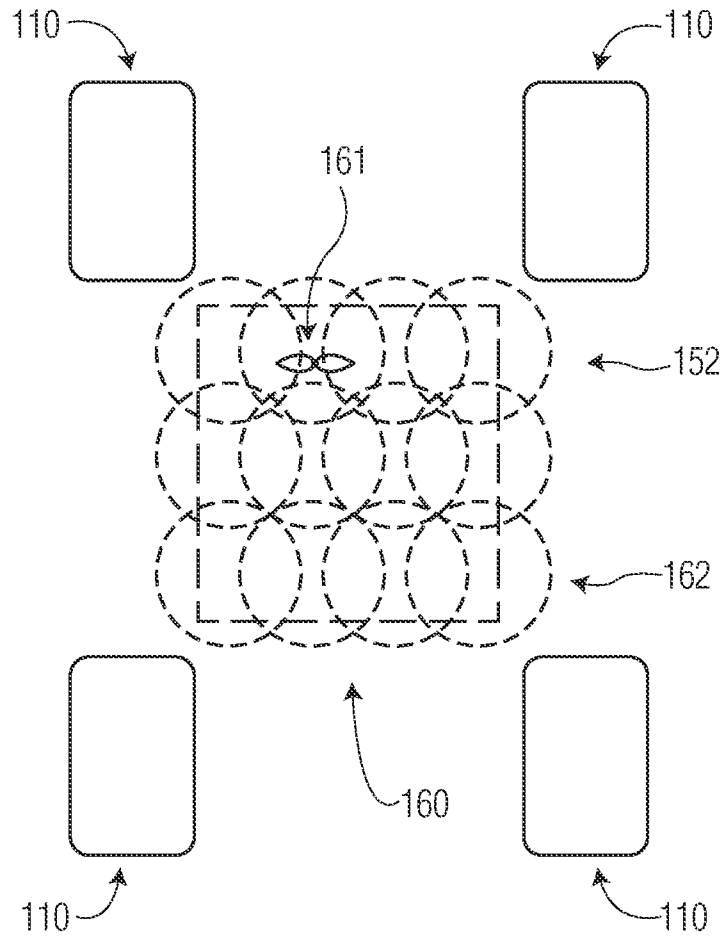

FIG. 1C

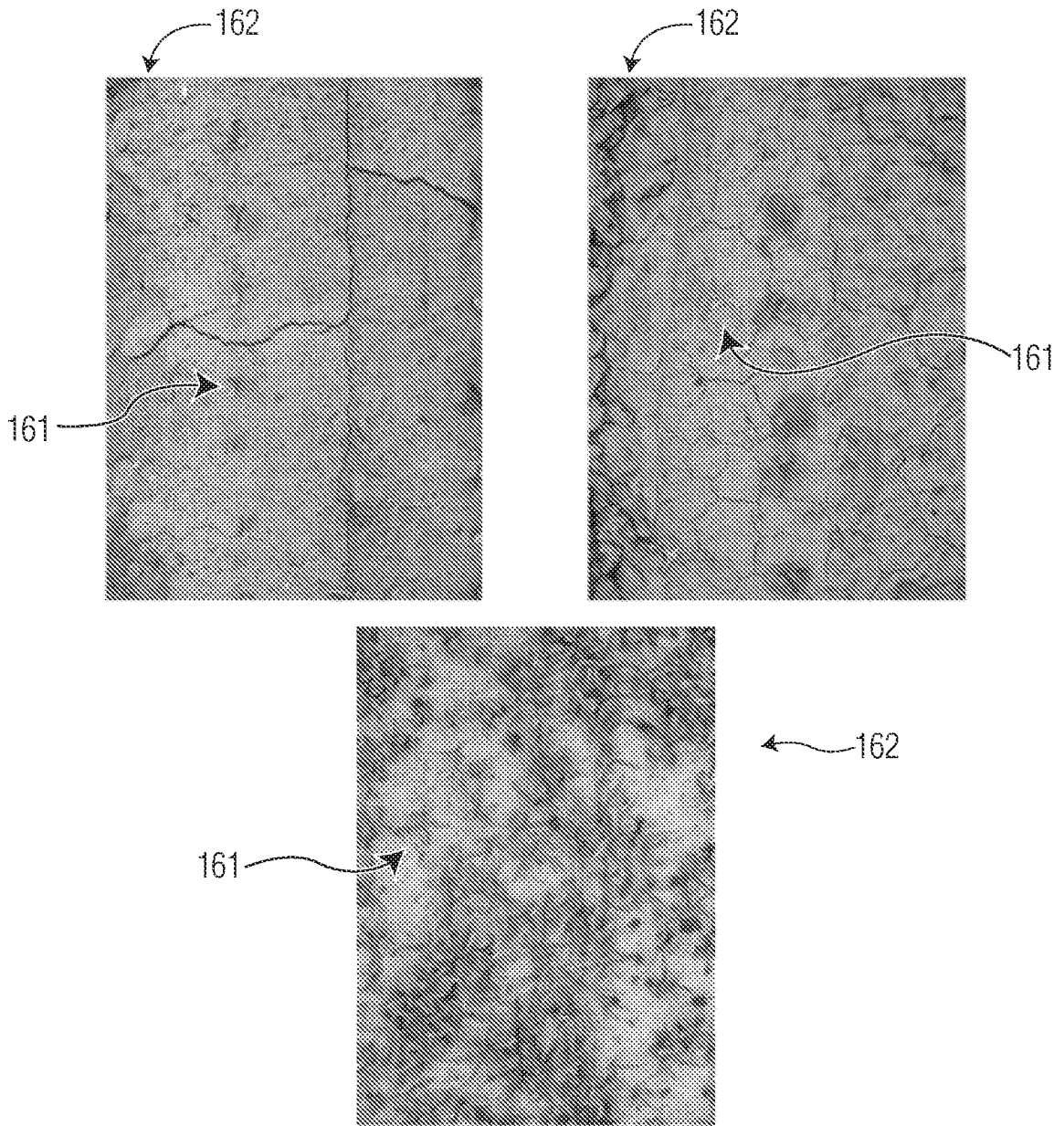

FIG. 2

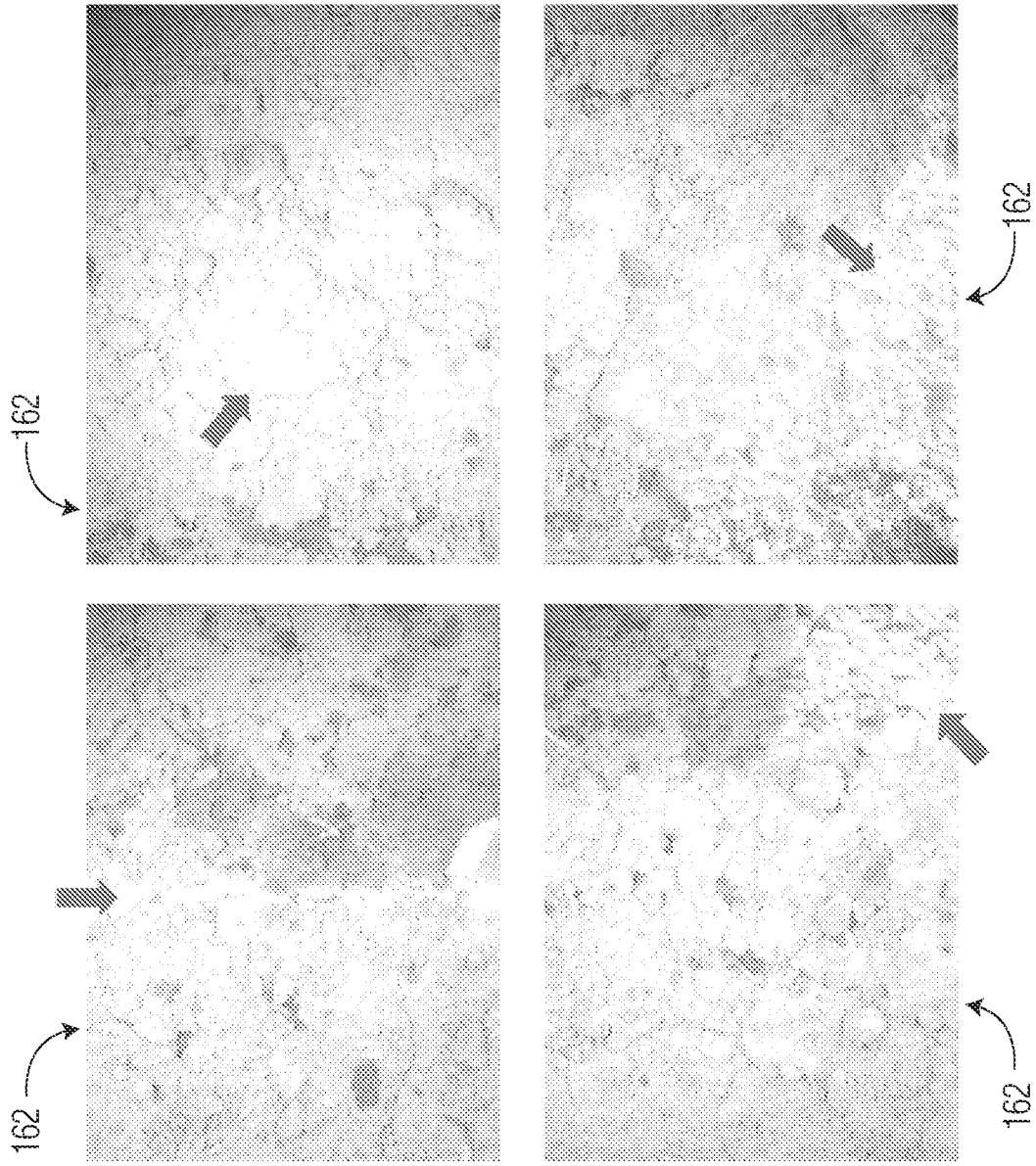

FIG. 3

600,000 lux; 0.3 ms EXPOSURE

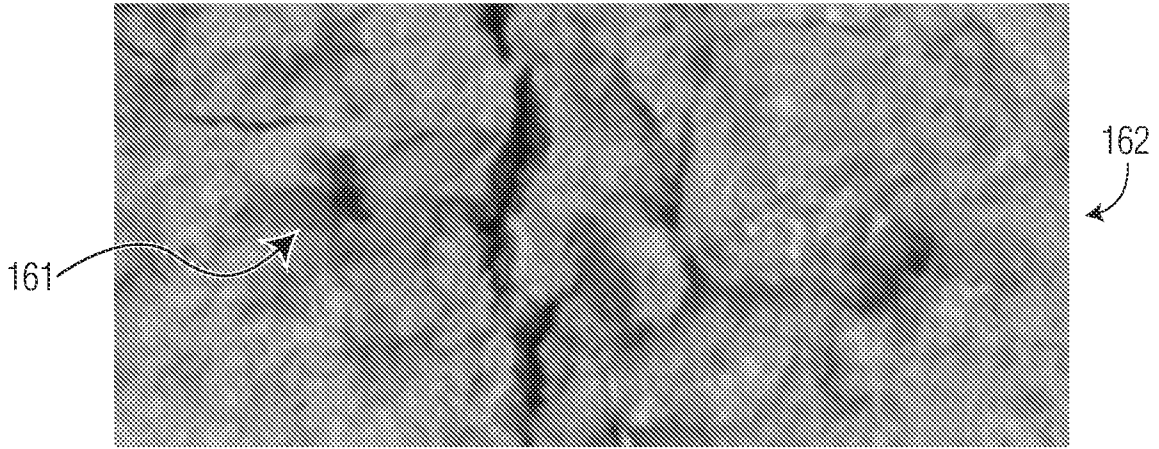

FIG. 4A

120,000 lux; 1.5 ms EXPOSURE

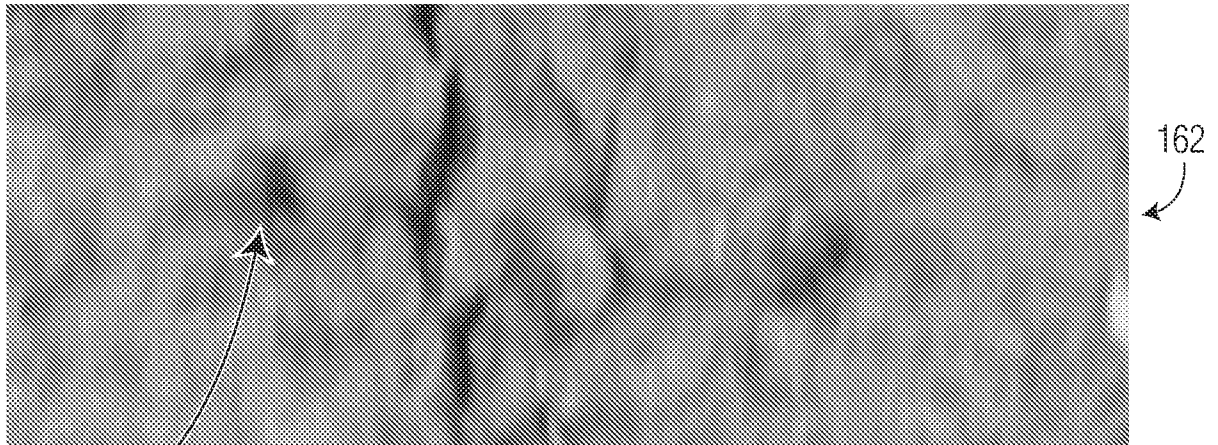

FIG. 4B

60,000 lux; 3 ms EXPOSURE

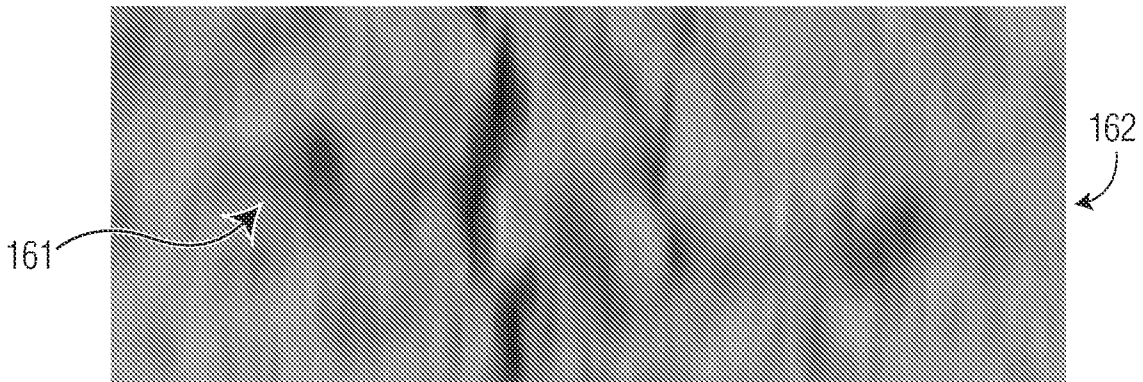

FIG. 4C

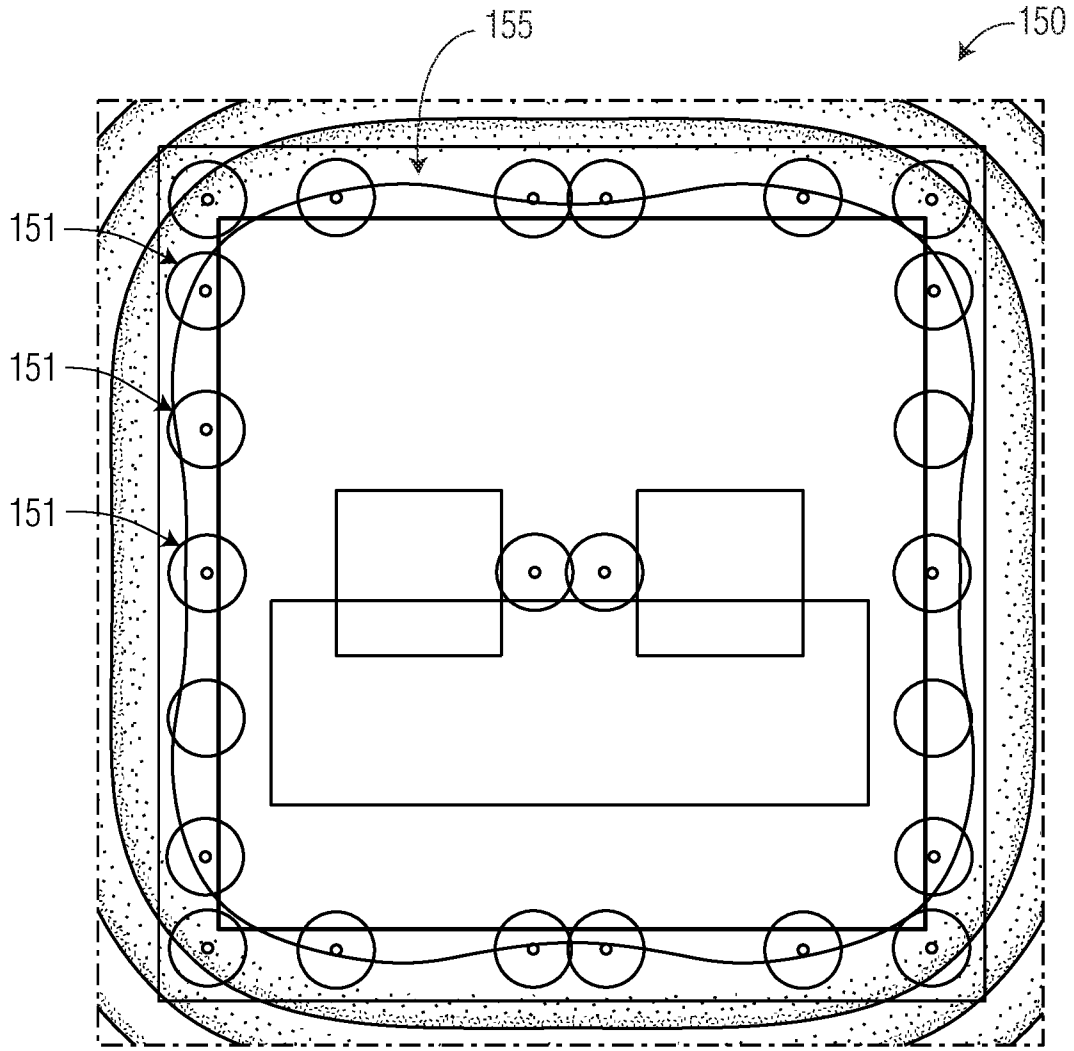

FIG. 5A

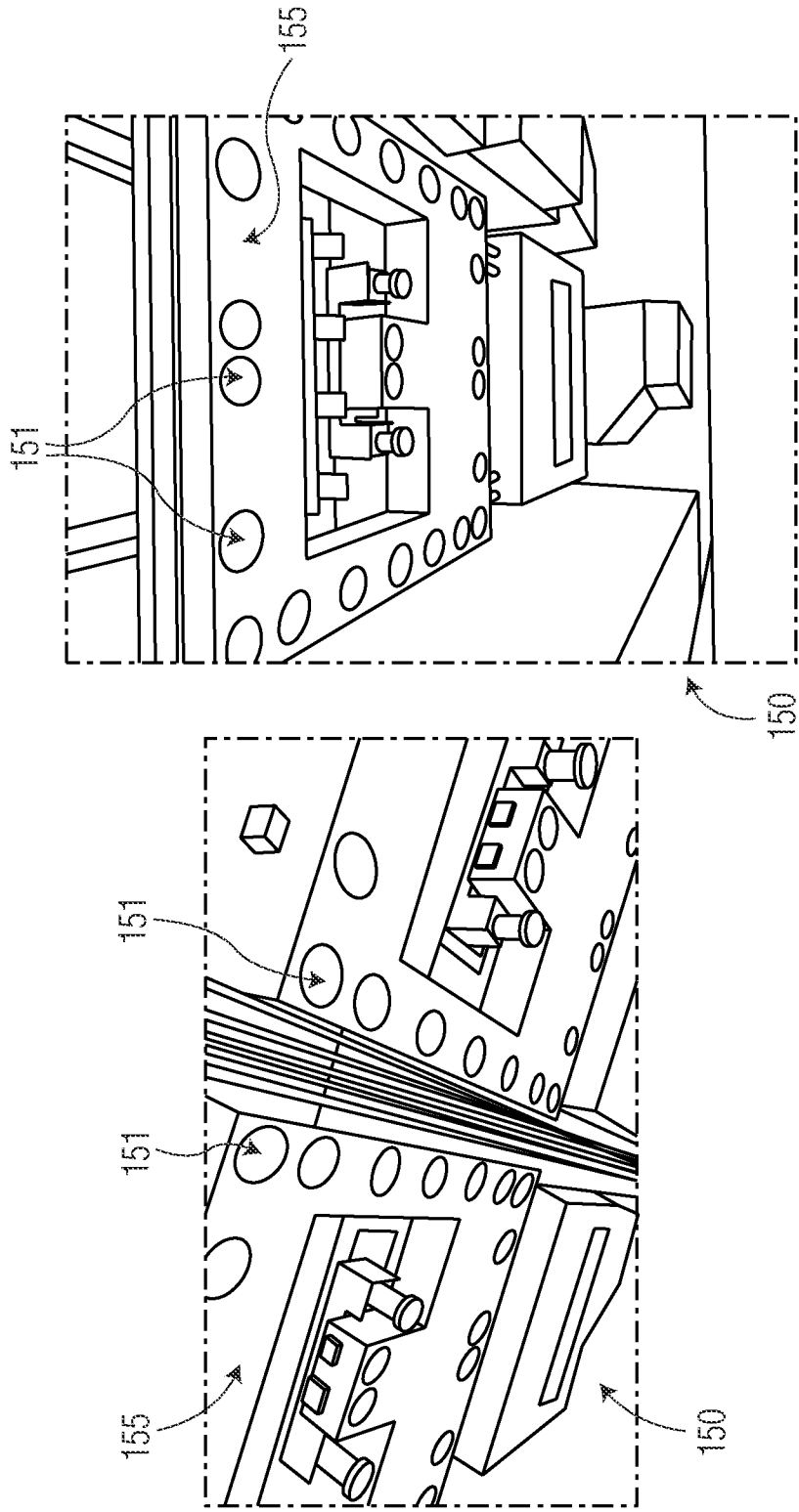

FIG. 5B

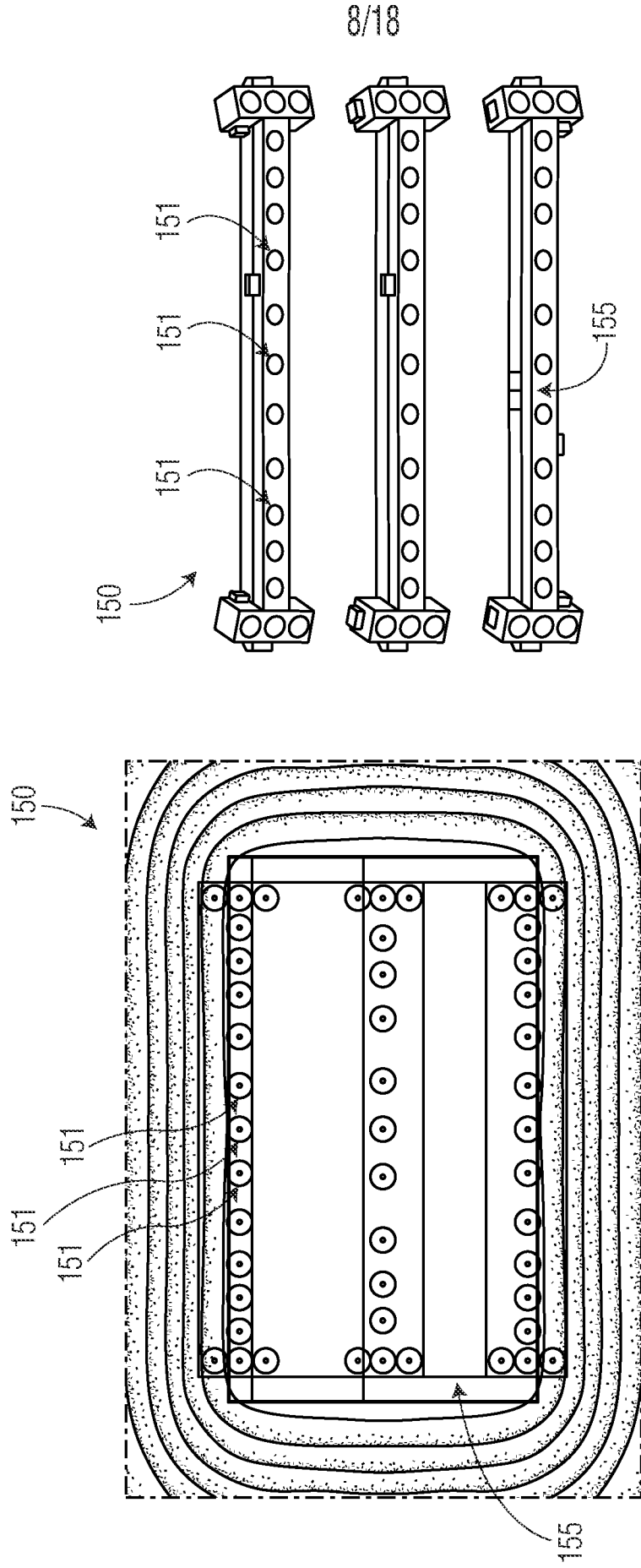

FIG. 6A

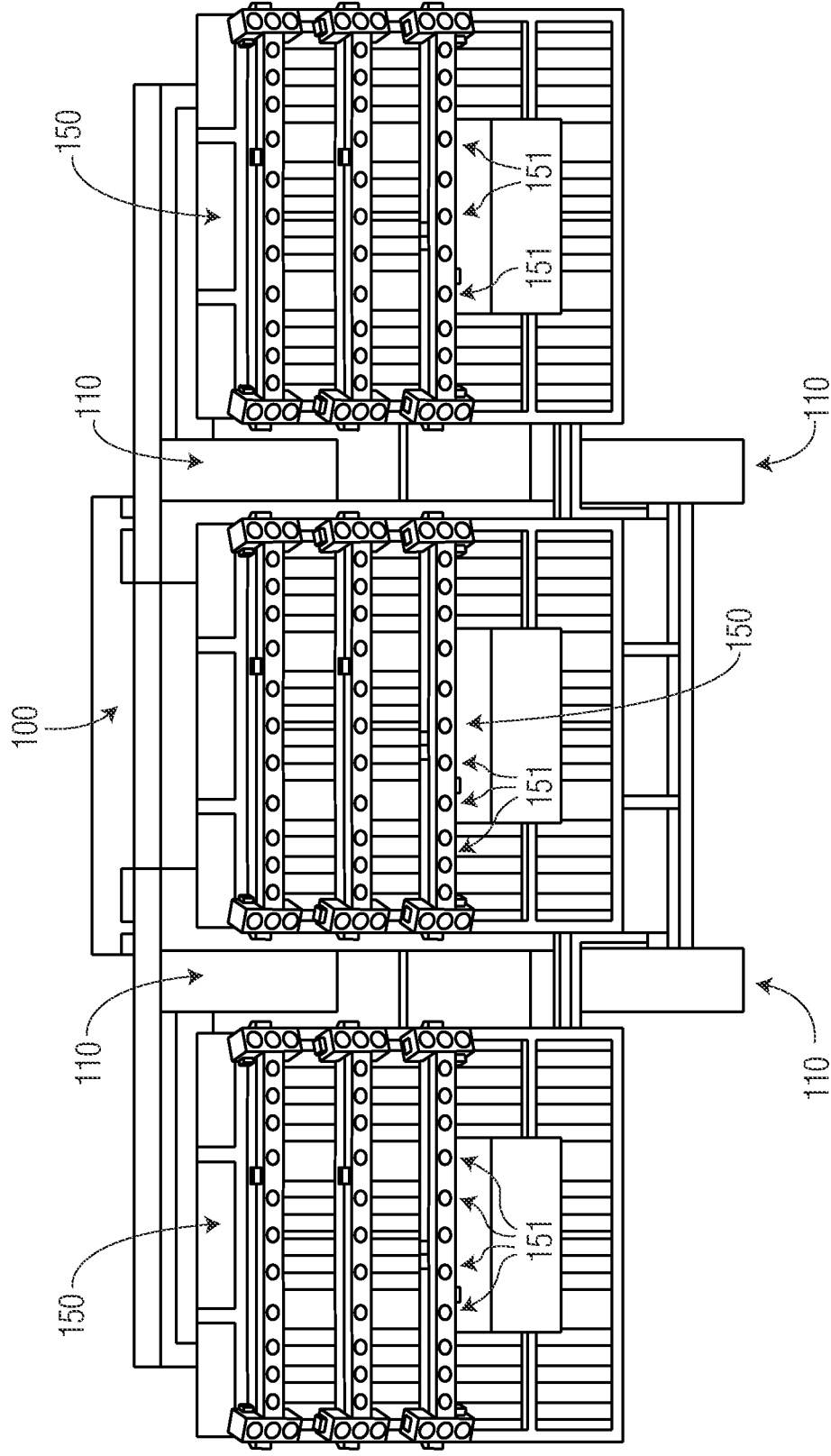

FIG. 6B

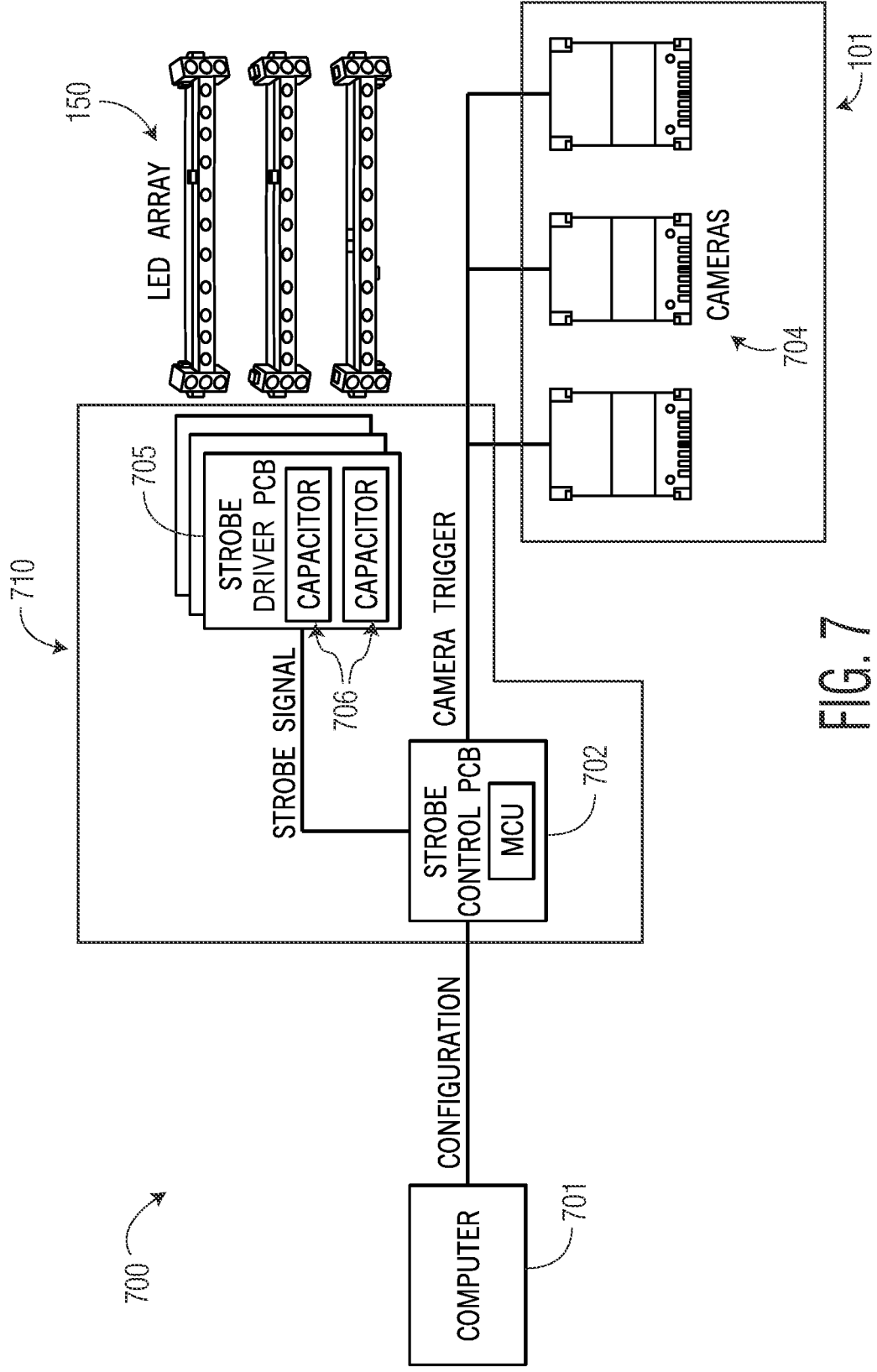

FIG. 7

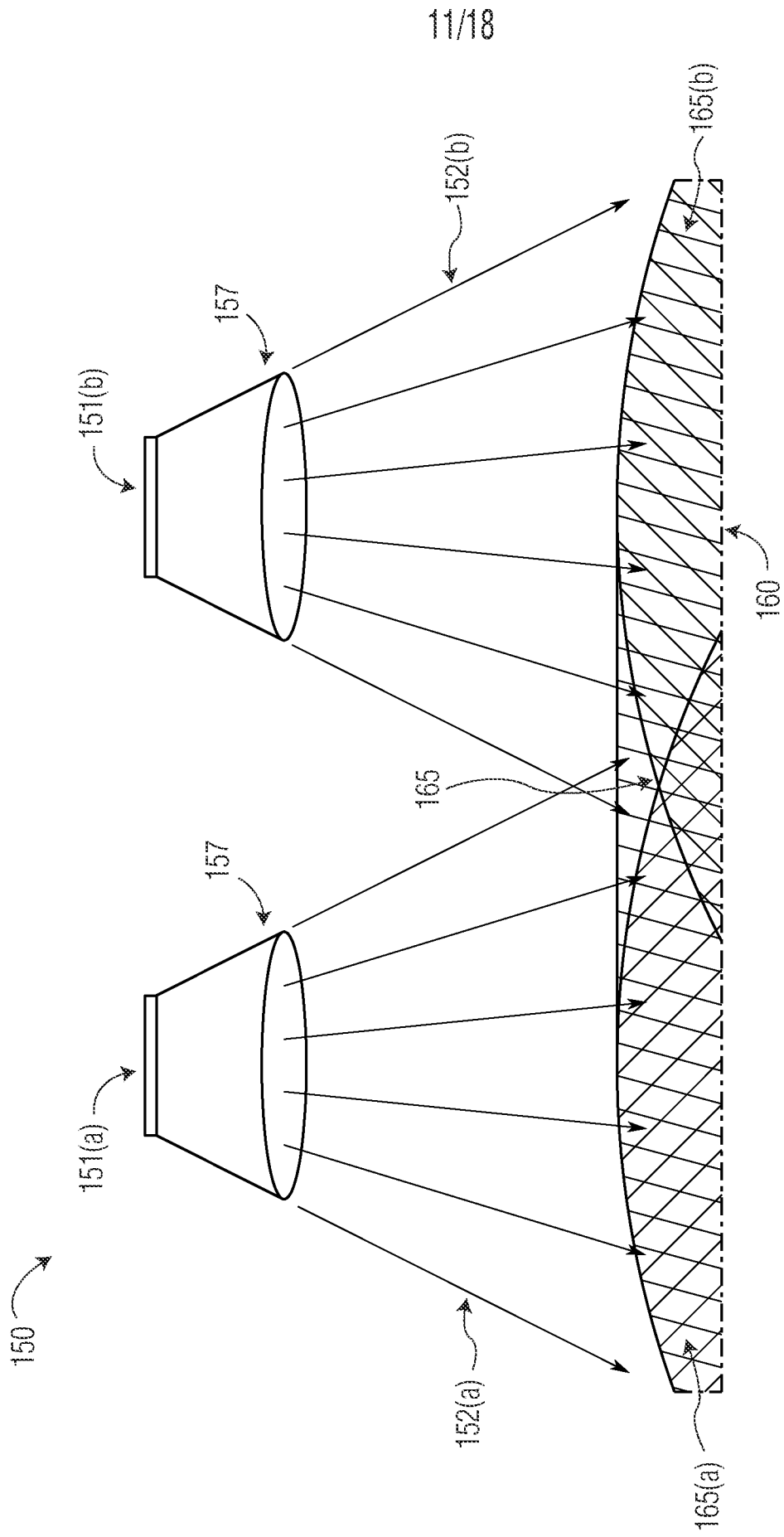

FIG. 8

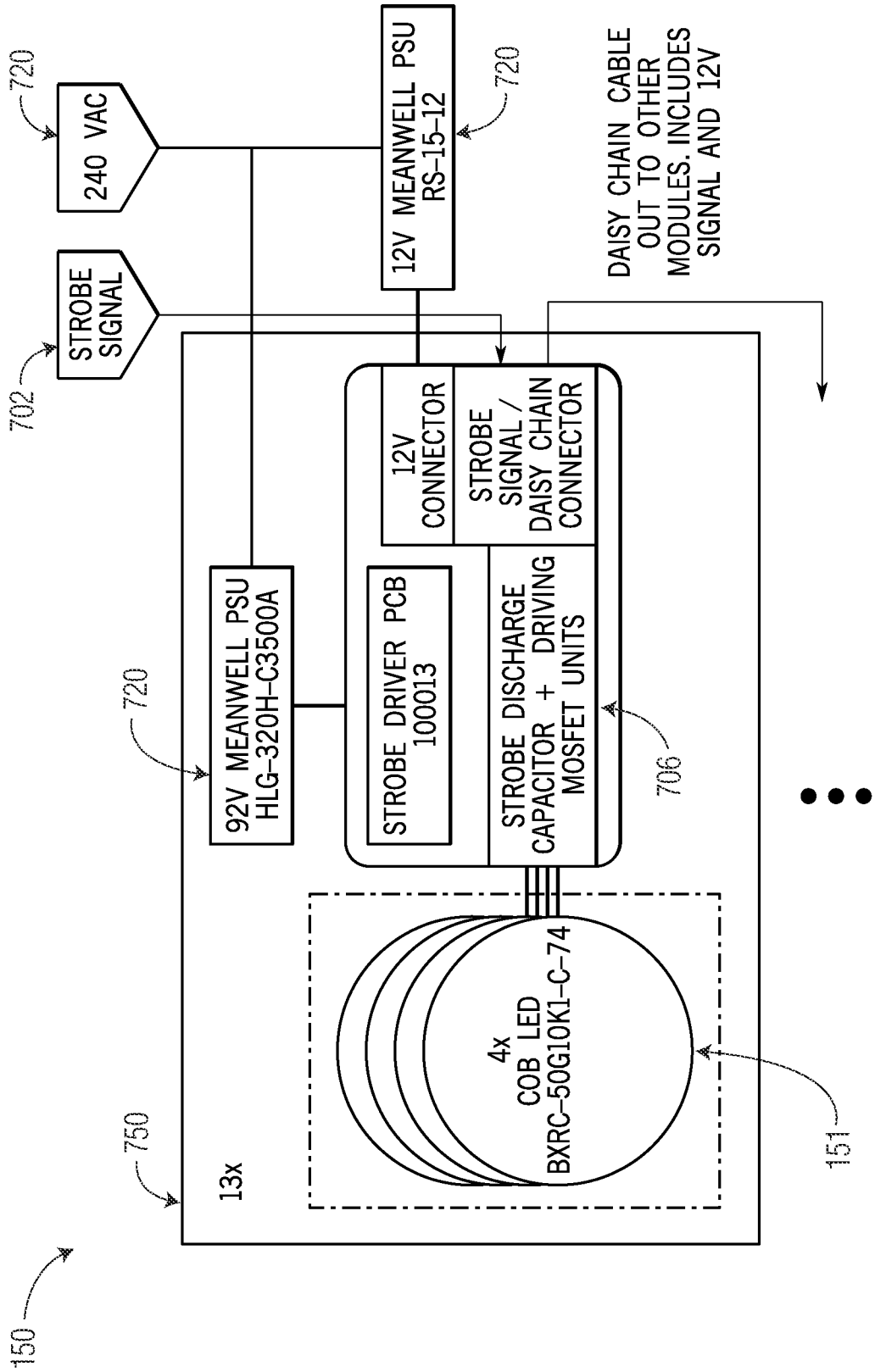

FIG. 9

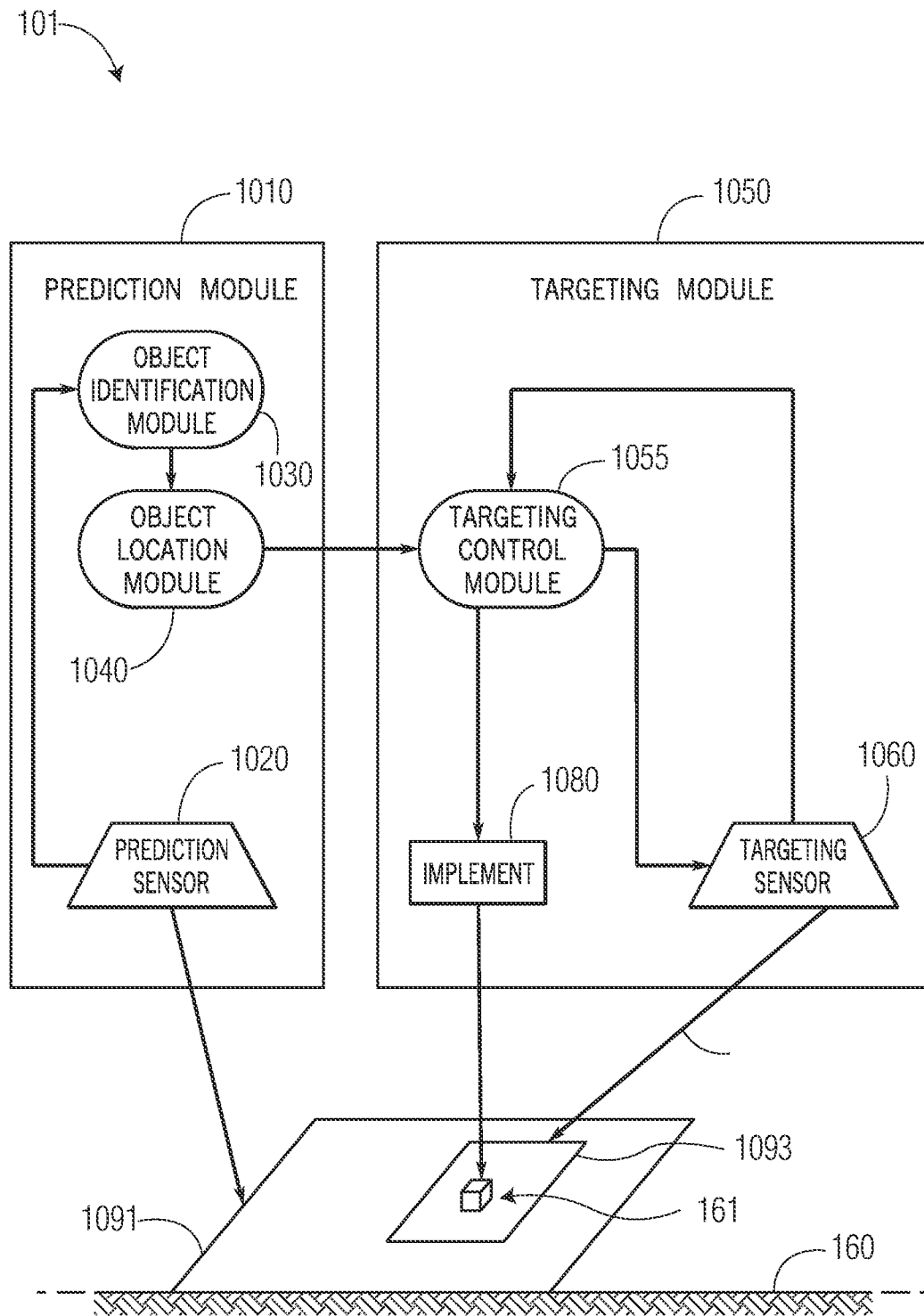

FIG. 10

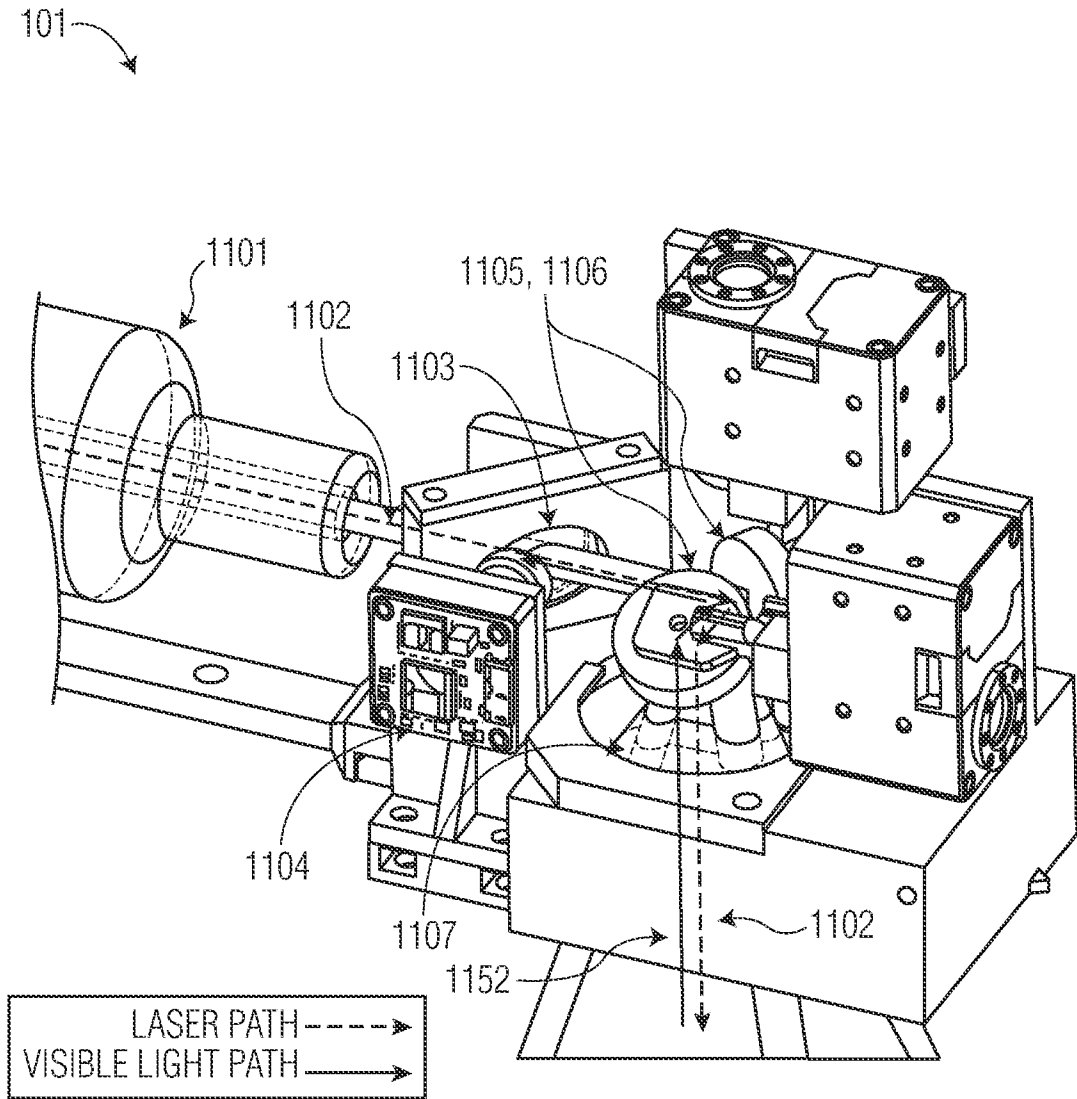

FIG. 11A

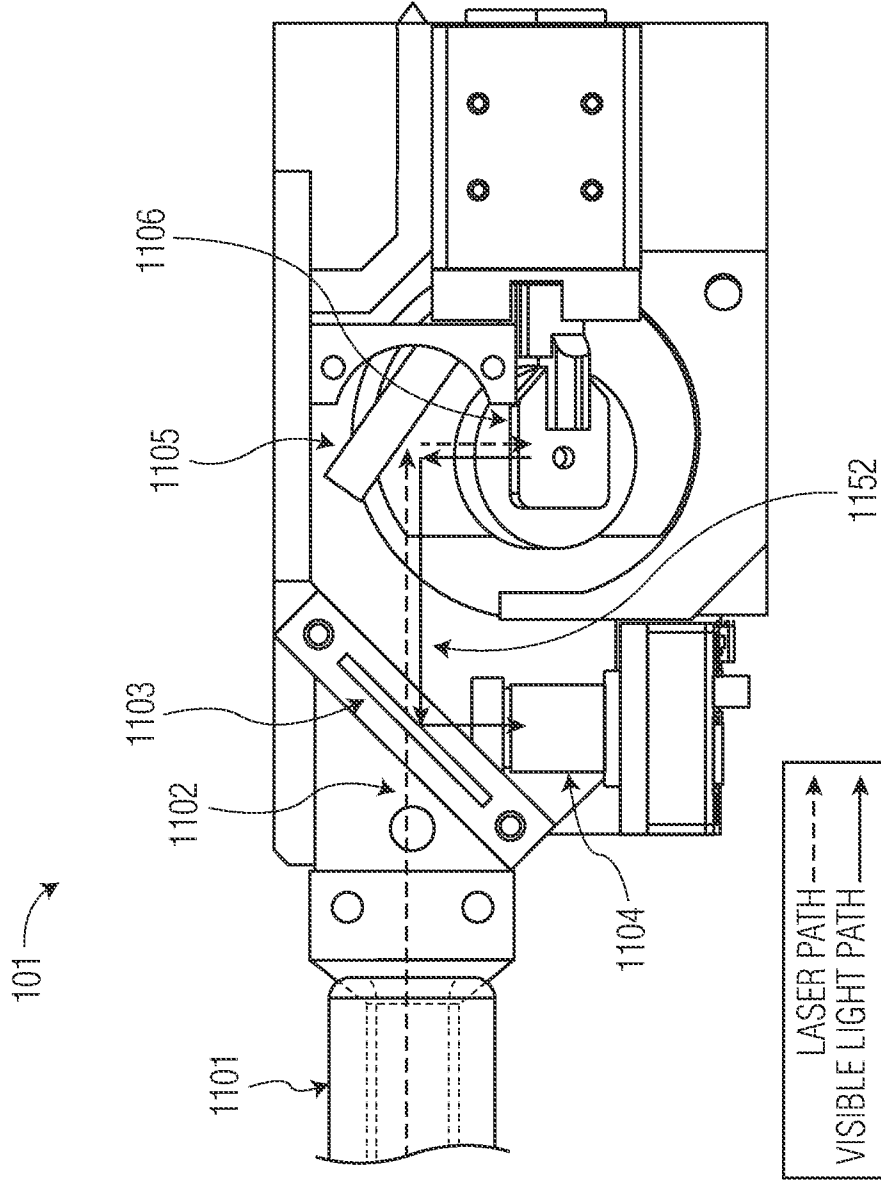

FIG. 11B

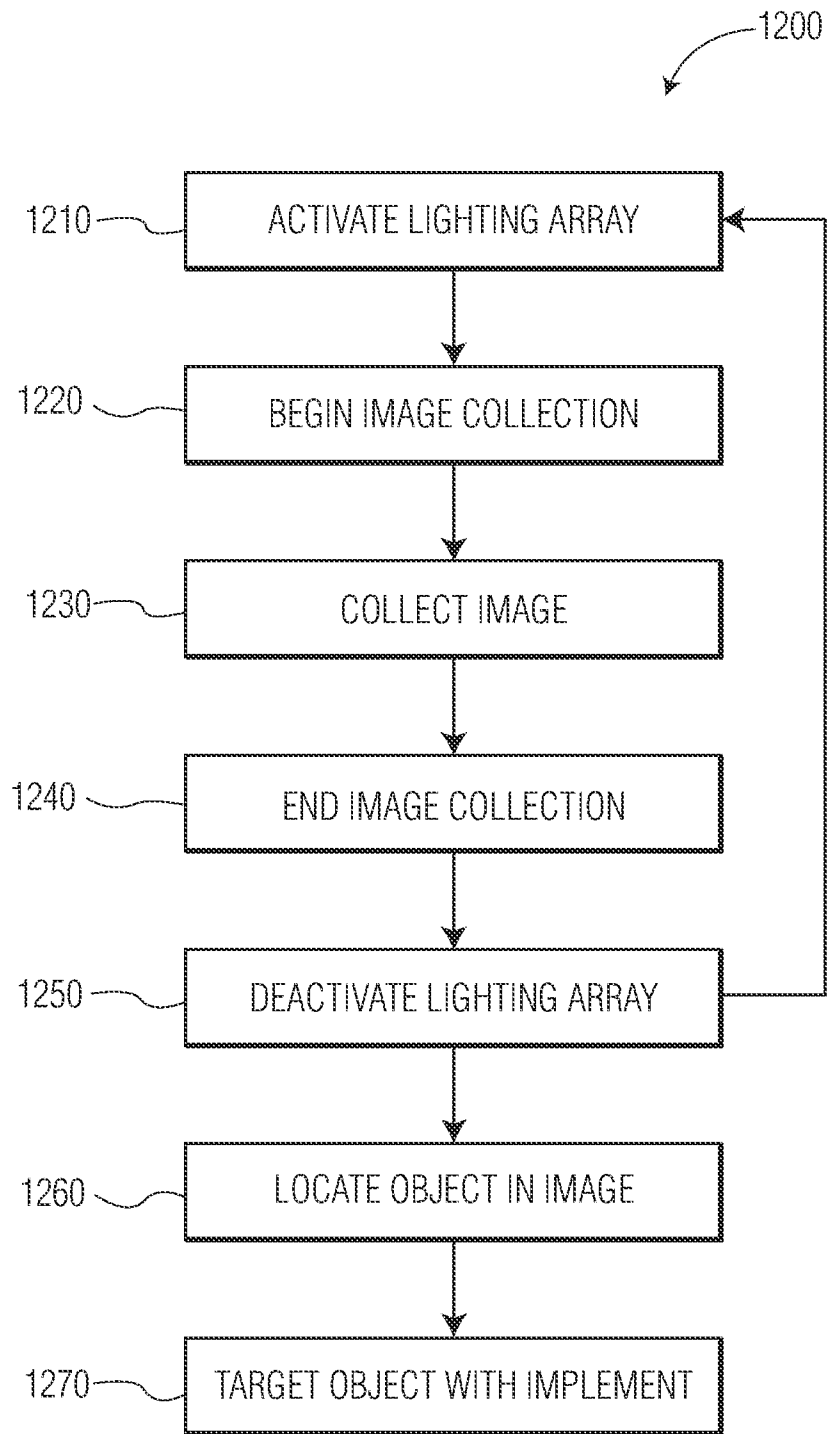

FIG. 12

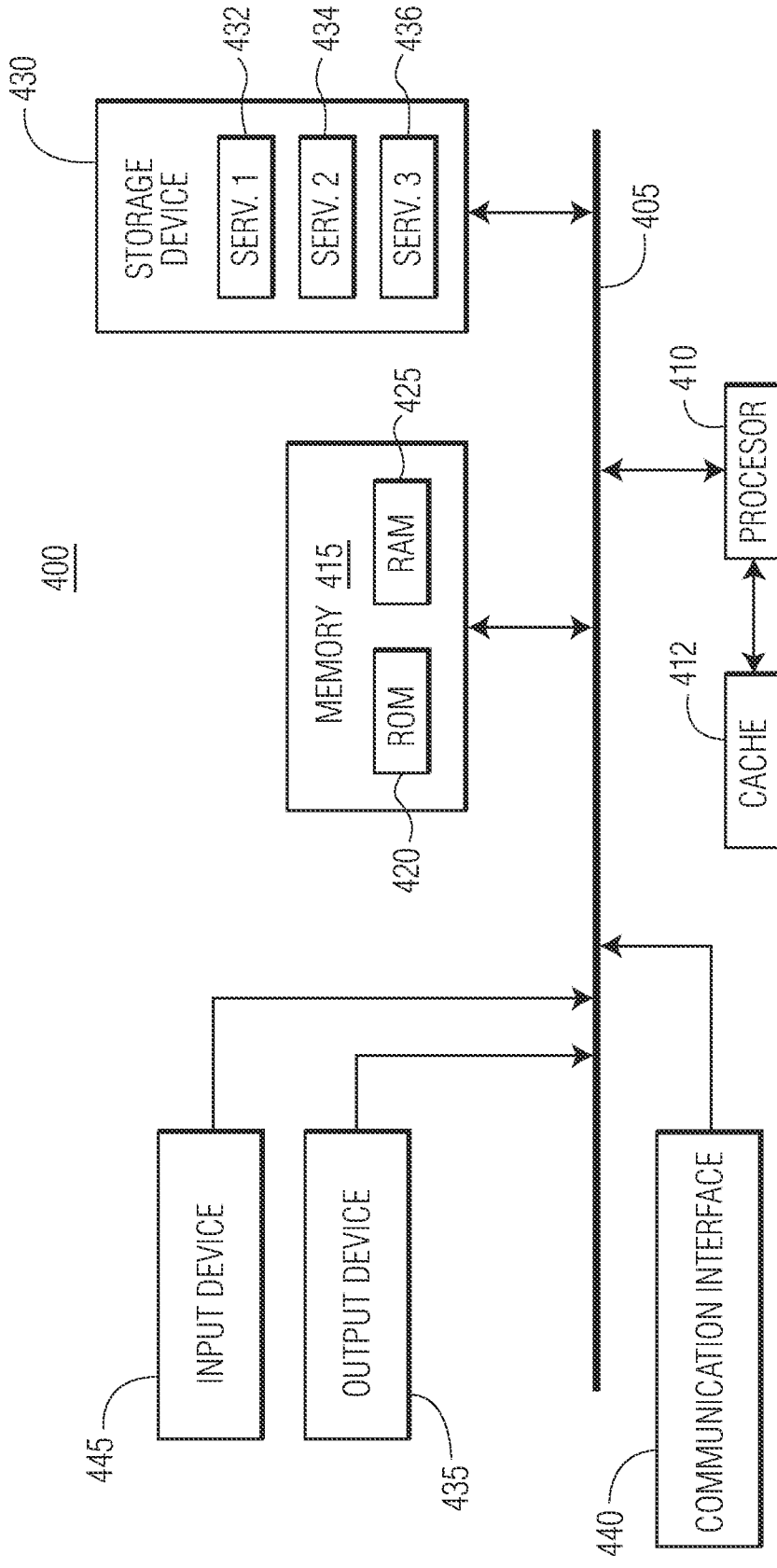

FIG. 13A

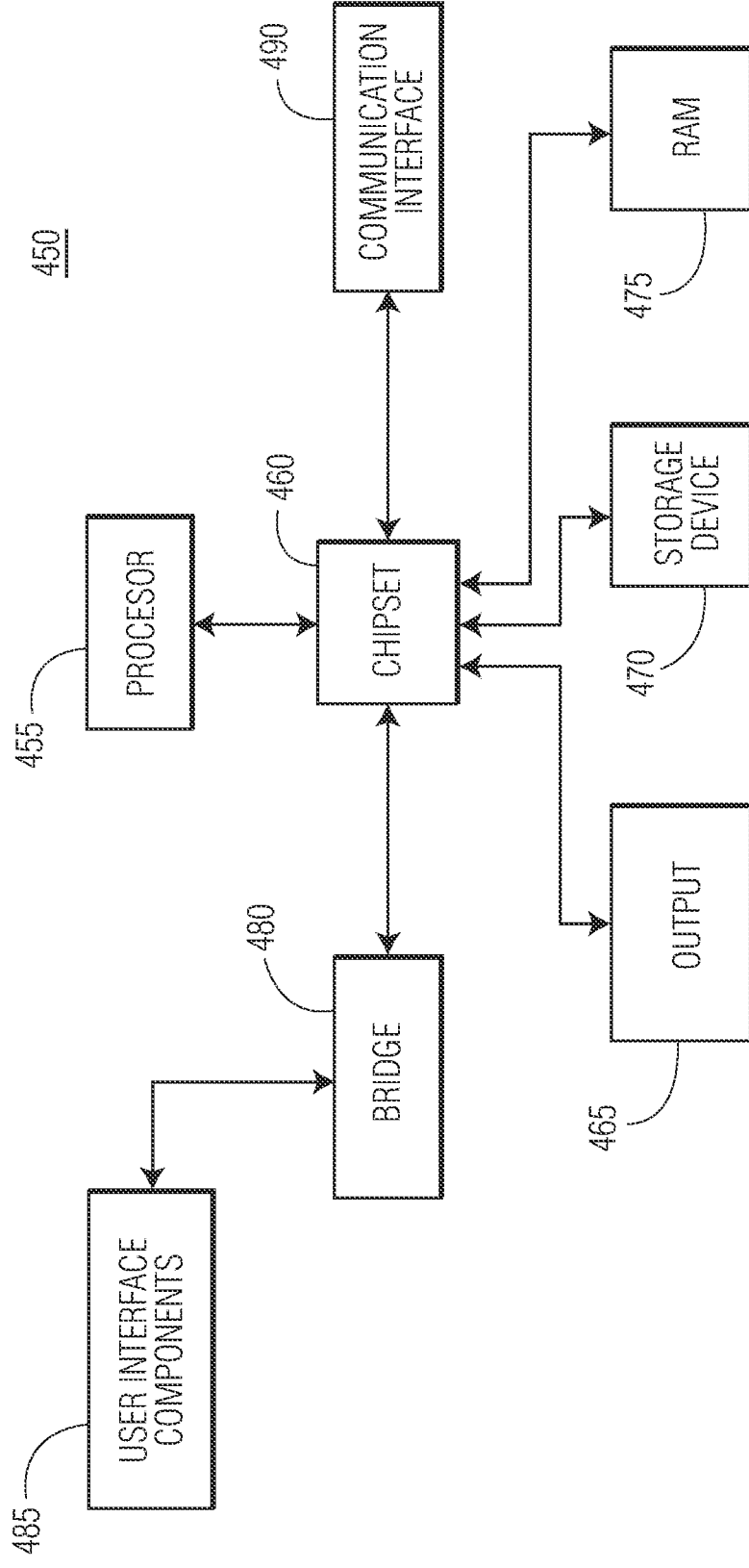

FIG. 13B